

LG-501H

HYDRAULIC SERIES



Features

- LG-501H hydraulic pop up series is designed with hydraulic open and close system.
- Designed for perfect integration into the office Furniture.
- Soft opening with comfort and safety.
- The product is made up of steel and aluminium.
- Product Weight : 2.0 Kg
- Shipping Weight : 2.4 Kg
- Shipping Dimension : 260x210x300 mm (LxWxH)
- Colour available : Black

Connectivity

- 1 x Universal Power
- 1 x USB Charger
- 1 x RJ45 Network
- 1 x VGA
- 1 x 3.5mm Audio
- 1 x HDMI 2.0v

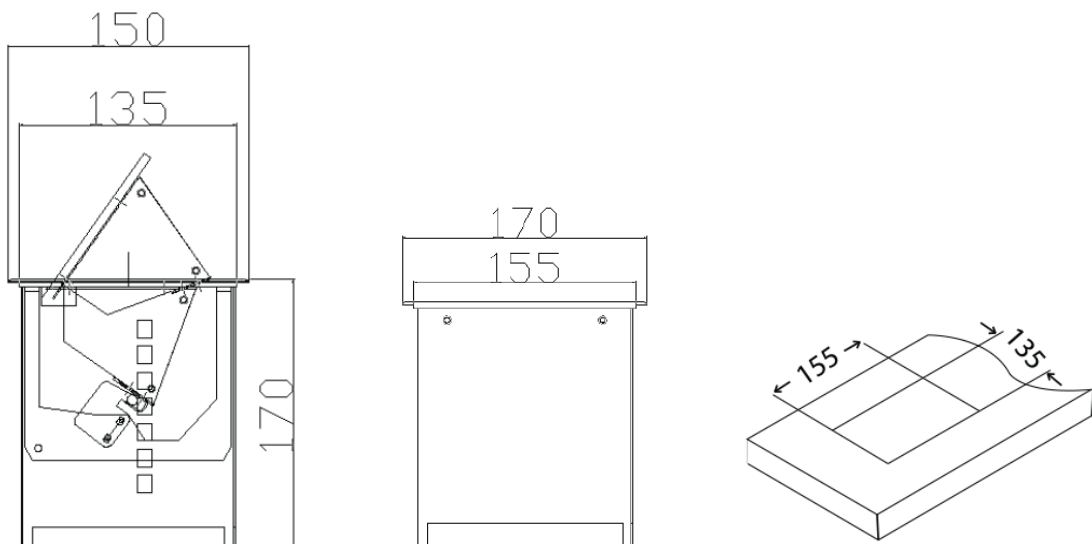

*Dimensions in mm