

LM-305WC-N19

MANUAL SERIES



Features

- LM-305WC-N19 is a compact cable manager solution designed for installation into a table as part of a presentation system.
- The product can be mounted into a table and podium to provide a way to connect audio visual equipments.
- Soft opening with comfort and safety.
- Equipped with slide open cover system.
- The product is made up of steel and aluminium.
- Product Weight : 1.5 Kg
- Shipping Weight : 1.8 Kg
- Shipping Dimension : 180x180x200 mm (LxWxH)
- Colour available : Black

Connectivity

- 1 x Universal Power
- 1 x Wireless Charger
- 1 x RJ45 Network
- 1 x VGA
- 1 x 3.5mm Audio
- 1 x HDMI 2.0v

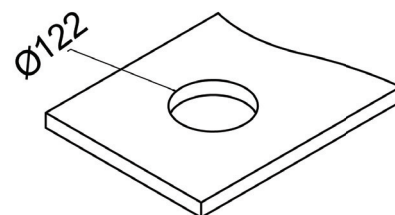
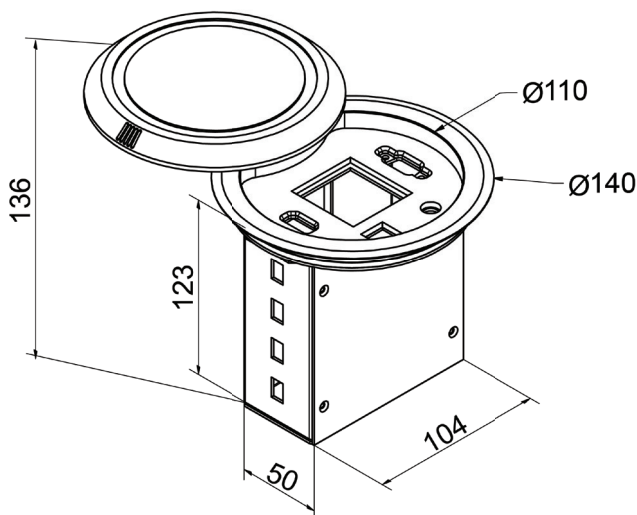

*Dimensions in mm