



Poly Documentation

Copyright © 2024, Plantronics, Inc. All rights reserved. No part of this document may be reproduced, translated into another language or format, or transmitted in any form or by any means, electronic or mechanical, for any purpose, without the express written permission of Polycom, Inc
6001 America Center Drive

San Jose, CA 95002

USA

Contents

1. Poly Studio G62 with VideoOS 4.3.0 Integrator Guide.	5
Legal information.	6
About this guide.	6
About this guide.	7
Audience, purpose, and required skills.	7
Icons used in Poly documentation.	8
Getting Started.	8
Poly Studio G62 product overview.	9
Poly Studio G62 system ports.	9
Poly Studio G62 LED behavior.	11
Powering the System On and Off.	12
Connecting IP peripherals to the Poly Studio G62 LLN port.	13
Supported peripherals on the Poly Studio G62 system.	14
Updating software on components connected to your system.	17
Third-party peripheral compatibility.	17
Connecting modular room IP devices to Poly Studio G62.	18
Poly Studio G62 example configurations.	21
Room Layout Recommendations.	30
Recommended Room Dimensions.	30
Codec Placement.	31
Camera Placement.	32
Microphone Placement.	40
LAN Ports and Power Outlet Placement.	43
Setting up the Poly Studio G62 system.	44
Complete the out of box setup and choose a provider.	44
Connecting and Configuring Cameras on Poly Studio G62.	45
Connecting cameras to Poly Studio G62.	45
Configure General Camera Settings.	55
Connecting and Configuring Audio Peripherals on Poly Studio G62.	63
Connecting audio devices to Poly Studio G62.	63
Configuring audio settings.	71
Connect monitors to the Poly Studio G62 system.	80

Configure Monitor Settings.	81
Connect a third monitor to a system in Zoom Rooms mode.	83
Pairing Controllers to Poly Studio G62.	84
Pair a Poly TC10 or Poly TC8 to your Poly Studio G62 system.	84
Connecting a room scheduler.	85
Content Sharing and Device Mode on Poly Studio G62.	85
Connect a computer to the system.	85
Connect an HDMI content source to your Poly Studio G62.	86
Cable Requirements for Connecting Peripherals to Poly Studio G62.	87
Cable requirements for network connectivity.	87
Cable requirements for camera and monitor connectivity.	88
Cable requirements for audio connectivity.	88
Specifications for Poly Studio G62 and Peripherals.	89
Poly Studio G62 specifications.	90
Poly Studio E60 specifications.	90
Poly Studio E70 specifications.	92
Poly EagleEye IV USB specifications.	93
Working with Poly Studio G62 command-line APIs.	94
Enable SSH access.	95
Access the command-line API over SSH.	95
Enable telnet access.	95
Access the command-line API over telnet.	95
Command-line API reference for Poly Video Mode.	96
About the command-line API.	96
Audio APIs.	100
Calendar APIs.	108
Calling APIs.	124
Camera APIs.	144
Directory and contacts APIs.	152
Content sharing APIs.	180
General APIs.	186
Network APIs.	210
Provisioning APIs.	266
Security APIs.	274
Security APIs.	276
System control and remote control APIs.	278

System settings APIs.	284
Video display APIs.	308
Getting help.	317
HP Inc. addresses.	317
Document information.	317

Poly Studio G62 with VideoOS 4.3.0 Integrator Guide

This guide provides installers and integrators with instructions on how to install and configure the featured product.

- [Legal information](#)

- [About this guide](#)

This section provides clarifying information about this guide.

- [About this guide](#)

This guide provides setup and installation information for the Poly Studio G62 video conferencing system to connect and configure cameras, monitors, controllers, and audio devices. Use this guide to plan and prepare your video conferencing room and integrate your Poly Studio G62 system.

- [Getting Started](#)

Poly Studio G62 enables you to set up a medium to large-size video conferencing room with flexibility and options depending on the number of occupants and type of conference room.

- [Supported peripherals on the Poly Studio G62 system](#)

The Poly Studio G62 system supports the following video and audio peripherals.

- [Room Layout Recommendations](#)

Following the requirements, recommendations, and considerations in this section provides the best meeting experience for meeting participants.

- [Setting up the Poly Studio G62 system](#)

After connecting the peripherals, you can power on and set up your system.

- [Connecting and Configuring Cameras on Poly Studio G62](#)

The following sections describe how to connect cameras to the Poly Studio G62 system.

- [Connecting and Configuring Audio Peripherals on Poly Studio G62](#)

You can connect Poly Studio G62 to multiple types of audio input and output devices.

- [Connect monitors to the Poly Studio G62 system](#)

Connect two 4K monitors to the system to display far-side video and content.

- [Pairing Controllers to Poly Studio G62](#)

Depending on the provider you choose, you can connect one or more supported system controllers.

- [Content Sharing and Device Mode on Poly Studio G62](#)

Use the Poly Studio G62 USB-C port or the HDMI in port to share content.

- [Cable Requirements for Connecting Peripherals to Poly Studio G62](#)

- [Specifications for Poly Studio G62 and Peripherals](#)

Review the product specifications for cable, power, and product dimensions.

- [Working with Poly Studio G62 command-line APIs](#)

The command-line API lets you externally configure and control a Poly Studio G62 system. You can access the API with the following connections:

- [Command-line API reference for Poly Video Mode](#)

The system command-line API is organized by category.

- [Getting help](#)

Poly is now a part of HP. The joining of Poly and HP paves the way for us to create the hybrid work experiences of the future. Information about Poly products has transitioned from the Poly Support site to the HP Support site.

Legal information

Copyright and license

© 2024, HP Development Company, L.P. The information contained herein is subject to change without notice. The only warranties for HP products and services are set forth in the express warranty statements accompanying such products and services. Nothing herein should be construed as constituting an additional warranty. HP shall not be liable for technical or editorial errors or omissions contained herein.

Trademark credits

All third-party trademarks are the property of their respective owners. Google

Privacy policy

HP complies with applicable data privacy and protection laws and regulations. HP products and services process customer data in a manner consistent with the HP Privacy Policy. Please refer to [HP Privacy Statement](#).

Open source software used in this product

This product contains open source software. You may receive the open source software from HP up to three (3) years after the distribution date of the applicable product or software at a charge not greater than the cost to HP of shipping or distributing the software to you. To receive software information, as well as the open source software code used in this product, contact HP by email at ipgoopensourceinfo@hp.com.

About this guide

This section provides clarifying information about this guide.

Audience, purpose, and required skills

This guide is intended for intermediate and advanced users, who want to learn about peripheral compatibility for Poly Studio G62, Poly G7500, and Poly Studio X systems.

Supported and compatible product definitions

This document doesn't include all Poly or third-party conferencing peripherals. Products not listed in this document are untested and not recommended for use with your system.

This document uses the following definitions to indicate products supported or compatible with VideoOS devices.

- **Supported**—Poly products tested for intraoperability with the designated Poly systems and supported by Poly.
- **Not supported**—Poly products that aren't intraoperable with the designated system.
- **Compatible**—Third-party products tested with the designated Poly systems and are interoperable with your deployment. However, these products aren't manufactured or serviced by Poly, so if you experience issues with third-party products, contact the manufacturer for assistance.
- **Not compatible**—Third-party products that Poly tests and aren't interoperable with the designated system.

About this guide

This guide provides setup and installation information for the Poly Studio G62 video conferencing system to connect and configure cameras, monitors, controllers, and audio devices. Use this guide to plan and prepare your video conferencing room and integrate your Poly Studio G62 system.

- [Audience, purpose, and required skills](#)

This guide is for system integrators who need to configure, customize, manage, and troubleshoot Poly Studio G62 video conferencing systems in medium- to large-sized conference rooms.

- [Icons used in Poly documentation](#)

This section describes the icons used in Poly documentation and what they mean.

Audience, purpose, and required skills

This guide is for system integrators who need to configure, customize, manage, and troubleshoot Poly Studio G62 video conferencing systems in medium- to large-sized conference rooms.

You must be familiar with the following concepts before beginning:

- Current telecommunications practices, protocols, and principles.
- Telecommunication basics, video conferencing, and voice or data equipment.
- Knowledge and experience with audio/video (A/V) cable installation and management.

Icons used in Poly documentation

This section describes the icons used in Poly documentation and what they mean.

Note	Indicates a hazardous situation that, if not avoided, could result in serious injury or death.
Note	Indicates a hazardous situation that, if not avoided, could result in minor or moderate injury.
Note	Indicates information considered important but not hazard-related (for example, messages related to property damage). Warns the user that failure to follow a procedure exactly as described could result in loss of data or in damage to hardware or software. Also contains essential information to explain a concept or to complete a task.
Note	Contains additional information to emphasize or supplement important points of the main text.
Note	Provides helpful hints for completing a task.

Getting Started

Poly Studio G62 enables you to set up a medium to large-size video conferencing room with flexibility and options depending on the number of occupants and type of conference room.

Poly Studio G62 supports Poly Video mode and multiple partner application modes. For supported partner applications, see the *Poly VideoOS Release Notes*.

- [Poly Studio G62 product overview](#)
The Poly Studio G62 system is a modular video conferencing system with HDMI, link-local network (LLN), and USB connections to support custom conference rooms.
- [Poly Studio G62 system ports](#)
The following diagram describes the ports available on a Poly Studio G62 system.
- [Poly Studio G62 LED behavior](#)
Use the LED on the front left corner of the Poly Studio G62 system to get information on the state of your system.
- [Powering the System On and Off](#)
The system powers on when you plug it in to a power source.
- [Connecting IP peripherals to the Poly Studio G62 LLN port](#)
Connect Poly IP microphones and Poly IP cameras to your Poly Studio G62 system link-local network (LLN) port.

Poly Studio G62 product overview

The Poly Studio G62 system is a modular video conferencing system with HDMI, link-local network (LLN), and USB connections to support custom conference rooms.

Poly Studio G62 is designed with simplified mounting and PoE+ class 4 power, so you can place it behind a display, under a table, or in an A/V rack. The Poly Studio G62 system supports Poly audio and video products over IP LLN as well as Poly and third-party products using the USB and 3.5 mm system ports.

The Poly Studio G62 system brings the following functionality to your conferencing space:

- Audio innovations such as NoiseBlockAI including Sound Reflection Reduction
- DirectorAI camera framing and tracking
- Configurable second network port for accessories
- Dual monitor 4K video
- Flexible installation with cable management
- USB-C DP Alt Mode port for content and device mode
- Wireless content sharing using Airplay or Miracast

Poly Studio G62 system ports

The following diagram describes the ports available on a Poly Studio G62 system.

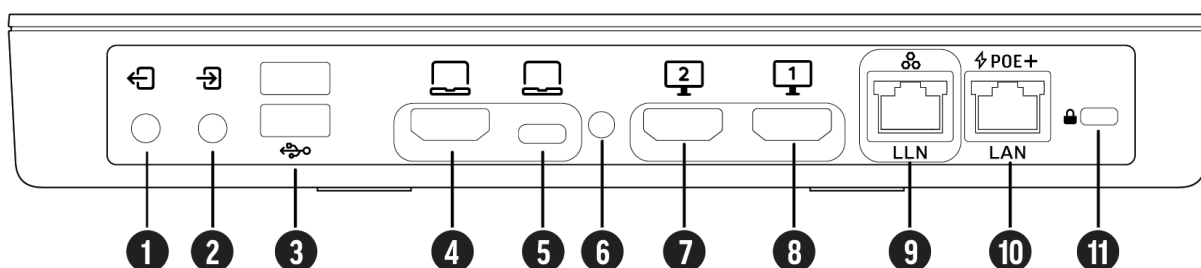

Table 1. Poly Studio G62 Ports

Item	Port	Description
1	3.5 mm output	Connects speakers to the system.
2	3.5 mm input	Connects microphones to the system.
3	USB Type-A ports (3.0)	Connects USB cameras or USB audio DSPs.
4	HDMI input	<p>Provides the following options:</p> <ul style="list-style-type: none"> ● Connects an HDMI content source or HDMI camera. ● Use the system monitor when connected to a computer HDMI port. <p>Provides content sharing capabilities.</p>
5	USB Type-C port	<p>Provides the following options:</p> <ul style="list-style-type: none"> ● Use the system camera, speaker, and microphone from a connected laptop. ● Use the system camera, speaker, microphone, and monitor using a DP Alt-mode connection. Requires a supported DP Alt-mode cable and a computer with a USB Type-C port that supports DP Alt-mode.

Item	Port	Description
6	Pinhole reset	Factory resets the system.
7	HDMI 2	Connects a secondary monitor.
8	HDMI 1	Connects a primary monitor.
9	LLN port	Connects IP peripherals such as a Poly IP microphone or Poly IP camera. This port doesn't provide power. A PoE switch or PoE injector is required to power IP peripherals connected to the LLN port.
10	PoE+ power input	Powers the Poly Studio G62 system using a class 4 PoE+ injector or PoE+ switch. Provides access to the corporate network.
11	Security lock	Physically secures the system.

Poly Studio G62 LED behavior

Use the LED on the front left corner of the Poly Studio G62 system to get information on the state of your system.



Table 1. Poly Studio G62 LED Behavior

Indicator	Status
Blinking white	Powering on
Solid white	Powered on
Solid green	In a call
Blinking amber	Update in progress
Solid amber	Sleeping
Blinking red	Error preventing normal operations
Solid red	Muted microphone

Powering the System On and Off

The system powers on when you plug it in to a power source.

Poly recommends the following when powering off or restarting your system:

- Don't restart or power off the system during maintenance activities (for example, while a software update is in progress).
- If a system restart is necessary, use the system web interface, RestAPI, Telnet, or SSH. If possible, avoid removing power to restart the system.
- [Power on your Poly Studio G62 system](#)
You can use a PoE+ class 4 injector or a PoE+ class 4 Ethernet connection to power your system.

Power on your Poly Studio G62 system

You can use a PoE+ class 4 injector or a PoE+ class 4 Ethernet connection to power your system.

The Poly Studio G62 system doesn't include a power button. The system powers on when connected to a PoE+ class 4 injector or Ethernet switch. If your PoE connection doesn't provide sufficient power, the system LED changes to blinking red, and the following message displays on the monitor:

"Insufficient Power from System Ethernet Port"

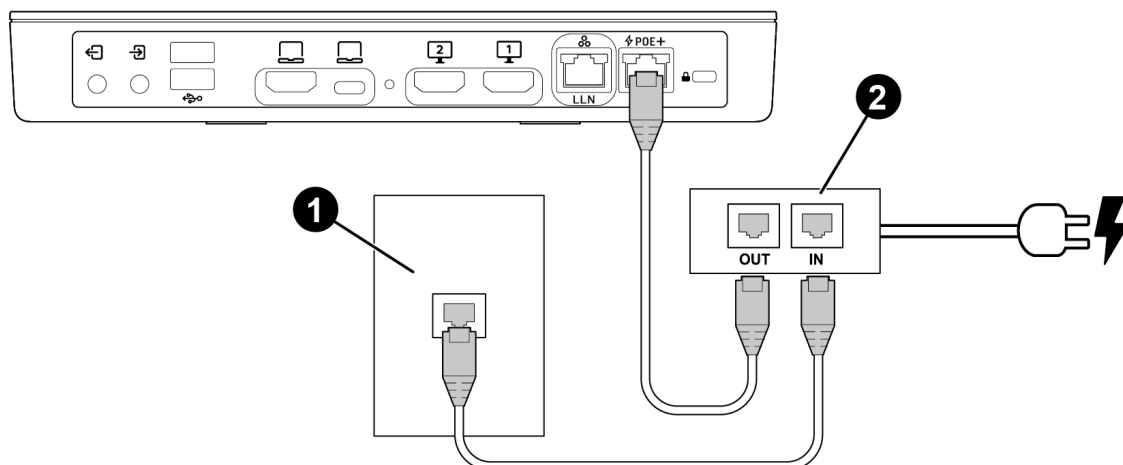

Table 1. Components for powering on a Poly Studio G62

Item	Description
1	Ethernet connection to the corporate network.
2	PoE+ class 4 power injector.

Procedure

- 1 Connect the PoE+ LAN port on the Poly Studio G62 system to the Out port on the PoE+ class 4 power injector.
- 2 Connect the In port on the PoE+ class 4 power injector to a network Ethernet port.

Alternatively, you can connect the Poly Studio G62 system directly to a PoE+ class 4 Ethernet port or Ethernet switch.

Connecting IP peripherals to the Poly Studio G62 LLN port

Connect Poly IP microphones and Poly IP cameras to your Poly Studio G62 system link-local network (LLN) port.

Note For supported peripherals and configurations, see the *Poly VideoOS Release Notes*.

When connecting IP devices to the Poly Studio G62 system LLN port, observe the following:

- The Poly Studio G62 system LLN port provides a secure connection for audio and video IP devices such as Poly IP microphones and a Poly Studio E70 camera.
The Poly Studio G62 LLN port doesn't provide power to connected peripherals.
- To power multiple IP peripherals connected to the Poly Studio G62 system LLN port, use a supported A/V Ethernet switch such as a Netgear A/V Line M4250 GSM4210PD.
If you're connecting one IP peripheral, you can use a PoE injector rated for the peripheral you're connecting.
- The LLN port doesn't provide network access.
Don't connect IP devices that require network access to the LLN port. Devices that require network access include Poly TC10, Poly TC8, and Poly Trio C60.
- To connect IP peripherals, use a CAT5e, CAT6, or CAT7 direct STP Ethernet cable. The cable can be up to 91 m (300 ft) in length.

Supported peripherals on the Poly Studio G62 system

- [Updating software on components connected to your system](#)
While you can connect a variety of components to your system, only certain components can be updated while connected to the system.
- [Third-party peripheral compatibility](#)
Poly tests Poly Studio G62 system with a variety of standards-based peripherals.
- [Connecting modular room IP devices to Poly Studio G62](#)
Connect modular room peripherals to the LLN port on Poly Studio G62 systems using a link-local network (LLN) switch.
- [Poly Studio G62 example configurations](#)

The Poly Studio G62 system supports the following video and audio peripherals.

Note Poly Studio G62 ships with Poly VideoOS 4.1.5. Update your system to Poly VideoOS 4.3.0, at minimum, as part of setting up your system. Poly VideoOS 4.3.0 For information on enhancements and fixes included in Poly VideoOS 4.3.0, see the [Poly VideoOS Release Notes](#).

Table 1. Supported cameras and video bars on Poly Studio G62 systems

Peripheral	Poly Video Mode	Device Mode	Microsoft Teams Rooms	Zoom Rooms
Poly Studio E70 camera (USB) (Supports connecting up to two)	Supported	Supported	Supported	Supported
Poly Studio E70 camera (IP LLN)	Supported (Supports connecting up to three)	Supported (Supports connecting up to three)	Supported (Supports connecting one)	Supported (Supports connecting up to three)
Poly Studio E60 camera (USB) (Supports connecting up to two)	Supported	Supported	Supported	Supported
Poly EagleEye IV USB camera (Supports connecting up to two)	Supported	Supported	Supported	Supported

Table 2. Supported audio peripherals on Poly Studio G62 systems

Peripheral	Poly Video Mode	Device Mode	Microsoft Teams Rooms	Zoom Rooms
Poly IP Ceiling Microphone (up to three IP microphones supported)	Supported	Supported	Supported	Supported
Poly IP Table Microphone (up to three IP microphones supported)	Supported	Supported	Supported	Supported
Poly Trio C60 (up to four supported)	Supported	Supported	Poly Trio C60 (one supported) (audio only)	Supported
Biamp DSP USB audio processors	Compatible	Compatible	Compatible	Supported
QSC Core Series audio processors	Compatible	Compatible	Compatible	Supported
Shure IntelliMix P300 audio conferencing processor*	Compatible	Compatible	Compatible	Supported

*The Shure Intellimix P300 is a Microsoft Certified peripheral.

Table 3. Supported controllers on Poly Studio G62 systems

Peripheral	Poly Video Mode	Device Mode	Microsoft Teams Rooms	Zoom Rooms
Poly TC10 touch controller	Supported	Supported	Supported	Supported
Poly TC8 touch controller	Supported	Supported	Supported	Supported
G7500 Bluetooth remote	Supported	Supported	Not Supported	Not Supported
IR Remote	Supported	Supported	Not Supported	Not Supported
Touch Display	Supported	Supported	Supported	Supported

Updating software on components connected to your system

While you can connect a variety of components to your system, only certain components can be updated while connected to the system.

Software and firmware for the following products are included in the VideoOS software package. All other peripherals connected to your system must be updated independently. For more information on updating peripherals not listed below, see the user or administrator guide for the product.

- Poly IP microphones
 - Poly Studio E70 camera
 - Poly Studio E60 camera
 - Poly TC10 and Poly TC8 touch controllers
- Poly TC10 and Poly TC8 must have access to the Poly update server to receive updates.

Third-party peripheral compatibility

Poly tests Poly Studio G62 system with a variety of standards-based peripherals.

Note If you connect an unsupported camera, the system still attempts to show video. Poly can't guarantee that the results are optimal or that the available settings are the same as a supported camera.

If you use a third party peripheral with your Poly Studio G62 system, issues with the device should be directed to the device manufacturer.

Connecting modular room IP devices to Poly Studio G62

Connect modular room peripherals to the LLN port on Poly Studio G62 systems using a link-local network (LLN) switch.

Poly Studio G62 systems support connecting modular room IP cameras and microphones using the system LLN port. Use the supported Netgear ProAV M4250-9G1F-PoE+ (GSM4210PD) switch to connect up to six IP devices.

At this time, Poly modular room IP peripherals include the Poly Studio E70 camera, Poly IP table microphones, and Poly IP ceiling microphones.

When connecting IP peripherals to Poly Studio G62 systems, note the following:

- Poly systems don't support mixing USB and IP connection types.
- Poly Studio G62 systems support only the Netgear ProAV M4250-9G1F-PoE+ (GSM4210PD) switch for connecting multiple IP peripherals to the LLN port. Configure the switch using the instructions provided by Poly. Poly doesn't support other switches or configurations. Using an unsupported switch or configuration may cause audio and content issues.
If you're connecting only one IP peripheral to the Poly Studio G62 LLN port, you can use a PoE injector rated for the IP device you're connecting.
- On the Poly touch controller, camera controls for the Poly Studio E70 camera aren't available when connected via IP. Use the system web interface to change tracking modes.

Modular room IP device support by provider

Table 1. Modular room IP devices per provider

Provider	Supported Poly Studio G62 connections
Microsoft Teams Rooms	One Poly Studio E70 camera and three Poly IP microphones
Zoom Rooms	Three Poly Studio E70 cameras and three Poly IP microphones

Provider	Supported Poly Studio G62 connections
Poly Video	Three Poly Studio E70 cameras and three Poly IP microphones

- [Configure the network switch](#)
Manually configure your modular room network switch to ensure a stable experience with Poly modular room peripherals.
- [Connect modular room IP peripherals to the Poly Studio G62 LLN port using a network switch](#)
Connect Poly modular room peripherals to a Poly Studio G62 system using a supported network switch to ensure a stable experience.

Configure the network switch

Manually configure your modular room network switch to ensure a stable experience with Poly modular room peripherals.

Make sure you have the following equipment:

- Laptop with an Ethernet port
- Ethernet patch cable
- Netgear ProAV M4250-9G1F-PoE+ (GSM4210PD) network switch

Note Automatic network switch configuration isn't supported in this release.

Procedure

- 1 On your computer, go to <https://lens.poly.com>.
- 2 Sign in to Poly Lens Cloud and go to **Manage > Software Versions**.
- 3 Search for **Modular Room Switch**.
- 4 Download the file to your computer and unzip the file contents.
- 5 Turn on the network switch and connect the Ethernet patch cable to your laptop and the port labeled OOB on the back of the switch.
- 6 Configure the following settings for your computer's Ethernet interface:
 - Static IP address: 192.168.0.200
 - Subnet mask: 255.255.255.0

- Leave the default gateway blank
- 7 Open a Command Prompt (Windows) or Terminal (Mac) and create a continuous ping to 192.168.0.239.
 - Windows: `ping 192.168.0.239 -t`
 - Mac: `ping 192.168.0.239`
 - 8 When the ping replies start responding, open a web browser and go to <http://192.168.0.239>.

The ping replies may take up to three minutes.
 - 9 Under **Login**, enter `admin`.
 - 10 When prompted, set the password to `PoLy!4567`.
 - 11 Select **AV UI Login**.
 - 12 On the left sidebar, select **Configure > Maintenance > Firmware Update**.
 - 13 Browse to the location of your extracted files, select the file named `M4250L-v13.0.4.19.stk` and select **Upload**.

After a few minutes, a dialog appears stating that the upload was successful.
 - 14 Select **Reboot Now**.

Allow four minutes for this process to complete.
 - 15 Refresh the web browser, and select **OK** on the dialog stating that the account login timed out.
 - 16 Sign in using your credentials, and select **AV UI Login**.
 - 17 Select **Maintenance** under the **Configuration** section.
 - 18 In the **Configuration Management** section, select **Browse file** and click in the blank space.

A file web browser opens.
 - 19 Browse to the downloaded files, and select the file labeled `PoLy-MR-16.cfg` and select **Upload**.
 - 20 Once the progress bar turns green and reaches one hundred percent, select **Restore Now**.
 - 21 On the top-right corner of the page, select **Reboot**.
 - 22 When prompted to save the configuration settings, select **No**.

Allow four minutes for this process to complete.
 - 23 Refresh the web browser, and select **OK** on the dialog stating that the account login timed out.
 - 24 Sign in using your credentials, and select **AV UI Login**.
 - 25 Go to **Device Details** and verify that the firmware version is 13.0.4.19.
 - 26 Under **Configured Profiles**, verify that there's a Poly profile beginning with Poly-MR.
 - 27 Once complete, you can close the web browser and disconnect the Ethernet cable connected to your computer and the switch.

Connect modular room IP peripherals to the Poly Studio G62 LLN port using a network switch

Connect Poly modular room peripherals to a Poly Studio G62 system using a supported network switch to ensure a stable experience.

Procedure

- 1 Connect the Ethernet patch cable to port 9 on the Netgear ProAV M4250-9G1F-PoE+ (GSM4210PD) switch.
- 2 Connect the cable to the left RJ-45 port (labeled **LLN**) on the back of the Poly Studio G62 system.
- 3 Connect your Poly modular room peripherals as needed to ports 1 to 8 on the switch.

Poly Studio G62 example configurations

The following are some sample configurations and cabling diagrams that you can use for setting up your Poly Studio G62 system.

Table 1. Medium Room Configuration with Poly Studio E70 and Poly Studio Trio C60

Room Size	Camera	Microphone	Speakers	Monitors	Controllers
Medium	Poly Studio E70 camera (USB)	1x Poly Trio C60	1x Poly Trio C60	2	Poly TC10 room controller
Medium	Poly Studio E70 (IP)	2x Poly IP table microphone	JBL Pro Soundbar	2	Poly TC10 room controller
Medium/ Large	Poly Studio E60 camera (USB)	2x Poly IP table microphone	JBL Pro SoundBar	2	Poly TC10 room controller
Large (Zoom Rooms)	Poly Studio E70 x 3 (IP)	Poly IP table microphones x3	3.5 mm audio DSP	3	Poly TC10 room controllers

Medium room configuration with Poly Studio E70 and Poly Trio C60

The following configuration is supported in Poly Video, Poly Device Mode, and Zoom Rooms mode.

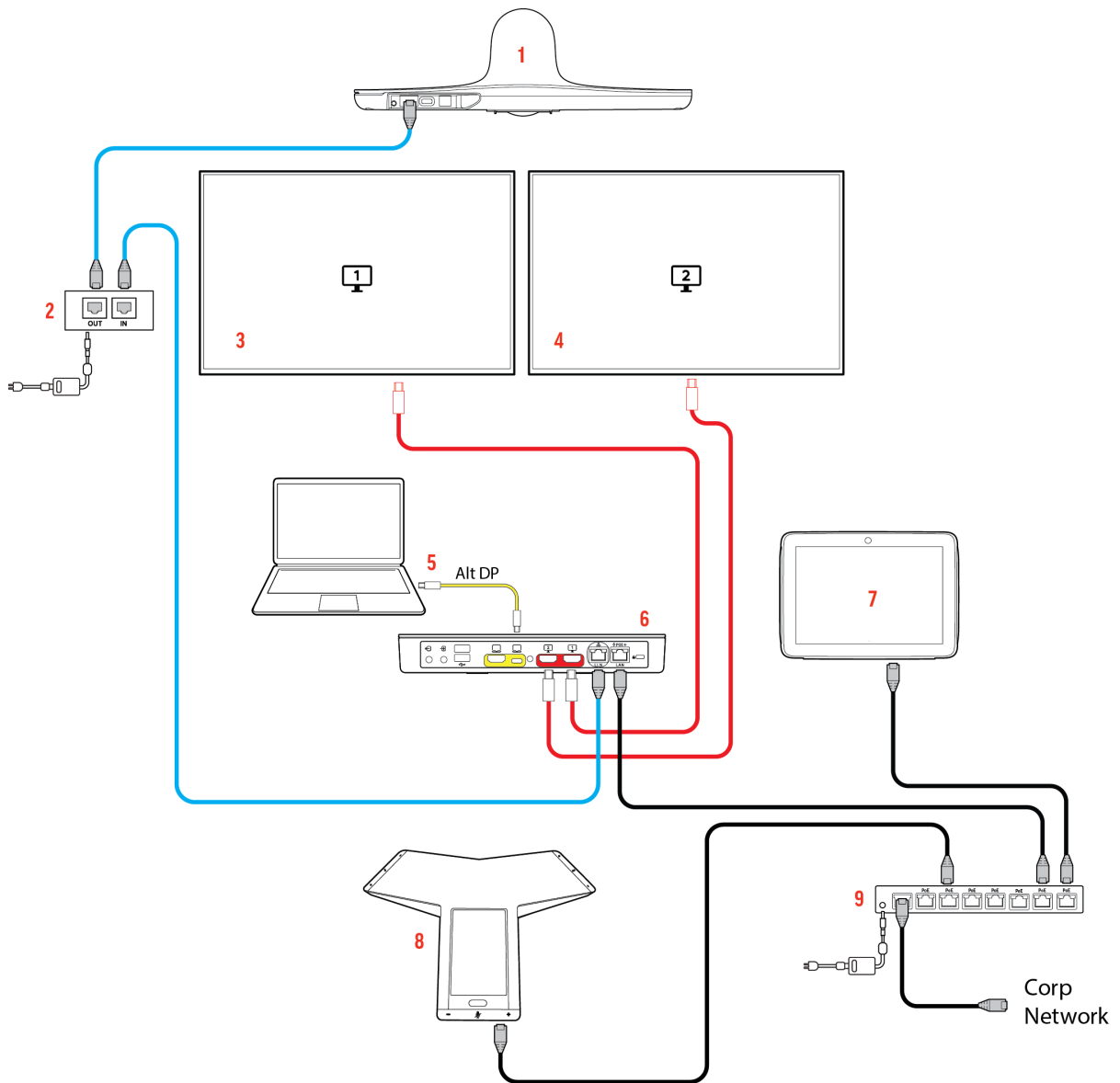

Table 2. Medium room configuration with Poly Studio E70 and Poly Trio C60 components

Item	Description	Connection
1	Poly Studio E70 camera	Connect an Ethernet cable from the PoE injector to the LLN port on the Poly Studio G62.
2	PoE injector	Connect an Ethernet cable from the Poly Studio G62 LLN port to the In port on the PoE injector. Connect the Out port of the PoE injector to the Poly Studio E70 camera.
3	Monitor 1	Connect an HDMI cable from HDMI 1 on monitor 1 to HDMI 1 on the Poly Studio G62.
4	Monitor 2	Connect an HDMI cable from HDMI 1 on monitor 2 to HDMI 2 on the Poly Studio G62.
5	Laptop (Device Mode)	Alt DP USB-C port from the laptop using the supported Alt DP USB cable to connect to the Poly Studio G62.
6	Poly Studio G62 system	Connect to a PoE+ class 4 power Ethernet switch, Ethernet port, or PoE injector. Connect the Ethernet switch or PoE injector to the network.
7	Poly TC10 touch controller	Connect an Ethernet cable from the Poly TC10 to a PoE Ethernet switch connected to the network.
8	Poly Trio C60	Connect an Ethernet cable from the Poly Trio C60 to a PoE Ethernet switch connected to the network.
9	Ethernet switch with PoE+ class 4 power	Connect an Ethernet cable from the Ethernet switch to the network.

Medium/Large room configuration with Poly Studio E60 camera

The following configurations supported in Poly Video, Poly Device Mode, Teams Rooms, and Zoom Rooms modes.

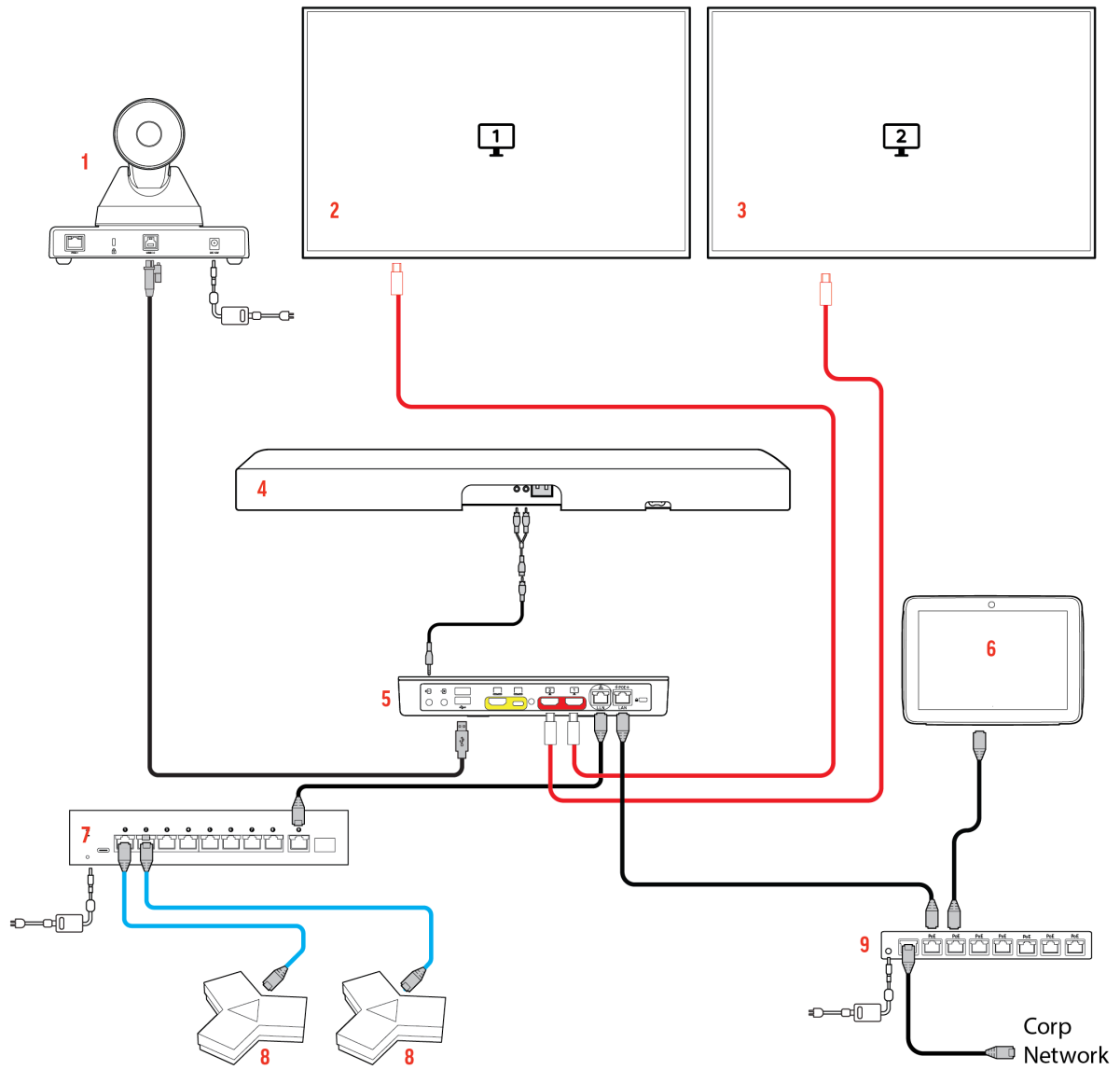

Table 3. Medium/Large room configuration with Poly Studio E60 camera components

Item	Description	Connection
1	Poly Studio E60 camera	Use the USB Type-B to USB Type-A cable that shipped with the system and connect to a USB Type-A port on the Poly Studio G62.
2	Monitor 1	Connect an HDMI cable from HDMI 1 on monitor 1 to HDMI 1 on the Poly Studio G62.
3	Monitor 2	Connect an HDMI cable from HDMI 1 on monitor 2 to HDMI 2 on the Poly Studio G62.
4	JBL Pro SoundBar PSB-1	Connect the red and white RCA connection to the 3.5 mm adapter that ships with the soundbar. Connect the 3.5 mm cable to the Poly Studio G62 line out.
5	Poly Studio G62 system	Connect to an Ethernet switch with PoE+ class 4 power connected to the network.
6	Poly TC10 touch controller	Connect an Ethernet cable from the Poly TC10 to a PoE Ethernet port connected to the network.
7	Netgear A/V Line M4250 GSM4210PD Ethernet switch.	Connect an Ethernet cable from the Ethernet switch to the LLN port on the Poly Studio G62. Configure the Netgear switch per the instructions in this guide.
8	Poly IP Table microphones	Connect an Ethernet cable from the IP microphones to the PoE Ethernet switch connected to the Poly Studio G62 LLN port.
9	Ethernet switch with PoE+ class 4 power	Connect an Ethernet cable from the Ethernet switch to the network.

Medium/Large room configuration with Poly Studio E70 camera

The following configurations supported in Poly Video, Poly Device Mode, Teams Rooms, and Zoom Rooms modes.

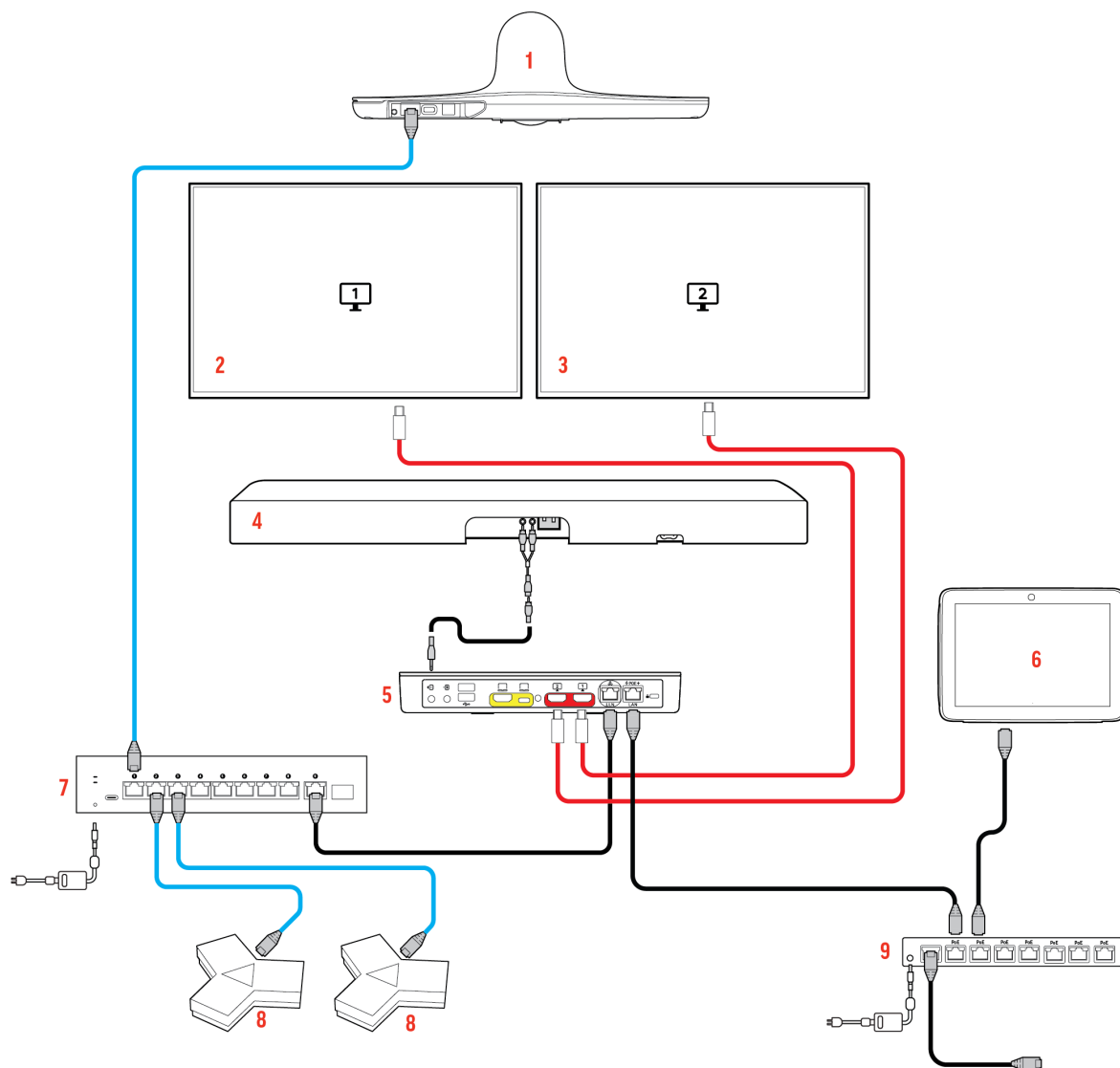

Table 4. Medium/Large room configuration with Poly Studio E70 camera components

Item	Description	Connection
1	Poly Studio E70 camera	Connect an Ethernet cable from Poly Studio E70 to the PoE Ethernet switch connected to the Poly Studio G62 LLN port.
2	Monitor 1	Connect an HDMI cable from HDMI 1 on monitor 1 to HDMI 1 on the Poly Studio G62.
3	Monitor 2	Connect an HDMI cable from HDMI 1 on monitor 2 to HDMI 2 on the Poly Studio G62.
4	JBL Pro SoundBar PSB-1	Connect the red and white RCA connection to the 3.5 mm adapter that ships with the soundbar. Connect the 3.5 mm cable to the Poly Studio G62 line out.
5	Poly Studio G62 system	Connect to an Ethernet switch with PoE+ class 4 power connected to the network.
6	Poly TC10 touch controller	Connect an Ethernet cable from the Poly TC10 to a PoE Ethernet port connected to the network.
7	Netgear A/V Line M4250 GSM4210PD Ethernet switch.	Connect an Ethernet cable from the Ethernet switch to the LLN port on the Poly Studio G62. Configure the Netgear switch per the instructions in this guide.
8	Poly IP Table microphones	Connect an Ethernet cable from the IP microphones to the PoE Ethernet switch connected to the Poly Studio G62 LLN port.
9	Ethernet switch with PoE+ class 4 power	Connect an Ethernet cable from the Ethernet switch to the network.

Large room configuration with Poly Studio E70 and Poly IP table microphones for Zoom Rooms

Connecting a third monitor to the system is supported in Zoom Rooms only.

Poly Video and Zoom Rooms support connecting up to three Poly Studio E70 cameras to the Poly Studio G62 using a Netgear A/V Line M4250-9G1F-PoE+ (GSM4210PD) Ethernet switch. The switch must be configured per Poly instructions.

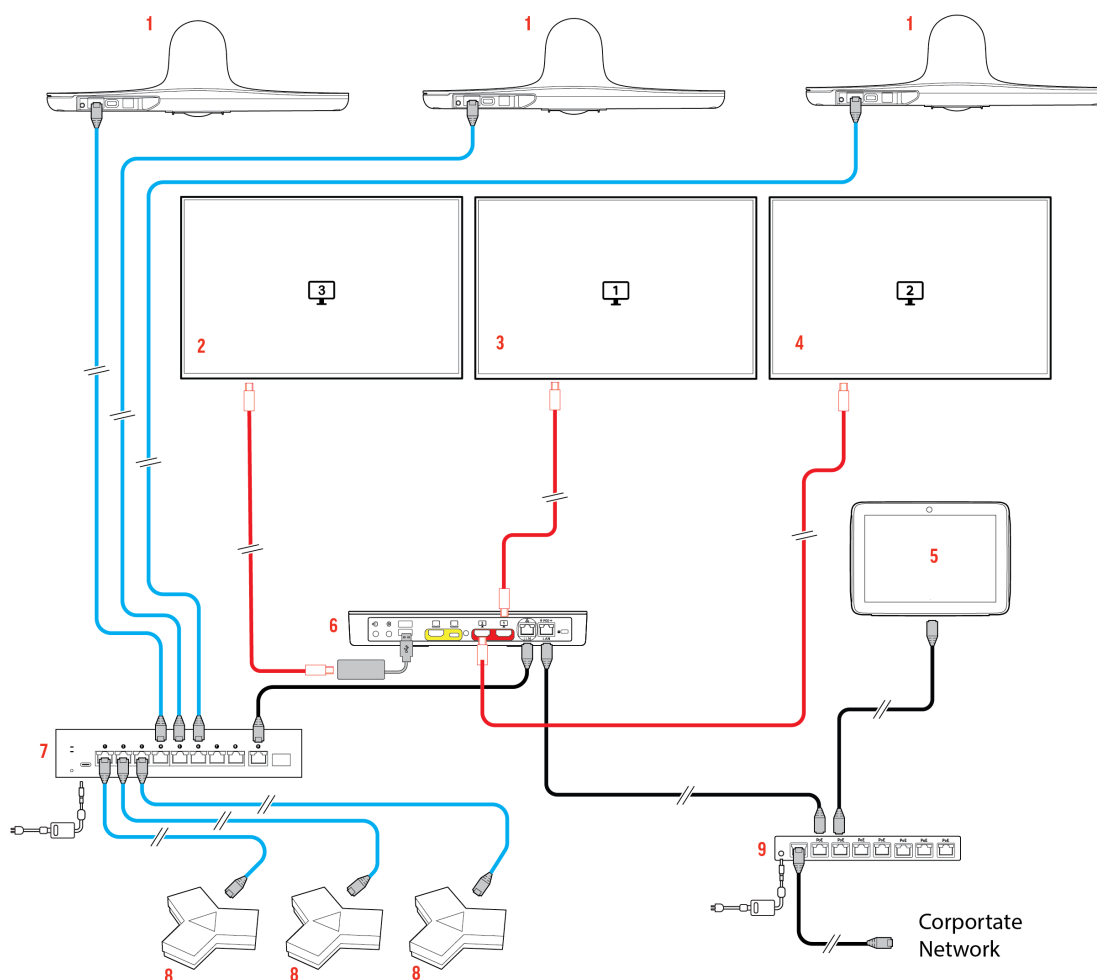

Table 5. Medium/Large room configuration with Poly Studio E60 camera components

Item	Description	Connection
1	Poly Studio E70 camera((x3)	Connect an Ethernet cable from Poly Studio E70 to the PoE Ethernet switch connected to the Poly Studio G62 LLN port.
2	Monitor 3	Connect the Plugable USB to HDMI adapter (UGA-2KHDMI) to a USB-A port on the Poly Studio G62. Connect a HDMI cable from the Plugable adapter to HDMI 1 on monitor 3.
3	Monitor 1	Connect an HDMI cable from HDMI 1 on monitor 1 to HDMI 1 on the Poly Studio G62.
4	Monitor 2	Connect an HDMI cable from HDMI 1 on monitor 2 to HDMI 2 on the Poly Studio G62.
5	Poly TC10 touch controller	Connect an Ethernet cable from the Poly TC10 to a PoE Ethernet port connected to the network.
6	Poly Studio G62 system	Connect to an Ethernet switch with PoE+ class 4 power connected to the network.
7	Netgear A/V Line M4250-9G1F-PoE+ (GSM4210PD) Ethernet switch.	Connect an Ethernet cable from the Ethernet switch to the LLN port on the Poly Studio G62. Configure the Netgear switch per the instructions in this guide.
8	Poly IP Table microphones (x3)	Connect an Ethernet cable from the IP microphones to the PoE Ethernet switch connected to the Poly Studio G62 LLN port.
9	Ethernet switch with PoE+ class 4 power	Connect an Ethernet cable from the Ethernet switch to the network. Connect the Poly TC10 Poly Studio G62 to the Ethernet switch.

Room Layout Recommendations

Following the requirements, recommendations, and considerations in this section provides the best meeting experience for meeting participants.

Consider the following information before the installation visit for your Poly Studio G62 video conferencing system:

- Recommended room dimensions
- Codec placement
- System characteristics and cable lengths
- LAN ports and power outlet placement
- Camera placement
- Microphone placement
- Display options

- [Recommended Room Dimensions](#)

Poly recommends using the appropriate video conferencing system based on your conferencing room size. Using a video conferencing system in a room that is too large, for example, might lead to cut off audio or a decrease in video quality.
- [Codec Placement](#)

The location of your codec depends on several factors, and correct placement ensures a great conferencing experience.
- [Camera Placement](#)

When planning the placement of your cameras, think about room size, monitor location, camera type and other options to ensure you provide the optimum viewing experience for the far-side.
- [Microphone Placement](#)

The ideal location for microphones in a conference environment is near the speaker. When speakers see the microphone while in a seated position relative to the video screen and within the distance guidelines presented in this document, the room microphone detects their voices more clearly.
- [LAN Ports and Power Outlet Placement](#)

Planning cable layouts and confirming the number of power outlets you need are important considerations before installing a Poly system.

Recommended Room Dimensions

Poly recommends using the appropriate video conferencing system based on your conferencing room size. Using a video conferencing system in a room that is too large, for example, might lead to cut off audio or a decrease in video quality.

The following table lists recommended room dimensions.

Note Camera distance refers to the recommended maximum distance of the room participant that is furthest from the camera. See [Camera Placement](#) for more information, including example camera framing diagrams.

Table 1. Room Dimensions

Room Size	Recommended Dimensions	Recommended Poly System	Camera Distance
Extra Large	>6 m (19.7 ft) x 10 m (32.8ft)	Poly Studio G62 with Poly Studio E60	> 10 m (32.8 ft)
Large	6 m (19.7 ft) x 10 m (32.8 ft)	Poly Studio G62 with Poly Studio E70 or Poly Studio E60	6.1 m (20 ft)
Medium	4.5 m (14.8 ft) x 6 m (19.7 ft)	Poly Studio G62 with Poly Studio E70	4.6 m (15 ft)

Codec Placement

The location of your codec depends on several factors, and correct placement ensures a great conferencing experience.

Measure your space before installation and plan the codec placement.

Procedure

- 1 Place the codec within the standard cable lengths to ensure that cables reach the required equipment. You might need additional cables or connectors if you place equipment outside of the standard cable lengths.

Note If you need to extend the length of cables between your system components, Poly recommends working with your A/V integrator or partner. They can help you implement certified solutions that work with the unique requirements in your environment.

- 2 Place your codec in an area that provides ventilation around the codec. Poly recommends a minimum distance of 35 mm (1.3 inches) on each side of the codec. Covering the ventilation opening can result in overheating and system instability.

Note Review the important safeguards for your system mentioned in the Safety and Regulatory Notices located at the Poly Online Support Center.

Camera Placement

When planning the placement of your cameras, think about room size, monitor location, camera type and other options to ensure you provide the optimum viewing experience for the far-side.

Camera types

Use the camera that is best suited to your conference room size. Choose from the following options:

- Connect one or two Poly Studio E60 or Poly Studio E70 cameras to the two Poly Studio G62 USB Type-A ports.
- Connect a Poly Studio E70, powered using a PoE or an optional Poly Studio E70 power adapter, to the Poly Studio G62 LLN port.
The Poly Studio G62 LLN port doesn't provide power to connected peripherals.

Monitor and Camera Position

Consider the following monitor placement and camera mounting tips:

- Mount the monitor so that the center of the display is at eye level with seated participants, approximately 1.07 m (42 in.) from the finished floor. Then position the camera as close to that level as possible.
- When placing your camera on the monitor, choose locations that are near to the center lines (vertical and horizontal) of the display showing the far-side speakers. This location lends itself to a natural sense of eye contact.
- Don't point your camera at a busy background. This includes busy patterns or interior and exterior windows that have a lot of traffic.
- Centering a camera between multiple displays may be aesthetically pleasing, but it can compromise eye contact.
- The parallax error appears less pronounced as the distance between the camera and the subject increases. Participants in a large conference room with offset cameras may be able to view eye contact as normal, but huddle or focus rooms may be too small for the camera distance to compensate for the perceived error.
- Don't mount cameras at extreme heights and then point them down like surveillance cameras. Mounting cameras at extreme heights may cause eye contact issues and skew the images of people. Detections may also become a problem.
- A practical maximum height is 1.8 m to 2.1 m (6 ft to 7 ft) from the floor to the center line of the camera housing (the lower camera lens).

See [Recommended Room Dimensions](#) for recommended maximum camera distances when setting up your system.

- [Camera Placement on Monitors](#)

The position and elevation of the monitor in a meeting room often determines whether you mount the camera above or below the display.

- **Field of View**

Make sure your camera uses a wide enough field of view (FOV) that covers the participants located furthest from the camera.

- **Camera Auto-Framing**

Poly camera framing technology can automatically frame groups of people and follow conversations in meeting rooms.

Camera Placement on Monitors

The position and elevation of the monitor in a meeting room often determines whether you mount the camera above or below the display.

Ideally, position the monitor so that the center of the display is at eye level of seated participants, approximately 1.07 m (42 in.) from the finished floor. Then mount the camera as close to that level as possible—this is usually on top of the monitor.

In some circumstances however, the monitor may have to be at an elevated position relative to the audience, meaning you must mount the camera in an inverted setup below the monitor to meet the recommended participant eye line positioning.

The following diagram shows a participant sitting in a room with the camera mounted below the monitor, instead of the recommended position of near the center lines of the display. Since the participant must look up at the display to see the relevant conference information, the far side receives a view of the participant looking away from and much higher than the camera view.

Note The camera placement guidance presented in this guide might not apply to special applications and environments.

Figure 1. Camera mounted below monitor

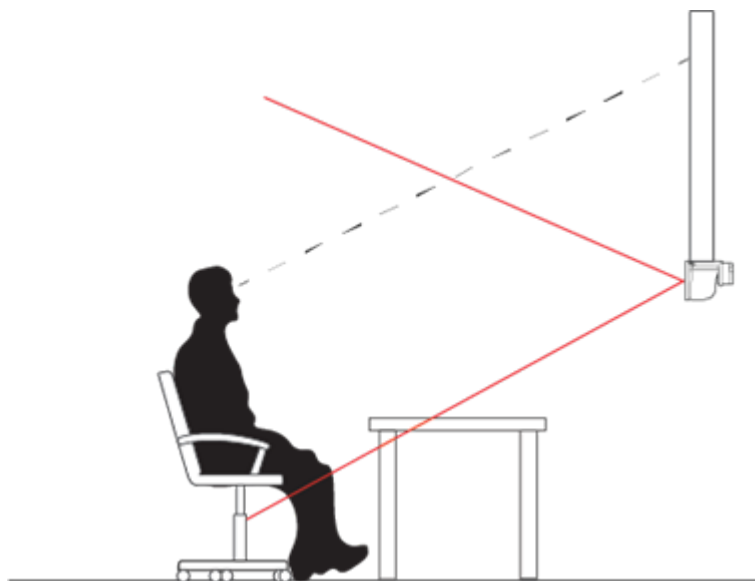

Note the following:

- Placing cameras outside an ideal location can have negative results. For example, positioning a camera below a monitor can render an unintentional and possibly unflattering perspective to the far-side viewers if a meeting attendee walks in front of the camera.
- Positioning cameras too far outside the center lines of the display can also create a parallax error. This parallax error results in the person on camera appearing to look away from the speaker even though the person on camera is actually looking at the speaker. A significant loss of eye contact can cause a sense of inattention or mistrust, so avoiding those appearances is important.

Field of View

Make sure your camera uses a wide enough field of view (FOV) that covers the participants located furthest from the camera.

For example, a Poly Studio G62 system with a Studio E70 camera is ideal for a large room configuration because the camera specifications offer both a wide field of view: 120-degree horizontal field of view (HFOV) and a narrower 70-degree HFOV, with 7.62 m (25 ft) maximum user distance.

- [Poly Studio E70 Field of View](#)

The Poly Studio E70 camera has an articulating hinge located at the bottom of its base. You can manipulate this hinge to rotate the camera from side to side or to tilt it up and down to an angle that provides a wide enough field of view for your conference. For best results, Poly recommends that you position the camera so that its centerline points to the person seated furthest from the camera.

- [Poly Studio E60 Field of View](#)

The Poly Studio E60 camera is a mechanical PTZ camera capable of 10 m (32.8 ft) with a vertical field of view (VFOV) of 43 degrees and a horizontal field of view (HFOV) of 71 degrees.

Poly Studio E70 Field of View

The Poly Studio E70 camera has an articulating hinge located at the bottom of its base. You can manipulate this hinge to rotate the camera from side to side or to tilt it up and down to an angle that provides a wide enough field of view for your conference. For best results, Poly recommends that you position the camera so that its centerline points to the person seated furthest from the camera.

The following diagrams show the range of the Poly Studio E70 camera's narrow vertical field of view (VFOV) (11 degrees) and wide VFOV (49 degrees) when you position the camera at level and forward tilt positions, and the room participant furthest from the camera is at various distances.

Note The Poly Studio E70 electronics don't allow pan or tilt when the camera is at full-wide angle. You must zoom in to allow pan or tilt.

Poly Studio E70 in a moderate tilt position

The following diagram shows the perspective of the Poly Studio E70 camera when the room participant at the furthest distance from the camera is 1.83 m (6 ft) away. At this distance, moderately tilting the camera forward captures the room participant in the camera's narrow and wide VFOV.

Figure 1. Poly Studio E70 in a moderate tilt position

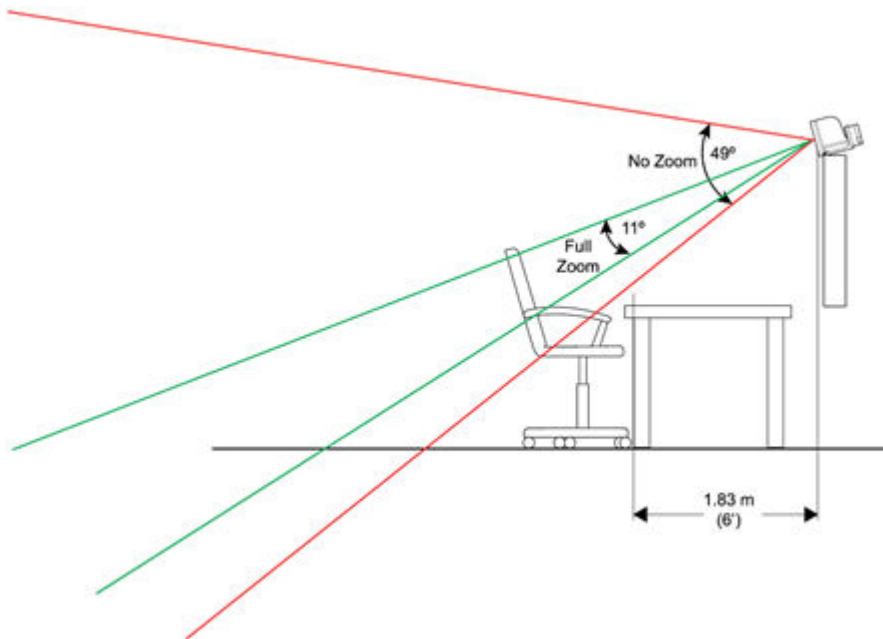

Poly Studio E70 in a modest tilt position

The following diagram shows the perspective of the Poly Studio E70 camera when the room participant at the furthest distance from the camera is 3.66 m (12 ft) away. At this distance, slightly tilting the camera forward captures the room participant in the camera's narrow and wide VFOV.

Figure 2. Poly Studio E70 in a modest tilt position

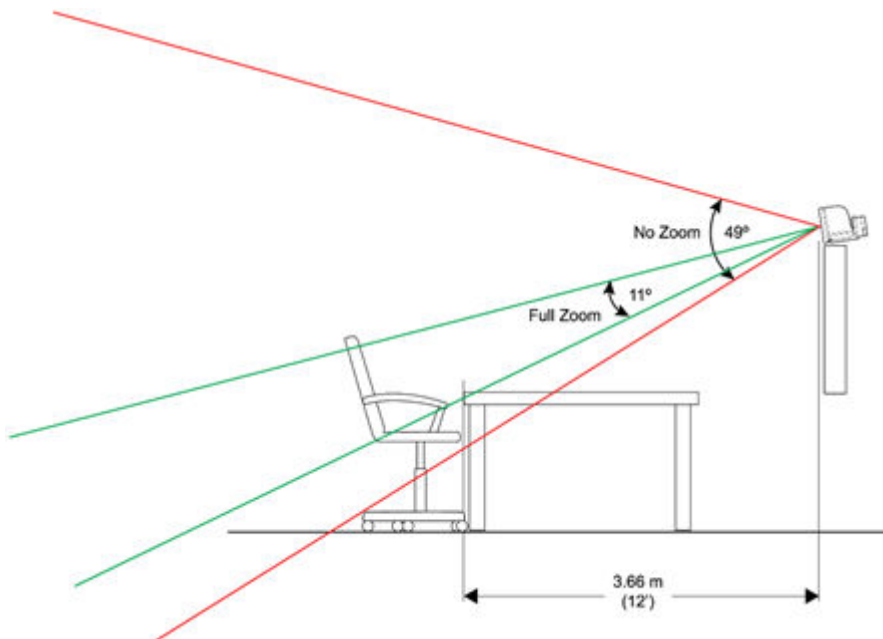

Poly Studio E70 in a level position

The following diagram shows the perspective of the Poly Studio E70 camera when the room participant at the furthest distance from the camera is 7.62 m (25 ft) away. At this distance, placing the camera at a level position captures the room participant in the camera's narrow and wide VFOV.

Figure 3. Poly Studio E70 in a level position

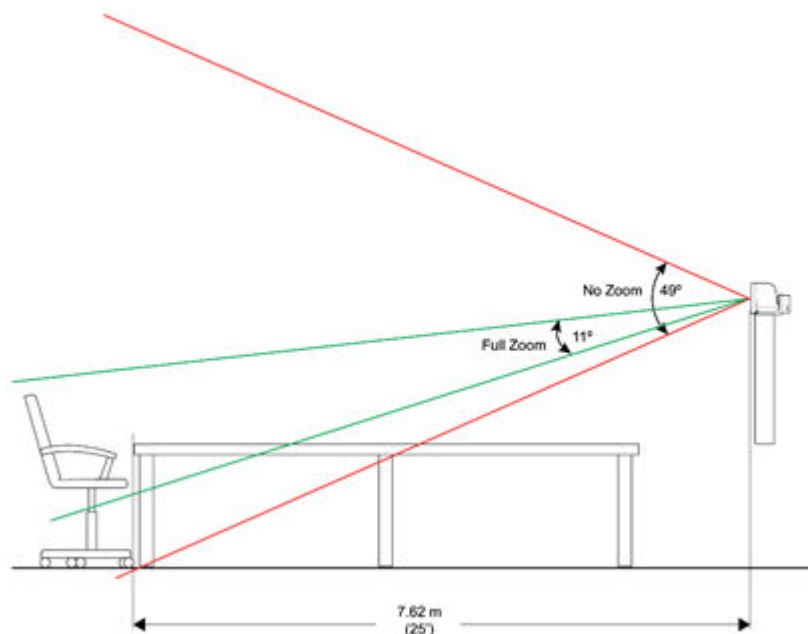

Poly Studio E70 with Poly DirectorAI Perimeter Configured

The Poly Studio E70 camera uses all visible range to track meeting participants. With a glass conference room it's possible for anyone standing outside the room to be identified as a participant.

In this situation, with a glass conference room, Poly recommends DirectorAI Perimeter, which allows you to define the area in which the camera tracks meeting participants. With DirectorAI Perimeter, you can designate the area used by the camera for camera tracking. In the following diagram, Poly DirectorAI Perimeter isolated the area around the conference table.

Figure 4. Poly Studio E70 with Poly DirectorAI Perimeter Configured

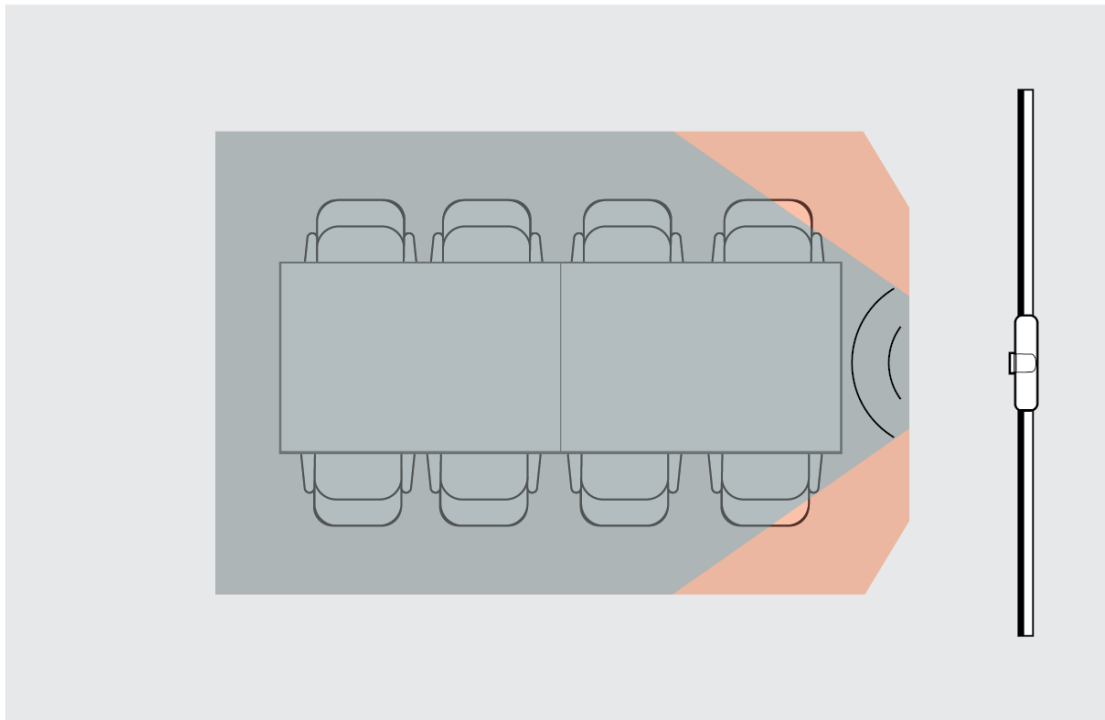

Poly Studio E60 Field of View

The Poly Studio E60 camera is a mechanical PTZ camera capable of 10 m (32.8 ft) with a vertical field of view (VFOV) of 43 degrees and a horizontal field of view (HFOV) of 71 degrees.

With a mechanical PTZ camera, the camera can pan and tilt to capture all parts of the room. However, due to the HFOV, the camera is best suited for a medium to large room with the first seat at least 1 meter (3.3 feet) from the front of room monitor.

For best results, Poly recommends that you position the camera so that its center line, in the initial position, points to the person seated furthest from the camera.

Figure 1. Poly Studio E60 VFOV 6 feet to 18 feet

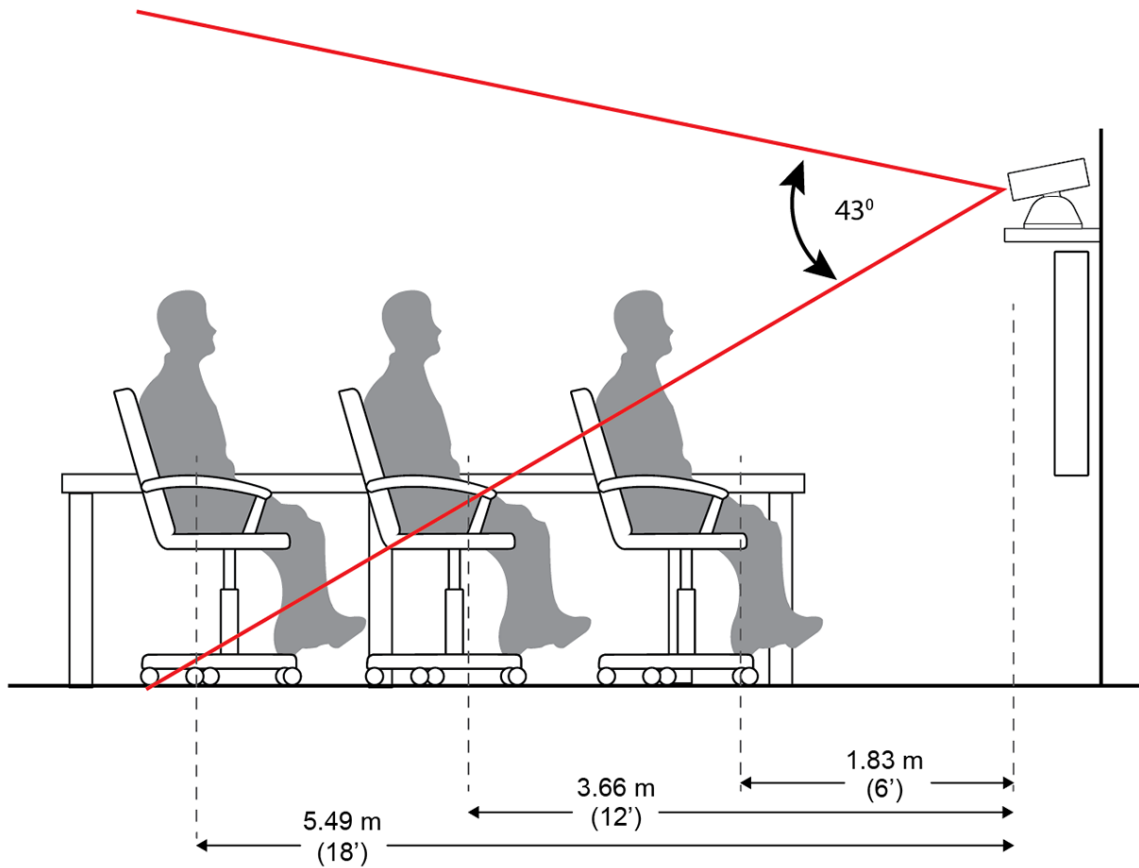
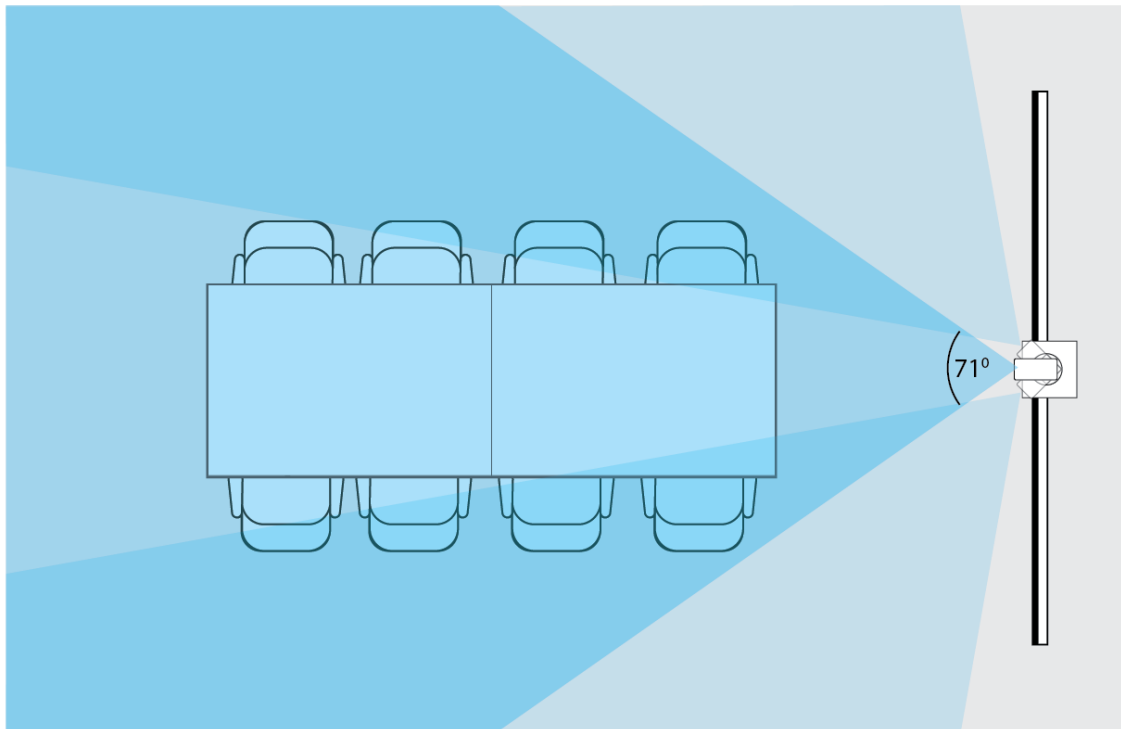

Figure 2. Poly Studio E60 HFOV with the first seat approximately 1 m (3.3 ft.) feet from the camera



Camera Auto-Framing

Poly camera framing technology can automatically frame groups of people and follow conversations in meeting rooms.

Position the cameras in the room to provide optimal framing performance. Framing options and behavior depend on your connected camera.

Consider the following tips for obtaining optimal camera framing performance:

- Keep the camera FOV free of distractions. Avoid having an open doorway, glass wall to a corridor, or a window in the background of the meeting participants.
- Maintain a consistent color temperature of room lighting including any contribution by outside windows.
- Don't place items in the camera's FOV that can distract the camera's system performance. Examples are human-like figures or statues on the meeting table or human facial images on the wall. The camera may detect these and decide to focus on them.
- Refer to a camera's distance specifications to avoid detection failures.

See your conferencing application's support documentation for details on supported cameras, multicamera support, certification, and camera switching support.

Microphone Placement

The ideal location for microphones in a conference environment is near the speaker. When speakers see the microphone while in a seated position relative to the video screen and within the distance guidelines presented in this document, the room microphone detects their voices more clearly.

Consider the following tips for optimal microphone placement:

Note	Sound levels decrease by one-fourth at the microphone as the distance from the speaker doubles, which can quickly cause an unfavorable audio experience.
-------------	--

- Placing microphones with a similar distance between participants helps the far end hear conversations more smoothly and even sounding.
- Direct sound is preferable to reflected sound. Avoid positioning participants with their back to a microphone, which can cause their voices to sound dull and contain significant amounts of room reverberance.
- Position a table microphone closer to the display to enable the microphone to hear meeting participants directly, which improves the fidelity of the audio sent to the far end.
- Multiple microphones are ideal for meetings with rectangular conference tables where people sit along a long edge. Using multiple microphones ensures there's even coverage of each speaker.
- Avoid placing any microphones where direct airflow from fans or HVAC might touch the microphone.
- The minimum distance to place a microphone in relation to a room loudspeaker is 1 m (3 ft).
- [Audio Pickup Ranges](#)
Understanding the audio pickup range for a microphone can also help you determine the most suitable locations for your microphones. Microphone pickup range refers to the distance at which a microphone is sensitive to sound.
- [Poly IP Ceiling microphone placement](#)
Use recommended Poly IP ceiling microphone placement to ensure the best sound quality for far end participants.
- [Poly IP Table microphone placement](#)
Use recommended Poly IP table microphone placement to ensure the best sound quality for far end participants.
- [Example Microphone Placement Layouts](#)
This section includes diagrams of example layouts of Poly IP table microphones and ceiling microphones.

Audio Pickup Ranges

Understanding the audio pickup range for a microphone can also help you determine the most suitable locations for your microphones. Microphone pickup range refers to the distance at which a microphone is sensitive to sound.

The following tables list the typical and maximum audio pickup ranges for the Poly Studio USB and Poly Studio R30 built-in microphones and common microphone solutions. Typical audio pickup ranges refer to acceptable audio quality under most room conditions without causing the far end difficulty in understanding the speech.

Distances that are further than the typical range might be acceptable under conditions with good room acoustics (low reverberance and noise). The maximum audio pickup range value refers to the recommended furthest distance under any room conditions.

Note All distances are subject to the ambient noise and reverberant characteristics of the room in use.

Table 1. Audio Pickup Ranges for Common Microphone Solutions

Microphone Solution	Typical Distance	Maximum Distance
Poly IP table microphone	Circle with a radius of 1 m (3.3 ft) away from the microphone	Circle with a radius of 2.5 m (8.2 ft) away from the microphone
Poly IP ceiling microphone	Circle with a radius of 1.5 m (4.9 ft) directly below the microphone	Circle with a radius of 3.5 m (11.5 ft) directly below the microphone

Poly IP Ceiling microphone placement

Use recommended Poly IP ceiling microphone placement to ensure the best sound quality for far end participants.

Poly recommends placing ceiling microphones above the conference room table and shifted toward the video screen away from a group of people seated at a table.

Poly IP Table microphone placement

Use recommended Poly IP table microphone placement to ensure the best sound quality for far end participants.

The optimal placement for table microphones is about an arm's length away from the speaker and centered between the speaker and the video screen showing the far end image. For small groups,

positioning the microphone in the middle of the table and between the speakers and the video screen is best.

Example Microphone Placement Layouts

This section includes diagrams of example layouts of Poly IP table microphones and ceiling microphones.

The circles in the diagrams represent the audio pickup range for typical (small circle) and maximum (large circle) distances from the system.

Poly IP Table microphone placement

1m (3.3 ft) from the microphone = works under all room conditions

2.5m (8.2 ft) from the microphone = maximum distance under typical room conditions

Table microphones should be placed no closer than 2m apart and no further than 5m apart.

Poly IP Ceiling microphone placement

1.5m (4.92 ft) from the microphone = works under all room conditions

3.5m (11.48 ft) from the microphone = maximum distance under typical room conditions

Poly IP Ceiling mics should be placed no closer than 3m apart and no further than 7m apart.

Example layouts

Figure 1. 1 IP Table or 1 IP Ceiling Microphone Layout

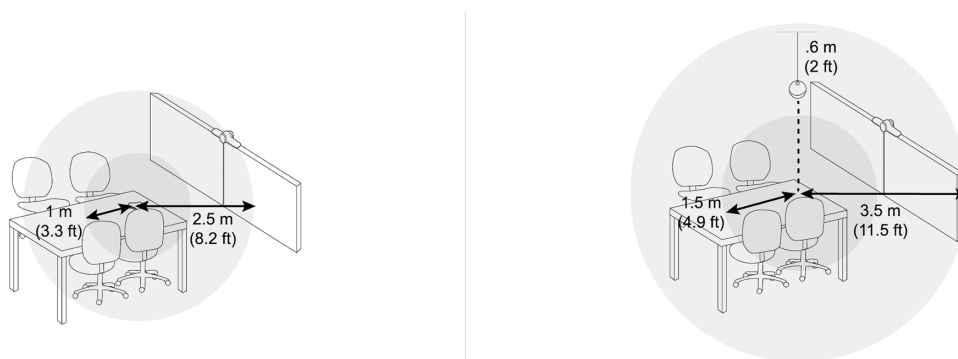

Figure 2. 2 IP Table or 2 IP Ceiling Microphone Layout

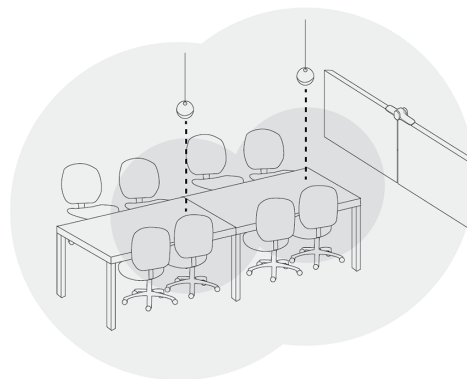
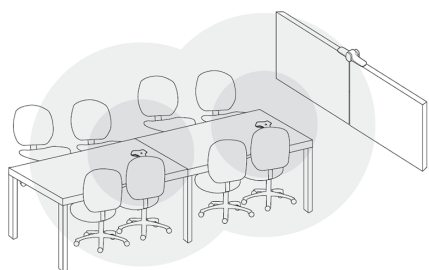
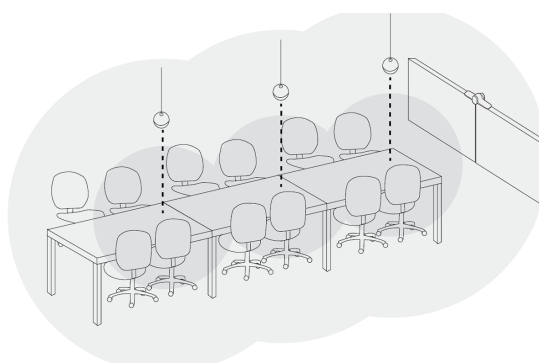
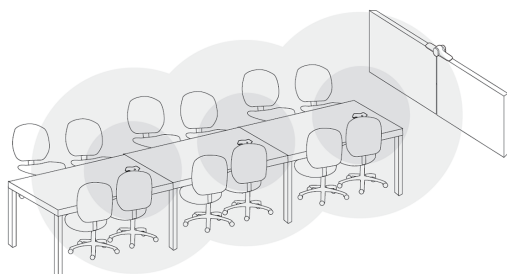

Figure 3. 3 IP Table or 3 IP Ceiling Microphone Layout



LAN Ports and Power Outlet Placement

Planning cable layouts and confirming the number of power outlets you need are important considerations before installing a Poly system.

Consider the following power outlet and cabling tips:

- In most cases, your Poly conferencing solution requires access to multiple Ethernet ports on the same subnet.
If possible, place the teleconferencing system near LAN ports in the wall.
Make sure there are available Ethernet ports near the location of a paired Touch Controller device or Trio phone for the best installation experience.
- Poly recommends running all cables underneath the floor to avoid accidentally tripping or falling. If you can't run cables under the floor, consider using an in-carpet solution or an over-the-floor cable cover.
- Verify that the room includes enough power outlets located near your system and controller if the controller isn't using PoE.

Setting up the Poly Studio G62 system

After connecting the peripherals, you can power on and set up your system.

You can set up the system using one of the following methods:

- Using the out of box setup on a Poly TC10 or Poly TC8 touch controller
The Poly TC10 or Poly TC8 must be on version 6.0 or later and connected to the same subnet as the Poly Studio G62 system.
- Accessing the system web interface
- Onboarding the system to Lens Cloud
- [Complete the out of box setup and choose a provider](#)
After connecting peripherals to the Poly Studio G62 , power on the system and complete the out of box set up on a connected Poly TC10 or Poly TC8.

Complete the out of box setup and choose a provider

After connecting peripherals to the Poly Studio G62 , power on the system and complete the out of box set up on a connected Poly TC10 or Poly TC8.

Note Poly strongly recommends that you update your system to the latest Poly VideoOS version. Updating your system ensures that you have access to the latest Poly Studio G62 system features and functionality.

Procedure

- 1 Connect the Poly TC10 or Poly TC8 to a PoE-enabled Ethernet port on the same subnet as the Poly Studio G62 system.

The Poly TC10 or Poly TC8 powers on and displays the out of box screen.

- 2 Connect the Poly Studio G62 system to a PoE+ Class 4 Ethernet port on the same subnet as the Poly TC10 or Poly TC8.

The system powers on and displays the Connect a Controller screen including the system IP address and the serial number.

- 3 On the Poly TC10 or Poly TC8, select **Get Started**.
- 4 Review the network and regional details, then select the right arrow.
- 5 Select **Room Controller** and select the right arrow.

The Poly TC10 or Poly TC8 searches for the Poly Studio G62 system in the out of box state and displays the results.

- 6 Use the system IP address to select your Poly Studio G62 system from the results and select the right arrow.

Alternatively, select **Manually Connect to a Room** and enter the Poly Studio G62 system IP address.

- 7 If the room requires further authentication, the Poly Studio G62 system display shows a collection of shapes. Select the sequence of shapes on the Poly TC10 or Poly TC8 that matches the sequence of shapes on the Poly Studio G62 system display and select **Confirm**.
- 8 Depending on the Poly Studio G62 system configuration, the Poly TC10 or Poly TC8 displays some of the following screens.
 - Poly Lens registration
 - Provider selection
 - Option to update software if a software update is available

The Poly TC10 or Poly TC8 and the Poly Studio G62 system restart into the chosen partner application.

Connecting and Configuring Cameras on Poly Studio G62

The following sections describe how to connect cameras to the Poly Studio G62 system.

- [Connecting cameras to Poly Studio G62](#)
You can connect your Poly Studio G62 to supported Poly cameras and compatible third-party cameras.
- [Configure General Camera Settings](#)
You can configure settings for cameras connected to your system. The system automatically discovers your camera model and displays the relevant settings in the system web interface.

Connecting cameras to Poly Studio G62

You can connect your Poly Studio G62 to supported Poly cameras and compatible third-party cameras.

Note Power off the system before connecting or disconnecting the USB cameras.

Note If you connect an unsupported camera, the system still attempts to show video. Poly can't guarantee that the results are optimal or that the available settings are the same as a supported camera.

Your Poly Studio G62 offers multiple options for connecting cameras to the system including:

- 2 USB Type-A 3.0 ports

Connecting a USB hub to add additional USB ports isn't supported.

If you need to place the camera further than the provided USB cable allows, review the camera release notes for supported extender options.

- 1 LLN port (Doesn't provide power.)

Support for IP LLN camera connections depends on the provider you choose.

Use a CAT5e, CAT6, or CAT7 STP direct Ethernet cable. The cable can be up to 91 m (300 ft) in length.

- HDMI In port for connecting HDMI cameras.

Camera settings and controls aren't available for HDMI cameras.

- [Connecting multiple cameras to Poly Studio G62](#)

Depending on the provider you choose, you can connect and use multiple USB cameras simultaneously.

- [Connecting a Poly Studio E60 to a Poly Studio G62](#)

Poly Studio G62 supports connecting two Poly Studio E60 cameras to the USB Type-A ports on the system.

- [Connecting Poly Studio E70 to the Poly Studio G62 system](#)

You can connect a Poly Studio E70 camera to a Poly Studio G62 system as a USB or IP LLN camera.

- [Connect Poly EagleEye IV USB to the system](#)

The Poly EagleEye IV USB is a suited for large room installations.

- [Connecting an HDMI camera to the system](#)

You can connect an HDMI camera to your Poly Studio G62 to add an additional camera feed to your meeting.

Connecting multiple cameras to Poly Studio G62

Depending on the provider you choose, you can connect and use multiple USB cameras simultaneously.

Poly Studio G62 doesn't support connecting USB and IP cameras simultaneously.

Connecting multiple IP LLN cameras using the Poly G62 LLN port:

- In Poly Video and Zoom Rooms mode, you can connect up to three Poly Studio E70 cameras to the LLN port using a Netgear Pro A/V GSM4210PD switch.
- Microsoft Teams Rooms supports connecting one Poly Studio E70 using the Poly Studio G62 LLN port.

To connect and power one Poly Studio E70 camera, you can use a PoE injector.

Connecting multiple USB cameras to the Poly Studio G62:

- You can connect any two supported cameras to the Poly Studio G62 using the USB Type-A ports.

If you need to connect a USB camera beyond the distance of the USB cable provided with the camera, see the camera release notes for supported extender options.

Connecting a Poly Studio E60 to a Poly Studio G62

Poly Studio G62 supports connecting two Poly Studio E60 cameras to the USB Type-A ports on the system.

Note Poly Studio G62 doesn't support the Poly Studio E60 remote control. Use the Poly camera control app to adjust the camera position.

Poly Studio E60 supports presenter tracking and group framing. You can configure speaker tracking to determine the area of the room the camera focuses on to identify a presenter to track. Use group framing to frame the participants in the room or use the manual controls to move the camera and set position presets.

Table 1. Configurable camera settings on Poly Studio E70

Field	Values
Name	System name Rename the camera to help conference participants identify a camera to select during a call.
Optimized for	Sharpness Motion
Backlight compensation	Enable Disable
White Balance	Auto, 2500K - 6500K
Sharpness	1 - 11

Field	Values
Brightness	1 - 20
Color Saturation	1 - 11
Tracking Mode	Frame Group Frame Presenter Off
Tracking Enabled	Enable Disable

- [Connect a Poly Studio E60 to a Poly Studio G62 using a USB cable](#)
Connect the Poly Studio E60 camera to a Poly Studio G62 USB Type-A port.

Connect a Poly Studio E60 to a Poly Studio G62 using a USB cable

Connect the Poly Studio E60 camera to a Poly Studio G62 USB Type-A port.

Note The system doesn't support hot-plugging USB cameras. Power off the system before connecting the camera.

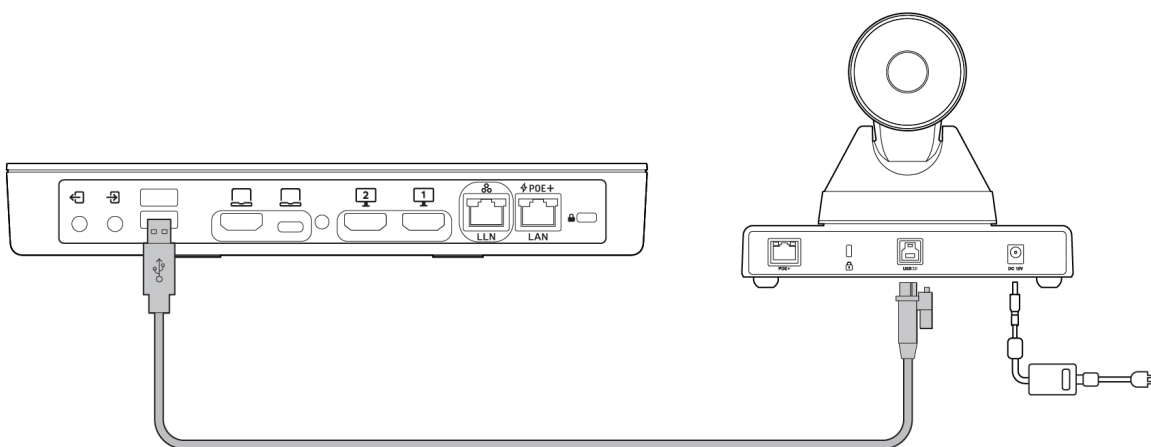

Procedure

- 1 To power on the Poly Studio E60, use the power adapter that ships with the device.

Alternatively, you can connect the Poly Studio E60 to a PoE injector, PoE Ethernet port, or PoE Ethernet switch.

- 2 Connect the Studio E60 USB-B port to a USB Type-A port on the Studio G62 using the USB Type-B to USB Type-A cable supplied with the Studio E60.

Poly Studio E60 becomes the active camera and displays under **Audio/Video > Video Inputs** in the system web interface.

Connecting Poly Studio E70 to the Poly Studio G62 system

You can connect a Poly Studio E70 camera to a Poly Studio G62 system as a USB or IP LLN camera.

Poly Studio E70 is recommended for medium and large room installations.

Table 1. Configurable camera settings on Poly Studio E70

Field	Values
Name	System name Use this setting to help conference participants identify a camera to select during a call.
Optimized for	Sharpness Motion
Tracking Mode	Frame Group Frame Speaker People Framing Off
Tracking Enabled	Enable Disable

Field	Values
Enable DirectorAI Perimeter	<p>Enable</p> <p>Disable</p> <p>When set to Enabled, you can configure DirectorAI Perimeter.</p> <p>Unit (feet/meter) / Tracking Area Depth / Tracking Area Width / Front Exclusion Depth</p>

- [Connect a Poly Studio E70 to Poly Studio G62 system using USB](#)
You can connect Poly Studio E70 as a USB camera to the Poly Studio G62 system.
- [Connect a Poly Studio E70 as an IP camera to the Poly Studio G62 system](#)
Connect a supported Poly IP camera to your Poly Studio G62 system.
- [Connect multiple Poly Studio E70 cameras as an IP LLN camera to a Poly Studio G62 system](#)
You can connect a Poly Studio E70 camera as an IP LLN camera to the Poly Studio G62 system.

Connect a Poly Studio E70 to Poly Studio G62 system using USB

You can connect Poly Studio E70 as a USB camera to the Poly Studio G62 system.

Note Hot plugging a USB camera isn't supported. Power off the system before connecting the camera.

Poly Studio G62 supports connecting two Studio E70 USB cameras.

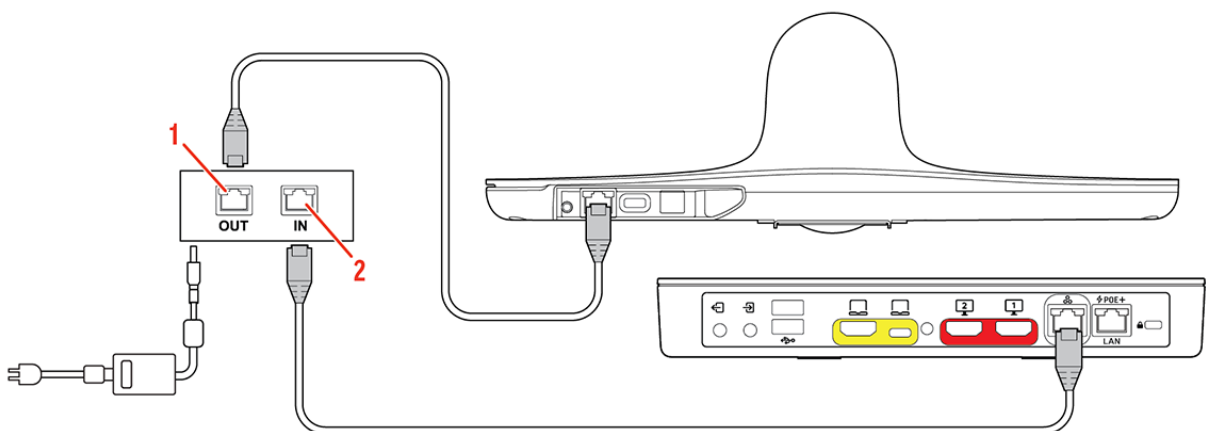

Procedure

- 1 Using the cable provided with the Poly Studio E70, connect the USB Type-C connection to the Poly Studio E70.
- 2 Connect the USB Type-A connection to the Poly Studio G62.
- 3 To power the Poly Studio E70
 - Connect the Poly Studio E70 Ethernet port to a PoE Ethernet port or a PoE Ethernet switch.
 - Use the optional Poly Studio E70 power adapter.

Connect a Poly Studio E70 as an IP camera to the Poly Studio G62 system

Connect a supported Poly IP camera to your Poly Studio G62 system.

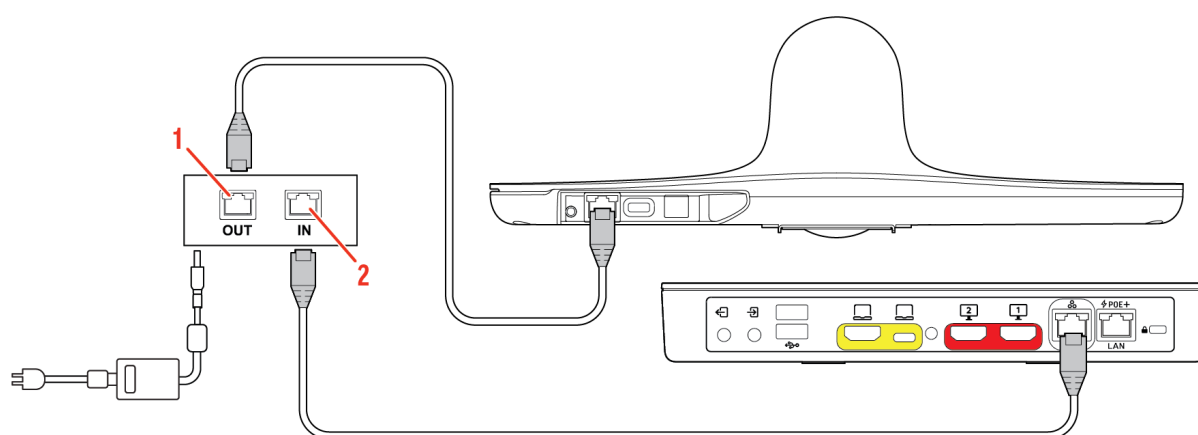

Table 1. PoE Injector Port Descriptions

PoE injector port	Description
Out port	Connects the PoE injector to the Poly Studio E70 camera Ethernet port.
In port	Connects the PoE injector to the Poly Studio G62 LLN port.

Note The Poly Studio G62 system LLN port doesn't provide power to connected peripherals. Use a PoE Ethernet switch or PoE injector to power your Poly IP peripherals.

Procedure

- 1 To provide power and data connectivity, connect a PoE injector to the system.

Alternatively, if you're connecting more than one IP device, use a supported A/V switch.

- 2 Using the Ethernet cable that shipped with your camera, connect the camera to an available port on the Ethernet switch.
- 3 After powering on your system, finish setup by accessing the system web interface.
 - a. In the system web interface, go to **Device Management > Available Devices**.
 - b. Next to the Poly IP camera entry, select **Pair**.

Connect multiple Poly Studio E70 cameras as an IP LLN camera to a Poly Studio G62 system

You can connect a Poly Studio E70 camera as an IP LLN camera to the Poly Studio G62 system.

Note Only Poly Video and Zoom Rooms support connecting multiple Poly Studio E70 cameras using an IP LLN connection. You can connect up to three Poly Studio E70 cameras.

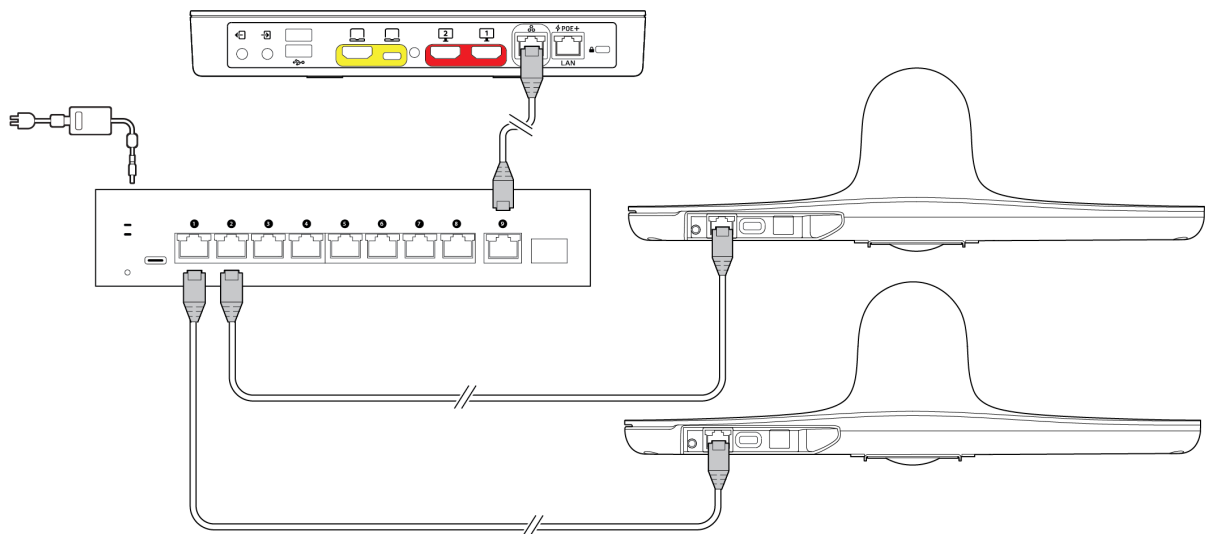

Locate the three link-local network (LLN) ports on the Poly Studio G62 system and connect the Ethernet cable to one of the available ports.

Procedure

- 1 Connect the Poly Studio G62 system LLN port to a PoE Ethernet switch.
- 2 Connect the Ethernet switch to your corporate network.
- 3 Connect the two Poly Studio E70 cameras to the Ethernet switch.
- 4 After setting up your system, access the system web interface and go to **General Settings > Device Management**.

- 5 Locate the Poly Studio E70 from the **Available Devices** list and select **Pair**.

Connect Poly EagleEye IV USB to the system

The Poly EagleEye IV USB is a suited for large room installations.

- [Connect a Poly EagleEye IV USB to the system](#)

Poly Studio G62 supports connecting EagleEye IV USB cameras using USB-A connection.

Connect a Poly EagleEye IV USB to the system

Poly Studio G62 supports connecting EagleEye IV USB cameras using USB-A connection.

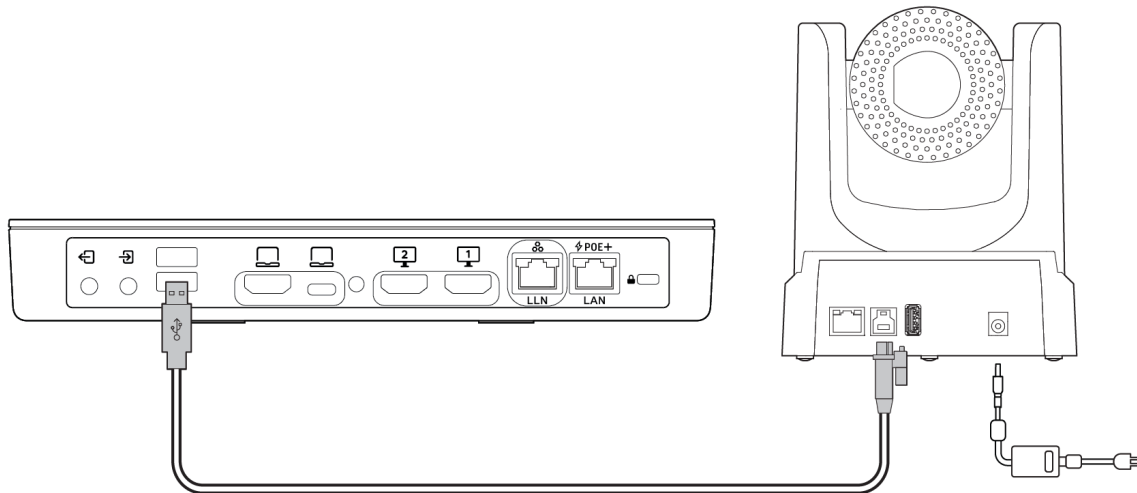

Procedure

- 1 Use the USB cable that shipped with the EagleEye IV USB to connect the EagleEye IV USB Type-B port to a USB Type-A port on the Poly Studio G62.
- 2 Connect the EagleEye IV USB to power using the power supply that shipped with the camera.

Connecting an HDMI camera to the system

You can connect an HDMI camera to your Poly Studio G62 to add an additional camera feed to your meeting.

Note When you set HDMI Input to **People**, the HDMI audio isn't captured or transmitted to the far side. If you require HDMI for your configuration, use another available input source such as USB or 3.5 mm TRS input port.

You can connect a camera or content source to the HDMI In port on the Poly Studio G62. In the system web interface, you can set the HDMI content source as **People** to include the HDMI input as an available camera.

When you connect an HDMI camera, settings and camera framing aren't available. You can choose to set input as People or Content.

Table 1. Configurable settings for HDMI content input

Field	Values
Display as	<p>Content (default)—Presents the HDMI input as content. The system indicates that content is available.</p> <p>People—Presents the HDMI input as a camera feed into the meeting.</p>
Name	Use this setting to help conference participants identify a camera to select during a call.
Optimized for	<p>Sharpness—Use when displaying content.</p> <p>Motion—Use with an HDMI camera.</p>
Enable HDMI Auto-Start	<p>Enable (default)</p> <p>Disable</p> <p>When enabled, content is immediately presented when an HDMI content source is connected to the system.</p>

- [Connect an HDMI camera to the system](#)

You can connect an HDMI camera to your Poly Studio G62.

Connect an HDMI camera to the system

You can connect an HDMI camera to your Poly Studio G62.

Procedure

- 1 Connect one end of the HDMI cable to the Poly Studio G62 HDMI In port.
- 2 Connect the other end of the HDMI cable to the HDMI camera or content source.

Configure General Camera Settings

- [Configuring Video Input Settings](#)

Customize your video input settings, such as enabling connected cameras, adjusting camera orientation, or specifying whether people or content display on connected monitors.

You can configure settings for cameras connected to your system. The system automatically discovers your camera model and displays the relevant settings in the system web interface.

See the latest *Poly VideoOS Release Notes* for specific information about the cameras you can use with your system.

Note If you connect an unsupported camera, the system still attempts to show video. Poly can't guarantee that the results are optimal or that the available settings are the same as a supported camera.

Procedure

- 1 In the system web interface, go to **Audio/Video > Video Inputs > General Camera Settings**.
- 2 Configure the following settings:

Table 1.

Setting	Description
Allow Other Participants in a Call to Control Your Camera	Specifies whether the far site can pan, tilt, or zoom the near-site camera. When you enable this setting, a user at the far site can control the framing and angle of the camera for the best view of the near site. This is also called Far End Camera Control (FECC).
Power Frequency	<p>Note To avoid power frequency issues with your system, choose a location.</p> <p>Specifies the power-line frequency for your system.</p> <p>Your system typically defaults to the correct power-line frequency based on the video standard used in the country where it's located. This setting helps you adapt the system to areas where the frequency doesn't match the video standard. You might also need to change this setting to avoid flicker from fluorescent lights in the room.</p>

Setting	Description
Enable Camera Preset Snapshot Icons	<p>Enables the use of snapshot icons that represent camera presets.</p> <p>To see a preset icon, you must enable this setting before configuring the preset.</p>
Camera sleep mode	<p>Specifies a sleep mode for your camera.</p> <p>Fast Wake Up: The camera provides an image as soon as the monitor wakes. While asleep, the camera faces forward.</p> <ul style="list-style-type: none"> ● When you set sleep Display to Black, an image more quickly displays, but be aware that this uses maximum power. ● When you set sleep Display to No Signal, the display synchronizes with the system. This can take a few seconds but may conserve energy depending on the monitor. <p>Save Energy: Puts the camera into standby mode to save power (the camera spins to the rear and faces down). This option applies only when a camera is connected to the system (except the EagleEye Producer or EagleEye Director camera).</p> <ul style="list-style-type: none"> ● When you set sleep Display to Black, it takes a few seconds for the camera to send an image. ● When you set sleep Display to No Signal, the camera is already sending an image by the time the display synchronizes with the system.
Camera Sleep Mode	<hr/> <p>Note Don't configure sleep settings in Partner Mode.</p> <hr/>

Setting	Description
Current People Camera	<p>Select the camera or HDMI input to be used for conferencing.</p> <hr/> <p>Note When HDMI Input is set as People source, the HDMI audio is not captured or transmitted to the far side. If HDMI audio is required in this configuration, use another available input source such as USB Type-A or 3.5 mm TRS input.</p> <hr/>
Enable User Camera Selection	Allow the user to select primary camera from the TC8, TC10, or the local interface.

3 Select **Save**.

Configuring Video Input Settings

Customize your video input settings, such as enabling connected cameras, adjusting camera orientation, or specifying whether people or content display on connected monitors.

Your system supports two video inputs settings: **People** and **Content**.

For example, a people source has pan, tilt, zoom, and near/far camera control settings, while a content source doesn't.

Camera settings aren't available to users during a meeting. Poly recommends adjusting these settings as part of setting up and configuring the video system in your environment.

- [Configure General Video Input Settings](#)

Customize your video input settings to provide the best meeting experience with your cameras.

- [Configure HDMI Input Settings](#)

Configuring HDMI input as people input enables you to take full advantage of the system's available transmit bandwidth and provides better picture quality for shared content.

- [Configure Camera Tracking Settings](#)

Poly camera tracking technology can automatically frame groups of people or the active speaker in medium and large rooms.

- [Poly DirectorAI Perimeter](#)

Define the area used by your video system to track meeting participants when a tracking mode is enabled.

- [Select Frame Presenter on Poly Studio E60](#)

You can configure your Poly Studio E60 camera to track a presenter.

Configure General Video Input Settings

Customize your video input settings to provide the best meeting experience with your cameras.

Note The system only displays settings that apply to your camera. For example, you don't see tracking options if your camera doesn't support tracking. For a list of supported configurations for Poly cameras, see the camera information in **Video Integration**.

Procedure

- 1 In the system web interface, go to **Audio/Video > Video Inputs**.
- 2 Go to the input of a connected camera.
- 3 Configure the following settings that apply to your camera:

Table 1.

Setting	Description
Input Format	Specifies the source type of the device. This setting is read-only unless the system doesn't detect the device.
Name	Enter a name for the camera or device.
Model	Displays the type of device connected to the system.
Optimized for	Specifies optimization preferences for the video input. <ul style="list-style-type: none">● Sharpness: Gives preference to resolution over frames per second. With this setting, moderate-to-heavy motion at low call rates can cause some frames to drop.● Motion: Gives preference to frames per second over resolution.
Backlight Compensation	Specifies if the camera automatically adjusts for a bright background. Use backlight compensation when the subject appears darker than the background.
Skin Enhancement	Enables or disables natural skin color enhancements for participants.
Wide Dynamic Range	Enables or disables re-exposure according to the framed area instead of full view.

Setting	Description
Framing Size	Specifies the framing view. <ul style="list-style-type: none"> ● Wide: Establishes a wide view of meeting participants. ● Medium: (Default group framing view) Establishes a medium view of meeting participants. ● Tight: Establishes a close-up view of meeting participants.
Sharpness	Adjusts the video's overall clarity.
Brightness	Adjusts the video brightness.
Color Saturation	Adjusts the color saturation.
Maximum Digital Zoom Factor	Specifies the maximum digital zoom factor for the camera.

4 Select **Save**.

Configure HDMI Input Settings

Configuring HDMI input as people input enables you to take full advantage of the system's available transmit bandwidth and provides better picture quality for shared content.

Procedure

- 1 In the system web interface, go to **Audio/Video > Video Inputs**.
- 2 Configure the following **HDMI Input** settings:

Setting	Description
Display as	<p>Specifies the display type. You can't change this setting if the system is in Device Mode or if the HDMI input is set to People and the system is currently using the source as the people camera.</p> <ul style="list-style-type: none"> ● People: Sends content as a camera source with the highest levels of transmit bandwidth. ● Content: Sends content as a content source with a lower bandwidth and enables you to use the system's annotation tools.
Name	Enter a custom name for the HDMI input.
Optimized for	<p>Specifies optimization preferences for the video input.</p> <ul style="list-style-type: none"> ● Sharpness: Gives preference to resolution over frames per second. With this setting, moderate-to-heavy motion at low call rates can cause some frames to drop. ● Motion: Gives preference to frames per second over resolution.
Enable HDMI Auto-Start	<p>By default, the system automatically displays content when a participant connects an HDMI input source to the system.</p> <p>When HDMI Auto-Start is disabled, the participant chooses when to display content by accessing the Content screen and selecting an active content stream.</p>

3 Select **Save**.

Configure Camera Tracking Settings

Poly camera tracking technology can automatically frame groups of people or the active speaker in medium and large rooms.

Note Available camera tracking settings depend on the camera you're using. For a list of available settings, review the topic for connecting your camera in the *Video integration* section.

Procedure

- 1 In the system web interface, go to **Audio/Video > Video Inputs**.
- 2 Go to the camera's settings and specify a **Tracking Mode**.
 - **Frame Group**: The camera automatically locates and frames all the people in the room.
 - **Frame Speaker**: The camera automatically locates and frames the active speaker. When someone else starts speaking, the camera switches to that person.

Note When you mute your microphone, the camera tracking mode automatically switches to **Frame Group**.

- **People Framing**: The camera tracks up to six individuals placing them in individual frames. If the camera detects more than six people, the camera places all participants in a single frame.
 - **Off**: Disables automatic tracking. You must control the camera manually.
- 3 Set **Tracking Enabled** to **On** or **Off**.
 - 4 Select **Save**.

Poly DirectorAI Perimeter

Define the area used by your video system to track meeting participants when a tracking mode is enabled.

Note In some environments, it's possible that the width defined in the system may not exactly match the area you're defining. When using this feature, Poly recommends testing and adjusting the perimeter settings as necessary. You can provide feedback on the DirectorAI Perimeter feature by visiting the [Poly Lens Feedback Portal](#).

Your Poly system uses the area visible by the camera to locate and track meeting participants in a conference room. In situations such as a conference room with glass walls, the area visible by the camera may extend beyond the conference room.

Using DirectorAI Perimeter, you can ensure that the camera only tracks participants within the defined conference room area.

If a participant moves out of the perimeter, the camera no longer tracks their movement.

- [Define the DirectorAI Perimeter](#)

Define the area used by your system to track participants in a conference room.

Define the DirectorAI Perimeter

Define the area used by your system to track participants in a conference room.

Procedure

- 1 In the system web interface, go to **Audio/Video > Video Inputs**.
- 2 Select **Enable DirectorAI Perimeter**.
- 3 Using the drop down, choose to use either **Metric** or **Feet** to define the tracking area.
- 4 Enter a tracking width, tracking depth, and the front exclusion depth.
- 5 Select **Save**.

Select Frame Presenter on Poly Studio E60

- [Configure the Frame Presenter tracking window](#)

You can configure the area the camera sends to the far end when no presenter is present and the area in which to look for a presenter.

You can configure your Poly Studio E60 camera to track a presenter.

Procedure

- 1 In the system web interface, go to **Audio/Video > Video Inputs**.
- 2 In the Poly Studio E60 settings, go to **Tracking Mode** and select **Frame Presenter**.

Configure the Frame Presenter tracking window

You can configure the area the camera sends to the far end when no presenter is present and the area in which to look for a presenter.

The Poly DirectorAI frame presenter feature provides two parameters:

When a presenter enters the configured presenter tracking zone, the camera tracks the speaker until the speaker leave the presenter tracking zone.

- **Stage Frame**—The camera area presented to the far end when no speaker is in the presenter tracking zone.
- **Presenter Tracking Zone**—The area the camera uses to detect a speaker to initiate presenter tracking. The presenter tracking zone is a subset of the stage frame and cannot be larger than the stage frame.

Procedure

- 1 In the system web interface, go to **Audio/Video > Video Inputs**.
- 2 Select **Configure** next to **Setup Presenter Tracking Zones**.
- 3 Move, reduce, or expand the blue stage frame to set the area you want the camera present when no presenter is detected.
- 4 Move, reduce, or expand the presenter tracking zone to set the area you want the camera to use for detecting a speaker.

Connecting and Configuring Audio Peripherals on Poly Studio G62

You can connect Poly Studio G62 to multiple types of audio input and output devices.

Note Microsoft Teams Rooms Certified Peripherals aren't compatible with Microsoft Teams Rooms for Android.

Note The system supports connecting one USB audio device. Connecting a second audio capable USB device to the system may result in no audio sent to the primary intended audio device.
For example, you can't connect a USB audio DSP and a USB camera with integrated audio (microphone or speakers) or an audio capable HDMI to USB such as an INOGENI 4K2USB3.

Poly Studio G62 supports the following audio integrations:

- Poly IP microphones
- 3.5 mm output and input
- USB audio DSPs
- Poly Trio C60
- [Connecting audio devices to Poly Studio G62](#)
You can connect Poly IP microphones, USB audio DSPs, an HDMI monitor, Poly Trio C60, or 3.5 mm audio devices to Poly Studio G62 for audio input and output.
- [Configuring audio settings](#)
Configure audio settings for peripherals connected to Poly Studio G62.

Connecting audio devices to Poly Studio G62

You can connect Poly IP microphones, USB audio DSPs, an HDMI monitor, Poly Trio C60, or 3.5 mm audio devices to Poly Studio G62 for audio input and output.

- [Connect IP microphones to the Poly Studio G62 system](#)
Connect up to three Poly IP microphones to the Poly Studio G62 system.
- [Connect a Poly Trio C60 to Poly Studio G62](#)
Poly Studio G62 supports connecting Poly Trio C60 speakerphones for use as a microphone and speaker.
- [Connect a JBL Pro SoundBar PSB-1 to Poly Studio G62](#)
Connect a JBL Pro SoundBar PSB-1 to your system for use as an audio output device.
- [Connect a 3.5mm audio output device to the Poly Studio G62 system](#)
Connect an audio output device such as an amplifier or sound bar to your system using the 3.5mm audio output port.
- [Connecting an external amplifier to the Poly Studio G62 3.5mm output](#)
Poly supports using the 3.5 mm audio output port with an amplifier, but Poly doesn't support the configuration and tuning of such devices.
- [Using a USB audio DSP with Poly Studio G62](#)
When you connect a USB audio DSP, the DSP handles all audio input and output for your system. The system doesn't send audio to the system monitors or through the 3.5 mm output.

Connect IP microphones to the Poly Studio G62 system

Connect up to three Poly IP microphones to the Poly Studio G62 system.

Note The Poly Studio G62 system LLN port doesn't provide power to connected peripherals. For one IP microphone, you can use a PoE injector. To connect multiple IP microphones, use a supported A/V Ethernet switch such as a Netgear A/V Line M4250 GSM4210PD.

The system doesn't support connecting Poly IP microphones and a Poly expansion microphone simultaneously.

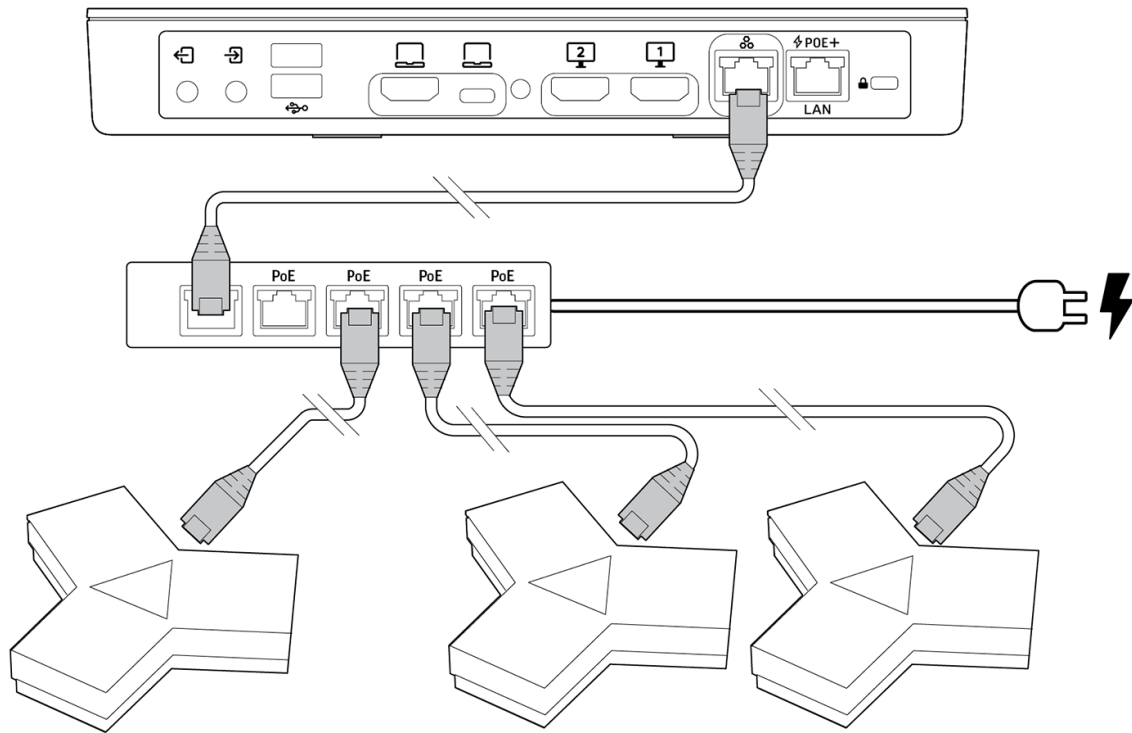

Procedure

- 1 Connect a PoE injector or supported Ethernet switch, such as a Netgear A/V Line M4250 GSM4210PD Ethernet switch, to the LLN port on the Poly Studio G62 system.

If you're connecting only one Poly IP microphone, you can use a PoE injector.

- 2 Connect the IP microphone to the PoE injector Out port.

Alternatively, you can connect the microphones using a CAT5e, CAT6, or CAT7 direct STP Ethernet cable. The cable can be up to 91 m (300 ft) in length.

- 3 Connect the PoE injector In port to the Poly Studio G62 LLN port and connect the PoE injector power cable.
- 4 After powering on your system, finish setup by accessing the system web interface.
 - a. In the system web interface, go to **Device Management > Available Devices**.
 - b. Next to the Poly IP microphone entry, select **Pair**.
 - c. If your system is in Zoom Rooms mode, go to **Settings > Room Profile > Microphone** and disable the following options:

- a. Software Audio Processing

- b. Noise Suppression

Connect a Poly Trio C60 to Poly Studio G62

Poly Studio G62 supports connecting Poly Trio C60 speakerphones for use as a microphone and speaker.

When connecting a Poly Trio C60, observe the following:

- You can't use a Poly Trio C60 as an audio device if your system is connected to Wi-Fi as the primary network.
- Microsoft Teams Rooms supports one Poly Trio C60 as an audio device only.
- In Poly Video mode, you can connect up to four Poly Trio C60s for use as audio devices and system controllers.

Procedure

- 1 Connect the Poly Trio C60 to a PoE switch on the same subnet as the Poly Studio G62.

Don't connect the Poly Trio C60 to an Ethernet switch connected to the Poly Studio G62 LLN port.

- 2 In the Poly Trio C60 local interface, set the **Networked Device Role** to **Device**.
- 3 In the Poly Studio G62 system web interface, go to **General Settings > Device Management** and locate the Poly Studio C60 under **Available Devices**.
- 4 Select **Pair**
- 5 If your system is in Microsoft Teams Rooms mode, go to **Audio / Video > Audio** and select **Enable Poly Trio Audio (Speakers and Microphones)**.

Connect a JBL Pro SoundBar PSB-1 to Poly Studio G62

Connect a JBL Pro SoundBar PSB-1 to your system for use as an audio output device.

Note Don't use the remote control that ships with the JBL Pro SoundBar PSB-1. Use the volume controls on your Poly TC10 or Poly TC8 touch controller to adjust the system volume.

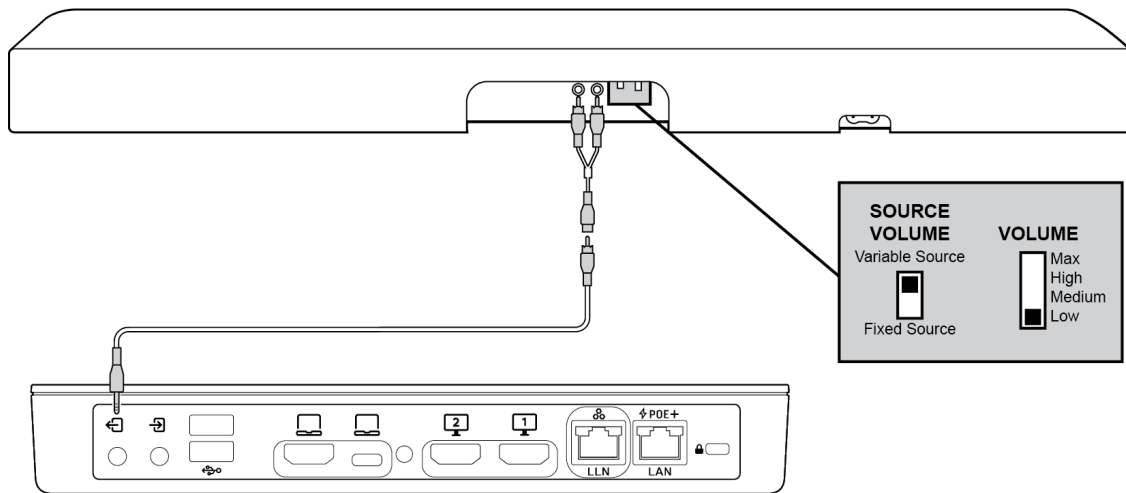

Procedure

1 On the back of the JBL Pro SoundBar PSB-1, set the **Source Volume:** and **Volume** switches to the following settings:

- Source Volume: **Variable Source**
- Volume: **Low**

2 Connect the provided RCA cable to the provided RCA splitter cable.

3 Connect the RCA splitter cable to the white and red RCA connections on the sound bar.

4 Connect the 3.5 mm connector to the 3.5 mm output port on the Poly Studio G62 system.

Make sure the 3.5 mm connector is fully seated in the connector.

5 In the system web interface, go to **Audio/Video > Audio > Line Out**.

6 Select **Variable**.

7 For **Speaker Options**, select **Line Out**.

8 In the system web interface, go to **Audio/Video > Audio > General Audio Settings**.

9 Verify that **Transmission Audio Gain (dB)** is set to **0**.

Connect a 3.5mm audio output device to the Poly Studio G62 system

Connect an audio output device such as an amplifier or sound bar to your system using the 3.5mm audio output port.

External amplifiers may have other settings that must be changed. Third-party amplifiers and speakers should be tuned for proper operation per manufacturer guidelines and audio industry standards.

If your audio device has an option for fixed or variable audio, choose variable to allow audio output adjustment from the system controller.

Procedure

- 1 Connect the speaker to the 3.5mm output port on the system.
Make sure the 3.5mm connector is fully seated in the connector.
- 2 In the system web interface, go to **Audio/Video > Audio > Line Out**.
- 3 Select **Variable**.
- 4 From the **Speaker Options** drop down menu, choose **Line Out**.
- 5 Go to **Audio/Video > Audio > General Audio Settings**.
- 6 Verify that **Transmission Audio Gain (dB)** is set to 0dB.

Connecting an external amplifier to the Poly Studio G62 3.5mm output

Poly supports using the 3.5 mm audio output port with an amplifier, but Poly doesn't support the configuration and tuning of such devices.

External amplifiers may have other settings that must be changed. Tune third-party amplifiers and speakers for proper operation per manufacturer guidelines and audio industry standards.

Using a USB audio DSP with Poly Studio G62

When you connect a USB audio DSP, the DSP handles all audio input and output for your system. The system doesn't send audio to the system monitors or through the 3.5 mm output.

Note The Shure P300 audio DSP is a certified peripheral with Microsoft Teams Rooms on Android.

When using a USB audio DSP with your system, observe the following:

- If you connect an incompatible USB audio DSP, the system won't recognize it.
- When you connect a USB audio DSP, and the system recognizes it, **USB Speakerphone Input** and **USB Speakerphone Output** display in the system web interface.
- All audio sends through the USB Type-A port. Other audio output and input, except for 3.5 mm input, are disabled.
- The system only supports one audio source connected to a USB Type-A port.
- You can use NoiseBlockAI or Sound Reflection Reduction.
- [Connect a USB audio DSP to your Poly Studio G62 system](#)
Connect a supported USB audio DSP to your system to handle audio input and output.
- [Connect a Shure P300 audio DSP to the system](#)
Connect the Shure P300 audio to Poly Studio G62.

- [Connect a Biamp USB audio DSP USB to a Poly Studio G62](#)
Poly Studio G62 is compatible with Biamp DSP USB audio processors.
- [Connect a QSC Core Series audio processor to a Poly Studio G62](#)
Poly Studio G62 is compatible with QSC Core Series audio processors

Connect a USB audio DSP to your Poly Studio G62 system

Connect a supported USB audio DSP to your system to handle audio input and output.

Procedure

- 1 Connect a USB cable from the audio DSP to a USB Type-A connection on the system.
- 2 In the system web interface, go to **Audio / Video** > **Audio** and enable the **Enable USB Audio** check box.

The system saves your changes automatically.

Connect a Shure P300 audio DSP to the system

Connect the Shure P300 audio to Poly Studio G62.

Note Once you connect a DSP to the Poly Studio G62 system, the processor handles all audio. You can't use speakers and microphones that aren't connected to the processor.

For more information on setting up a Shure P300 audio DSP, refer to the [Shure documentation](#).

Procedure

- 1 Connect a cable from the Shure P300 USB Type-B port a Poly Studio G62 Type-A port.

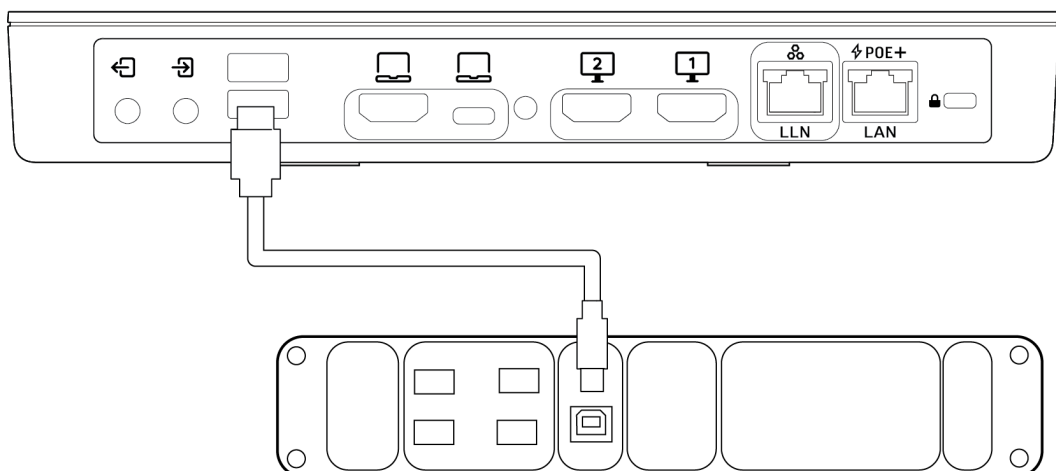

2 In the Poly Studio G62 system web interface, go to **Audio / Video > Audio** and select the **Enable USB audio** check box.

3 To use the audio DSP noise cancellation features, set **NoiseBlockAI Options** to **Off**.

Alternatively, you can use Poly NoiseBlockAI or Sound Reverb Reduction.

To use Poly noise suppression, disable noise suppression processing on the audio DSP.

Connect a Biamp USB audio DSP USB to a Poly Studio G62

Poly Studio G62 is compatible with Biamp DSP USB audio processors.

Note Poly provides recommended setup instructions for third-party audio DSP, but isn't responsible for helping with DSP configurations.

Procedure

1 Connect the Biamp DSP USB audio processor USB Type-B port a Poly Studio G62 Type-A port.

2 In the Poly Studio G62 system web interface, go to **Audio / Video > Audio** and select the **Enable USB audio** check box.

3 To use the audio DSP noise cancellation features, set **NoiseBlockAI Options** to **Off**.

Alternatively, you can use Poly NoiseBlockAI or Sound Reverb Reduction.

To use Poly noise suppression, disable noise suppression processing on the audio DSP.

4 Set up a stereo USB Audi Block 2x2 in the DSP platform and connect into an AEC microphone audio chain as per the DSP instructions.

5 Optional: Connect 'Logic Pins' for Microphone Mute State status and triggering.

6 Update the DSP firmware to the latest version.

7 In creating the USB Audio I/O, in USB Initialization, under Connection Type, select **Speakerphone: Disables Computer AEC**.

8 After USB initialization is complete, in DSP Properties, disable **Asynchronous Synchronization** be selecting **False**.

Connect a QSC Core Series audio processor to a Poly Studio G62

Poly Studio G62 is compatible with QSC Core Series audio processors

Note IN the QSC USB HID Conferencing Block, only the Phone Mute and MUTE LED are currently functional. Call Accept, Call Decline, Off Hook LED, and RING LED aren't functional and can be ignored.

Procedure

1 Connect the QSC Core Series audio processor Type-B port a Poly Studio G62 Type-A port.

- 2 In the Poly Studio G62 system web interface, go to **Audio / Video** > **Audio** and select the **Enable USB audio** check box.
- 3 To use the audio DSP noise cancellation features, set **NoiseBlockAI Options** to **Off**.

Alternatively, you can use Poly NoiseBlockAI or Sound Reverb Reduction.
To use Poly noise suppression, disable noise suppression processing on the audio DSP.
- 4 Set up a stereo USB Audi Block 2x2 in the DSP platform and connect into an AEC microphone audio chain as per the DSP instructions.
- 5 Optional: Connect 'Logic Pins' for Microphone Mute State status and triggering.

Configuring audio settings

Configure audio settings for peripherals connected to Poly Studio G62.

- [Configuring audio output settings](#)
You have different options to play audio on your system to fit your setup.
- [Configuring audio input settings](#)
You can connect several types of microphones to your system.

Configuring audio output settings

You have different options to play audio on your system to fit your setup.

You can connect an external speaker system to the Poly Studio G62 system to provide more volume and comprehensive sound in large rooms.

See your system setup sheet for connection details. Make sure that you power off the system before connecting anything to it.

The following audio outputs are supported:

- **3.5 mm output:** Stereo output to a device such as a soundbar or amplifier. Depending on your setup, you can specify if the sound plays from the room display, 3.5 mm line out, or both.
- **Poly Trio C60 speakers:** Available in Poly Video mode, Device Mode, and Teams Rooms when you pair a Trio with the video system.
- **USB audio DSP:** Stereo output to a USB audio DSP such as a Shure P300. When you connect a USB audio DSP, all audio input and output are handled by the audio DSP.
- [Configure audio output for HDMI and 3.5 mm audio](#)
You can choose a specific output configuration for HDMI and 3.5 mm audio.
- [Using Poly Trio Speakers](#)
When you pair a Poly Trio system with your video system, you can use the phone's speakers as the audio output for the room.

Configure audio output for HDMI and 3.5 mm audio

- [Set the 3.5 mm Audio Output mode](#)

Specify how volume is controlled for a device connected to the line out port.

You can choose a specific output configuration for HDMI and 3.5 mm audio.

Procedure

- 1 In the system web interface, go to **Audio / Video > Audio > Audio Output**.
- 2 Choose from:
 - **TV Speakers:** Sound is sent to the speakers on the monitor connected to HDMI port 1 on the system. The 3.5 mm audio output is turned off.
 - **Line Out:** Sound is sent through the 3.5 mm audio output. Sound is turned off for the HDMI output.
 - **TV Speakers and Line Out:** Sound is output to the HDMI output and the 3.5 mm audio output.

Changes take effect immediately.

Set the 3.5 mm Audio Output mode

Specify how volume is controlled for a device connected to the line out port.

Procedure

- 1 In the system web interface, go to **Audio/Video > Audio > Line Out**.
- 2 Choose one of the following **Output Mode** options:
 - **Variable:** Enables users to change the volume.
 - **Fixed:** Sets the volume to the audio level configured for the system.

Using Poly Trio Speakers

When you pair a Poly Trio system with your video system, you can use the phone's speakers as the audio output for the room.

Also note the following when using Poly Trio speakers with your video system:

- You can't use a Poly Trio if your system is connected to Wi-Fi as the primary network.
- In Microsoft Teams Rooms mode:

- The Trio Teams Rooms controller offers limited functionality and isn't supported as a Teams Rooms controller.
- Use a connected TC8/TC10 or touch screen monitor to control your Microsoft Teams Rooms environment.
- [Configure a Poly Trio C60 speakerphone for Pairing](#)
To pair with a video system, you must configure your Poly Trio C60 speakerphone base profile and device role.
- [Choose Speakers When Paired with Poly Trio C60](#)
In or out of a call, you can toggle whether you want to use Poly Trio C60, connected monitor, or video system speakers.

Configure a Poly Trio C60 speakerphone for Pairing

To pair with a video system, you must configure your Poly Trio C60 speakerphone base profile and device role.

Procedure

- 1 On the Poly Trio C60 speakerphone local interface, go to **Settings > Advanced > Administration Settings > Network Configuration**.
- 2 Set the **Base Profile** to **Generic**.
- 3 After the phone restarts, go to **Settings > Advanced > Networked Devices**.
- 4 Set **Networked Device Role** to **Device**.

The system automatically restarts.

Choose Speakers When Paired with Poly Trio C60

In or out of a call, you can toggle whether you want to use Poly Trio C60, connected monitor, or video system speakers.

Procedure

- 1 In the system web interface, go to **Audio/Video > Audio > Audio Output**.
- 2 Choose one of the following **Speaker Options**:
 - **Phone Speakers**: Use only your Poly Trio C60 system speakers.
 - **TV Speakers**: Use only the speakers on your connected monitors.

Configuring audio input settings

You can connect several types of microphones to your system.

The following audio inputs are supported:

- IP-based Poly microphone peripherals:
 - **Poly IP Table Microphone**
 - **Poly IP Ceiling Microphone**
- **3.5 mm**: Analog stereo input used to share audio from a device or microphone. Depending on your setup, you can specify if sound from this input plays in the room and at far sites or just at far sites.
- **HDMI**: Used to share audio (along with content) from a device. Sound from this input plays in the room and at far sites.
- **Trio Microphones**: Available in Poly Video mode, Device Mode, and Teams Rooms when you pair a Trio with the video system.
- **USB audio DSP**: When you connect a USB audio DSP, all audio input and output is handled by the audio DSP.
- [Configure 3.5 mm audio input](#)
Specify how the system routes and controls audio from the 3.5 mm stereo input.
- [Using Poly Trio Microphones](#)
The video system automatically configures Poly Trio microphones when you pair the phone.
- [Sound Reflection Reduction](#)
Sound Reflection Reduction is a NoiseBlockAI option that reduces audible reverberations caused by environmental factors, including tables and glass walls. Audible reverberations result in reduced audio quality for audio transmitted to the far side.
- [Polycom Acoustic Fence](#)
- [Configure HDMI Audio Input](#)
You can specify the audio input level for your system's HDMI connections (for example, audio from an HDMI-connected laptop).

Configure 3.5 mm audio input

Specify how the system routes and controls audio from the 3.5 mm stereo input.

Note If you connect a DSP using 3.5 mm the system will not reflect the mute states of the DSP microphones. Only USB-connected DSPs will properly reflect the mute state. The USB connection provides the necessary data channel for the sharing of this type of information.

Procedure

- 1 In the system web interface, go to **Audio/Video > Audio > Audio Input > 3.5 mm**.

Note When you connect a 3.5 mm audio device, make sure that **USB Audio** isn't enabled. Enabling USB audio when you have a 3.5 mm audio device connected may result in echoes on the far side.

- 2 For **Audio Input Level**, set the left and right channel levels by choosing a value from 0 to 10.

The audio meters display the input's left and right channel levels.

- 3 Choose one of the following **Playback Options**:

Table 1. Playback Options

Option	Description	Result
Play back to All Locations	Select this option if you're sending audio from a device.	<ul style="list-style-type: none"> ● Near and far sites hear the 3.5 mm stereo input. ● You can't mute audio or control echo cancellation.
Play back to Far Sites	Select this option if you're using an external digital signal processor (DSP), such as Polycom SoundStructure, which provides mute controls and echo cancellation.	<ul style="list-style-type: none"> ● Only far sites hear the 3.5 mm stereo input (there is no associated video content). ● You can't mute audio or control echo cancellation through the system.
Play back to Far Sites, Mute Controlled	Select this option if you want to perform activities like sharing music from a mobile phone to call participants.	<ul style="list-style-type: none"> ● Only far sites hear the 3.5 mm stereo input (there is no associated video content). ● You can mute audio but can't control echo cancellation.

Option	Description	Result
Play back to Far Sites, Mute Controlled, Echo Canceled *	<p>Select this option if you're using a line-level microphone.</p> <hr/> <p>Note The microphone must provide the line-level signal to work.</p> <hr/>	<ul style="list-style-type: none"> ● Only far sites hear the 3.5 mm stereo input (there is no associated video content). ● You can mute audio and control echo cancellation. ● Mic-level inputs aren't supported. ● You can use NoiseblockAI or Sound Reflection reduction.

4 Verify that **USB Audio** is disabled.

Using Poly Trio Microphones

The video system automatically configures Poly Trio microphones when you pair the phone.

Note Poly Trio microphones are disabled by default if your system is using Microsoft Teams.

You can only use the following microphones in addition to the Poly Trio microphones:

Also note the following when using Poly Trio microphones with your video system:

- You can't use Poly IP audio devices, including table and ceiling microphones.
- Polycom Acoustic Fence technology isn't available.
- Polycom StereoSurround isn't available.
- The audio input level (mono channel meter) displays in the local interface and system web interface.
- You can pair up to four Poly Trios C60 with your system in supported provider modes.
- You can't use a Poly Trio if your system is connected to Wi-Fi as the primary network.
- In Microsoft Teams Rooms mode:
 - The Teams Rooms controller on Poly Trio C60 offers limited functionality and isn't supported as a Teams Rooms controller.

- Use a connected Poly TC10, Poly TC8 or touch screen monitor to control your Microsoft Teams Rooms environment.
- [Configure NoiseBlockAI When Paired with Poly Trio](#)
To use Poly NoiseBlockAI when paired with a Poly Trio, enable the setting on your video system. There's nothing to configure on the phone.

Configure NoiseBlockAI When Paired with Poly Trio

To use Poly NoiseBlockAI when paired with a Poly Trio, enable the setting on your video system. There's nothing to configure on the phone.

Procedure

- 1 In the system web interface, go to **Audio/Video > Audio > General Audio Settings**.
- 2 Select the **Enable Keyboard Noise Reduction and NoiseBlock** check box.

Sound Reflection Reduction

Sound Reflection Reduction is a NoiseBlockAI option that reduces audible reverberations caused by environmental factors, including tables and glass walls. Audible reverberations result in reduced audio quality for audio transmitted to the far side.

If you hear echo or reverb with **NoiseBlockAI** enabled, Poly recommends using **Sound Reflection Reduction**.

Sound Reflection Reduction supported configurations

Note	Disable noise reduction on your DSP when using Sound Reflection Reduction or NoiseBlockAI options.
Note	On the system, Sound Reflection Reduction applies, when enabled, to the current active conference microphone. The same control for choosing NoiseBlockAI, Sound Reflection Reduction, or off setting applies to only one of these pathways automatically based on the audio configuration connected.

Sound Reflection Reduction supports the following configurations:

- When you disable Polycom StereoSurround, you can use Sound Reflection Reduction. If you enable Polycom StereoSurround the system uses NoiseBlockAI.
- On Poly Studio G62 using:

- Poly IP table or ceiling microphones
 - Poly Trio C60
 - USB audio DSP
 - 3.5 mm input
- [Enable Sound Reflection Reduction](#)
Eliminate echoes heard on the far end due to room conditions and materials by enabling Sound Reflection Reduction.

Enable Sound Reflection Reduction

Eliminate echoes heard on the far end due to room conditions and materials by enabling Sound Reflection Reduction.

Procedure

- 1 In the system web interface, go to **Audio / Video > Audio > NoiseBlockAI Options**.
- 2 In the drop-down menu, select **Sound Reflection Reduction**.

Polycom Acoustic Fence

Polycom Acoustic Fence technology provides the following:

- Mutes sounds outside the fence when no one is speaking inside it
- Lowers sounds outside the fence by 12 dB when someone is speaking inside it
- Mutes speakers when someone leaves the fenced area
- Enables you to adjust the width of the audio fence beam to define the area where sounds are picked up

For Poly Studio G62 Systems:

Once you enable Polycom Acoustic Fence, you must set up additional hardware to use this feature with your Poly Studio G62 system. You need a primary microphone and at least one more microphone to create the fence.

The boundary radius can be two to several feet around the following Poly peripheral devices:

- Table microphone

- Ceiling microphone

Note Microphones connected to a Poly Microphone IP Adapter currently don't support Polycom Acoustic Fence.

Once you set up the microphones, you can adjust the width of the audio fence beam to limit or expand where sounds are picked up inside the fence.

For information on setting up Polycom Acoustic Fence, see <https://docs.poly.com/bundle/video-room-prep-guide/page/specify-the-primary-and-fence-microphones.html>.

- [Configure Polycom Acoustic Fence](#)

You can enable and configure the Polycom Acoustic Fence feature to help define the audio fence around the system.

Configure Polycom Acoustic Fence

You can enable and configure the Polycom Acoustic Fence feature to help define the audio fence around the system.

Note This option isn't available if you enable Polycom StereoSurround.

Procedure

- 1 In the system web interface, go to **Audio/Video > Audio > General Audio Settings**.
- 2 Select the **Enable Acoustic Fence** check box.
- 3 Set **Acoustic Fence Sensitivity** to adjust the width of the audio fence beam.
 - **For Poly Studio G62 systems:** Higher values increase the width of the audio fence beam between the primary and fence microphone(s). Use 0 for the narrowest beam (+/- 10 degrees) or 10 for the widest beam (+/- 60 degrees).

Configure HDMI Audio Input

You can specify the audio input level for your system's HDMI connections (for example, audio from an HDMI-connected laptop).

Note When HDMI Input is set as People source, the HDMI audio is not captured or transmitted to the far side. If HDMI audio is required in this configuration, use another available input source such as USB or 3.5 mm.

Procedure

- 1 In the system web interface, go to **Audio/Video > Audio > Audio Input > HDMI**.
- 2 For **Audio Input Level**, set the left and right channel levels by choosing a value from 0 to 10.

The audio meters display the input's left and right channel levels.

Connect monitors to the Poly Studio G62 system

- [Configure Monitor Settings](#)

The system automatically detects the highest-supported setting for the connected monitor.

- [Connect a third monitor to a system in Zoom Rooms mode](#)

Poly Studio G62 and Poly Studio X52 support connecting a third monitor using the Pluggable USB to HDMI adapter (UGA-2KHDMI).

Connect two 4K monitors to the system to display far-side video and content.

Poly Studio G62 supports connecting two 4K monitors. However, support for 4K output depends on the supported output resolution of the provider you choose.

Note While video output can go to both monitors, audio output will only route to the monitor connected to HDMI 1 when you select **TV Speakers** as the output.

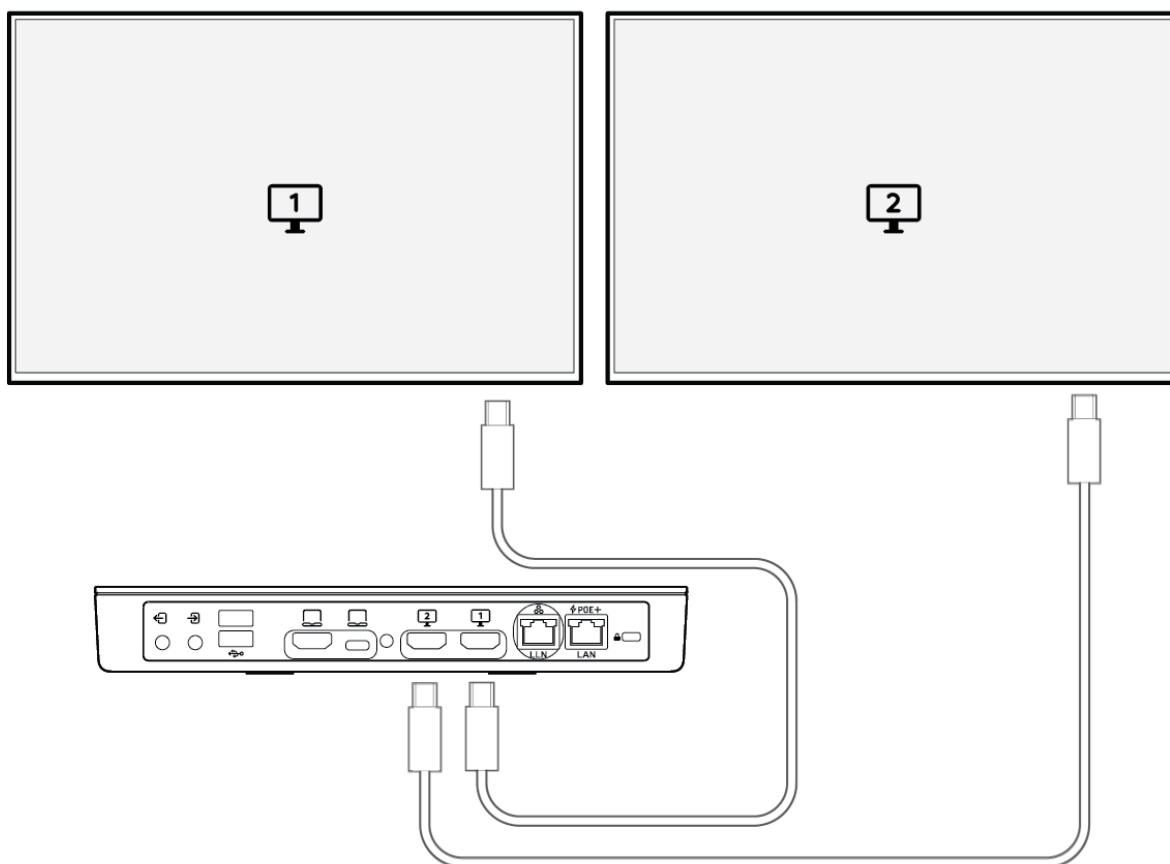

Procedure

- 1 Connect one end of the HDMI cable to HDMI port 1 on the primary monitor.
- 2 Connect the other end of the HDMI cable to the HDMI 1 port on the Poly Studio G62 system.
- 3 Connect a second monitor from the HDMI 1 port on the secondary monitor to the HDMI 2 port on the Poly Studio G62 system.

Configure Monitor Settings

- [Configure a Touch Monitor](#)

In a dual-monitor setup, where one or both are touch monitors, you must configure the touch monitors using the Poly Settings menu on the touch monitor.

- [Monitors with CEC](#)

You can use some Consumer Electronics Control (CEC) features with HDMI-connected monitors that support the CEC protocol.

The system automatically detects the highest-supported setting for the connected monitor.

Procedure

- 1 In the system web interface, go to **Audio/Video > Monitors**.
- 2 Configure the following settings (your changes save automatically):

Table 1. Monitor Settings

Setting	Description
Configure Monitor	<p>Specifies monitor settings.</p> <ul style="list-style-type: none">• Automatic: (Default) Detects the highest-supported resolution of the connected monitors.• Off: Disable this monitor (not available for Monitor 1).

Configure a Touch Monitor

In a dual-monitor setup, where one or both are touch monitors, you must configure the touch monitors using the Poly **Settings** menu on the touch monitor.

Note Touch monitors in single-monitor setups don't require configuration.

Procedure

- 1 On the touch monitor, do one of the following:
 - In a call: Go to **Menu** ≡ > **More** ⋮ > **Settings** ⚙ > **Diagnostics** > **Touch Configuration**.
 - Out of a call: Go to **Menu** ≡ > **Settings** ⚙ > **Diagnostics** > **Touch Configuration**.
- 2 On each screen, select the **Hand** icon.
- 3 Select **Finish Configuration**.

Monitors with CEC

You can use some Consumer Electronics Control (CEC) features with HDMI-connected monitors that support the CEC protocol.

Your system supports the following CEC commands:

- **One Touch Play:** You can wake connected monitors with your system remote control.

Remember the following when enabling CEC on your system:

- If you connect a monitor with an HDMI splitter, the splitter must support CEC. Due to HDMI splitter limitations, monitors behind a 1xM (one-input multiple-output) splitter might not switch to the correct input when waking up.
- The system doesn't respond to CEC commands from a monitor remote control.
- If a monitor is connected to two endpoints, the monitor displays the active endpoint when the other is sleeping.
- [Disable CEC](#)
Disable CEC in the system web interface.
- [Enable CEC](#)
Enable CEC in the system web interface.

Disable CEC

Disable CEC in the system web interface.

Procedure

- 1 In the system web interface, go to **Audio/Video** > **Monitors**.
- 2 Clear the **Enable Consumer Electronics Control** check box.

Enable CEC

Enable CEC in the system web interface.

Make sure your monitor's CEC settings are configured correctly (see your monitor's documentation).

Procedure

- 1 In the system web interface, go to **Audio/Video > Monitors**.
- 2 Select the **Enable Consumer Electronics Control** check box.

Connect a third monitor to a system in Zoom Rooms mode

Poly Studio G62 and Poly Studio X52 support connecting a third monitor using the Plugable USB to HDMI adapter (UGA-2KHDMI).

Note Connecting a third monitor is supported in Zoom Rooms mode only. Zoom Rooms output resolution to the third monitor is 1080p.

The Plugable USB to HDMI adapter (UGA-2KHDMI) is for connecting a third monitor only. You must have a primary and secondary monitor connected to HDMI Out port 1 and HDMI Out port 2 before connecting the adapter.

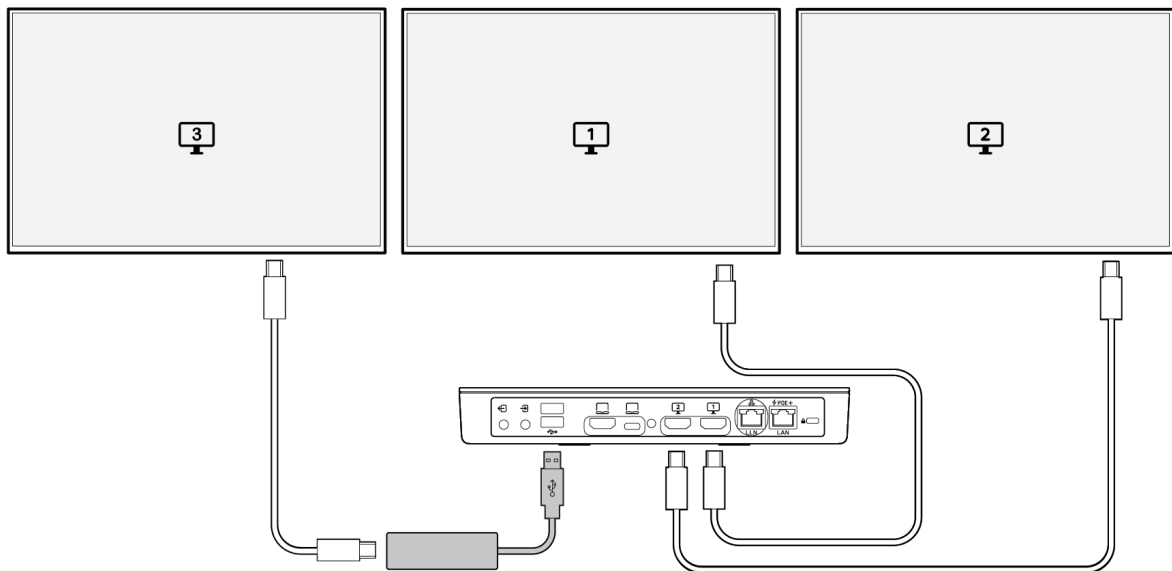

Procedure

- 1 Connect the Plugable USB to HDMI adapter (UGA-2KHDMI) to the USB Type-A port on the system.
- 2 Connect an HDMI cable from the HDMI 1 port on the third monitor to the Plugable USB to HDMI adapter.

The monitor is recognized by Zoom Rooms and content displays on the third monitor. Use the Zoom Rooms application to configure monitor layout.

Pairing Controllers to Poly Studio G62

Depending on the provider you choose, you can connect one or more supported system controllers.

Note	To power Poly TC10 and Poly TC8 touch controllers, connect the controller to a PoE Ethernet switch connected to your corporate network. Poly TC10 and Poly TC8 require internet access to download updates. Don't connect Poly TC10 or Poly TC8 to the Ethernet switch connected to the Poly Studio G62 LLN port.
-------------	--

You can choose from the following controller options:

- Poly TC10 or Poly TC8 touch controller—Supported by all providers
- Poly Bluetooth remote—Supported in Poly Video and Poly Device Mode
- Poly IR receiver and IR remote—Supported in Poly Video and Poly Device Mode
- Touch monitor—Supported in Poly Video and Poly Device Mode
- [Pair a Poly TC10 or Poly TC8 to your Poly Studio G62 system](#)
You can pair one or more Poly TC10 or Poly TC8 to your Poly Studio G62 system.
- [Connecting a room scheduler](#)
If you choose Microsoft Teams Rooms as a provider, you can configure a Poly TC10 as a room scheduler.

Pair a Poly TC10 or Poly TC8 to your Poly Studio G62 system

You can pair one or more Poly TC10 or Poly TC8 to your Poly Studio G62 system.

Procedure

- 1 Connect the Poly TC10 or Poly TC8 to a PoE Ethernet connection connected to your network.

You can't connect the Poly TC10 or Poly TC8 to an Ethernet switch connected to the Poly Studio G62 system LLN port.

- 2 At startup, use the out of box setup wizard to pair the Poly TC10 or Poly TC8 to your Poly Studio G62 system.

If you're setting up a new system, you can use the Poly TC10 or Poly TC8 to out of box the touch controller and the system at the same time.

Connecting a room scheduler

If you choose Microsoft Teams Rooms as a provider, you can configure a Poly TC10 as a room scheduler.

For information on setting up a Poly TC10 as a room scheduler, see the *Poly TC10 Administrator Guide* at <https://www.docs.poly.com>.

Content Sharing and Device Mode on Poly Studio G62

Use the Poly Studio G62 USB-C port or the HDMI in port to share content.

Note DP Alt mode on Poly Studio G62 only supports using the following cable:
USB Type-C 1.83 m (6 ft) part number L07087-002

To share content, you can:

- Connect an HDMI content source to the HDMI In port.
- Connect a computer Alt DP USB Type-C port to the USB Type-C port on the Poly Studio G62.
USB

If your computer doesn't support Alt DP, connect your computer to the USB Type-C and the HDMI In port on the Poly Studio G62.

- [Connect a computer to the system](#)

Use the system camera, microphones, speakers, and monitors from your computer.

- [Connect an HDMI content source to your Poly Studio G62](#)

You can connect an HDMI content source, such as a computer, to share content on your Poly Studio G62.

Connect a computer to the system

Use the system camera, microphones, speakers, and monitors from your computer.

Note DP Alt mode on Poly Studio G62 only supports using the following cable:
USB Type-C 1.83 m (6 ft) part number L07087-002

Procedure

- To use the system in Device Mode, do one of the following:

- Connect your computer to the USB Type-C port and the HDMI-In port on the Poly Studio G62 system. The USB Type-C and HDMI-In ports have a yellow label.
- Connect a computer USB Type-C port that supports DP Alt mode to the Poly Studio G62 USB Type-C port using the USB Type-C cable, part number L07087-002.

The system monitor and the Poly TC10 or Poly TC8 touch controller display a confirmation message.

If you're using Microsoft Teams, Device Mode automatically starts when you connect the USB cable to your computer. Once you disconnect the USB cable, the system automatically exits Device Mode in 20 to 30 seconds.

Connect an HDMI content source to your Poly Studio G62

You can connect an HDMI content source, such as a computer, to share content on your Poly Studio G62.

Procedure

- 1 Connect the HDMI content source to the HDMI input port on the Poly Studio G62.
- 2 Access the system web interface, and go to **Audio / Video > Video Inputs > HDMI input** and adjust settings including:

Table 1. Configurable settings for HDMI content input

Field	Type	Values
Display as	Drop-down list	Content (default)—Presents the HDMI input as content. The system indicates that content is available. People—Presents the HDMI input as a camera feed into the meeting.
Name	Drop-down list	Use this setting to help conference participants identify a camera to select during a call.

Field	Type	Values
Optimized for	Drop-down list	<p>Sharpness—Gives preference to resolution over frames per second.</p> <p>With this setting, moderate-to-heavy motion at low call rates can cause some frames to drop.</p> <p>Motion—Gives preference to frames per second over resolution.</p>
Enable HDMI Auto-Start	Checkbox	<p>Enable (default)</p> <p>Disable</p> <p>When enabled, content is immediately presented when an HDMI content source is connected to the system.</p>

Cable Requirements for Connecting Peripherals to Poly Studio G62

This section includes information about cables that can be used with a Poly Studio G62 system.

- [Cable requirements for network connectivity](#)
Use the following network cables with the Poly Studio G62 system.
- [Cable requirements for camera and monitor connectivity](#)
Use the following video and camera cables with the Poly Studio G62 system.
- [Cable requirements for audio connectivity](#)

Cable requirements for network connectivity

Use the following network cables with the Poly Studio G62 system.

Cable requirement for Poly Studio G62 power and network connectivity

Use a standards-based CAT5e, CAT6, or CAT7 direct Ethernet cable. The cable can be up to 91 m (300 ft) in length.

If you use a PoE+ class 4 power injector or PoE+ class 4 Ethernet switch, you'll need two Ethernet cables to power on and provide network connectivity for the Poly Studio G62.

Cable requirements for Poly Studio G62 IP LLN connectivity

Use a CAT5e, CAT6, or CAT7 direct Ethernet cable. The cable can be up to 91 m (300 ft) in length.

To connect multiple IP LLN devices to the Poly Studio G62 and provide power to the IP devices, use the Netgear ProAV M4250-9G1F-PoE+ (GSM4210PD) switch. To connect and power one device, you can use a PoE injector to provide power to Poly IP microphones or a Poly IP camera.

Cable requirements for Poly Studio G62 IP device connectivity

For other devices such as Poly TC10, Poly TC8, or Poly Trio C60, use the Ethernet cable provided with the device.

The power requirements for each device vary. See the product release notes and documentation for PoE power requirements.

Cable requirements for camera and monitor connectivity

Use the following video and camera cables with the Poly Studio G62 system.

HDMI monitor cable

Poly Studio G62 ships with one HDMI cable. To connect an additional monitor or a content source, you'll need additional HDMI cables. The system supports standards-based HDMI cables.

USB Type-C Alt-DP Mode cable

Use the following optional cable to connect a computer Alt DP USB Type-C port to the Studio G62 USB Type-C port. This is the only cable supported for Alt DP connectivity with the Poly Studio G62.

Table 1. USB-C to USB-C cable for Device Mode Display Port connectivity

Length	Part Number	Supplied
1.83 m (6 ft)	L07087-002	No

Cable requirements for connecting USB camera to Poly Studio G62e

Connect USB cameras to the Poly Studio G62 USB Type-A ports.

Use the cable that ships with the Poly Studio E70 camera. If you need to extend connectivity beyond the provided cable, see the camera release notes for supported extender options.

Cable requirements for audio connectivity

Cable requirements for Poly IP Table microphones

The Poly IP Table microphone ships with a CAT5e shielded cable.

Alternatively, you can use standards-based CAT5e, CAT6, or CAT7 direct Ethernet cable. The cable can be up to 91 m (300 ft) in length.

Length	Part Number	Supplied
25 ft (7.6 m) CAT 5E Shielded cable	2457-23216-002	Yes

Cable requirements for Poly IP Ceiling microphones

The Poly IP Ceiling microphone ships with multiple cables.

For IP LLN connectivity, you can use standards-based CAT5e, CAT6, or CAT7 direct Ethernet cable. The cable can be up to 91 m (300 ft) in length.

Length	Part Number	Supplied
Ethernet Plenum cable, 15.2 m / 50 ft)	2457-85361-001	Yes
Shielded CAT 5E cable, 2.1 m / 7 ft.	2457-17977-007	Yes
Cable assy 6-6 p mini XLR, CM4, 0.6 m / 2 ft	2457-85785-024	Yes

Cable requirements for 3.5 mm TRS connectivity

Poly Studio G62 supports 3.5 mm audio input and output. If your audio solution calls for connecting the Poly G62 using an analog 3.5 mm connection, refer to your A/V audio equipment manufacturers instructions for terminal block cabling. The typical maximum distance for 3.5 mm cables is 150 feet. However, this depends on the quality of cable you choose.

When connecting 3.5mm audio to your Poly Studio G62, make sure the 3.5mm connector is fully seated in the Poly Studio G62 3.5mm audio port.

Specifications for Poly Studio G62 and Peripherals

Review the product specifications for cable, power, and product dimensions.

- [Poly Studio G62 specifications](#)

Poly Studio G62 systems are suitable for medium to large-sized conference rooms.

- [Poly Studio E60 specifications](#)
Studio E60 cameras are suitable for large-sized conference rooms.
- [Poly Studio E70 specifications](#)
Poly Studio E70 cameras are suitable for large-sized conference rooms.
- [Poly EagleEye IV USB specifications](#)
Poly EagleEye IV USB cameras are suitable for large-sized conference rooms.

Poly Studio G62 specifications

Poly Studio G62 systems are suitable for medium to large-sized conference rooms.

Table 1. Poly Studio G62 Characteristics

Characteristic	Description
Physical	34.92 cm W × 3.81 cm H × 13.87 cm D (13.75 in. × 1.5 in × 5.5 in.) 0.95 kg (2.1 lbs)
Screen	Supplied HDMI cable (1) length: 1.8m (6 ft)
LAN connection	Supplied network cable length: 3m (9.8 ft)
Power	Powered using a PoE+ Class 4 port, injector, or switch. No power supply provided.
Power consumption	Typical operating voltage/power 100 to 240 VAC, 50/60 Hz 54V DC input, 3.34A, 180W Typical BTU/h: 65

Poly Studio E60 specifications

Studio E60 cameras are suitable for large-sized conference rooms.

Mounting options

You can mount your Studio E70 using one of the following options:

- Wall mount (above or below the monitor)
- Display clamp
- Ceiling mount
- Tripod mount

Table 1. Poly Studio E60 Power and Connectivity

Characteristic	Description
Physical	321 mm W x 102 mm H x 89.1 mm D (12.63 in x 4.02 in x 3.51 in) 907 g (2 lbs)
Power over Ethernet (PoE) connection	Supplied network cable length: 4.57 m (15 ft)
Power consumption	12VDC at 1.2A External power supply input spec: 100-240V 50/60Hz, 1.5A External power supply output spec: 12.0V DC, 5.0A, 60.0W, L.P.S

Table 2. Poly Studio E60 camera specifications

Specification	Value
Resolution	2160p, 4K UHD (3840 x 2160)
Range	10m (32.8 ft)
Zoom	12x optical zoom
Field of View	71°

For more specifications on this system, see the Product specifications page on the [HP support site](#).

Poly Studio E70 specifications

Poly Studio E70 cameras are suitable for large-sized conference rooms.

Mounting options

You can mount your Poly Studio E70 using one of the following options:

- Wall mount (above or below the monitor)
- Display mount

Table 1. Studio E70 Power and Connectivity

Characteristic	Description
Physical	321 mm W x 102 mm H x 89.1 mm D (12.63 in x 4.02 in x 3.51 in) 907 g (2 lbs)
Power over Ethernet (PoE) connection	Supplied network cable length: 4.57 m (15 ft)
Power consumption	12VDC at 1.2A External power supply input spec: 100-240V 50/60Hz, 1.5A External power supply output spec: 12.0V DC, 5.0A, 60.0W, L.P.S
Connection type	USB and IP LLN connectivity

Table 2. Poly Studio E70 camera specifications

Specification	Value
Resolution	2160p, 4K UHD (3840 x 2160)
Range	Up to 25ft

Specification	Value
Zoom	7.3x digital zoom
Field of View	120°; 70°

For more specifications on this system, see the Product specifications page on the [HP support site](#).

Poly EagleEye IV USB specifications

Poly EagleEye IV USB cameras are suitable for large-sized conference rooms.

You can mount your Poly EagleEye IV USB using one of the following options:

- Wall mount (above or below the monitor)

Table 1. Poly EagleEye IV USB Characteristics and Cable Lengths

Characteristic	Description
Physical	141.5 x 175.9 x 151.8 mm 907 g (2 lbs)
Power over Ethernet (PoE) connection	Supplied network cable length: 4.57 m (15 ft)
Power consumption	12VDC at 1.2A External power supply input spec: ??? External power supply output spec: 12v @ 1.5A power

Table 2. Poly EagleEye IV USB camera specifications

Specification	Value
Resolution	1080p, FHD (1920 x 1080)
Camera range	10 m (32.8 ft.)
Zoom	12x optical
Field of View	6.9° - 72.5° HFOV Pan range: +/- 170° Tilt range: +90° / -30°
Connection type	USB 2.0

For more specifications on this system, see the Product specifications page on the [HP support site](#).

Working with Poly Studio G62 command-line APIs

The command-line API lets you externally configure and control a Poly Studio G62 system. You can access the API with the following connections:

Note The command-line APIs work in Poly Video mode and have limited support in partner provider modes.

- SSH
- Telnet
- [Enable SSH access](#)
Use SSH on port 22 if you want encrypted access to the Poly Studio G62 system command-line API.
- [Access the command-line API over SSH](#)
You can use your Poly Studio G62 system local administrator credentials or external authentication to start an SSH session.
- [Enable telnet access](#)

Use port 24 or 23 to access the Poly Studio G62 system command-line API using telnet.

- [Access the command-line API over telnet](#)

From a device connected to the same LAN as your Poly Studio G62 system, you can access the command-line API using telnet (port 23 or 24 depending on how you've configured the system).

Enable SSH access

Use SSH on port 22 if you want encrypted access to the Poly Studio G62 system command-line API.

Procedure

- 1 In the web interface, go to **Security > Access**.
- 2 Select the **Enable Legacy API Over SSH** check box if it's cleared.

Access the command-line API over SSH

You can use your Poly Studio G62 system local administrator credentials or external authentication to start an SSH session.

For information on configuring system accounts, see the system *Administrator Guide* at the [Poly Online Support Center](#).

Procedure

- 1 Start an SSH session using the system IP address (for example, `ssh 10.x.x.x`).
- 2 When prompted, enter the system credentials.

Enable telnet access

Use port 24 or 23 to access the Poly Studio G62 system command-line API using telnet.

Procedure

- 1 In the web interface, go to **Security > Access**.
- 2 Select the **Enable Telnet Access** check box.
- 3 Choose an **API Port** for telnet connections: **24** (default) or **23**.

Access the command-line API over telnet

From a device connected to the same LAN as your Poly Studio G62 system, you can access the command-line API using telnet (port 23 or 24 depending on how you've configured the system).

Procedure

- 1 Start a telnet session using the system IP address and port number configured for the **API Port** setting (for example, telnet 10.xxx.xx.xx 24).
- 2 If prompted, log in with the system's local administrator password.

Command-line API reference for Poly Video Mode

The system command-line API is organized by category.

The command-line API is supported in Poly Video mode or Poly Device only. While some APIs may work in partner applications, using APIs with a partner application isn't supported.

Note While every attempt is made to ensure that the expected results of executing API commands are accurate, Poly cannot be responsible for system behaviors and control actions that are not explicitly documented.

- [About the command-line API](#)
Use the following guidelines to help you understand the command-line API.
- [Audio APIs](#)
- [Calendar APIs](#)
- [Calling APIs](#)
- [Camera APIs](#)
- [Directory and contacts APIs](#)
- [Content sharing APIs](#)
- [General APIs](#)
- [Network APIs](#)
- [Provisioning APIs](#)
- [Security APIs](#)
- [Security APIs](#)
- [System control and remote control APIs](#)
- [System settings APIs](#)
- [Video display APIs](#)

About the command-line API

Use the following guidelines to help you understand the command-line API.

- [Definitions](#)
The following definitions help you read the command-line API reference.
- [Syntax conventions](#)
The following conventions are used for the API command descriptions. Commands are case sensitive.
- [Command availability](#)
API command availability depends on the connected equipment, security settings, installed software version, among other factors.
- [Command response syntax](#)
When you send a command, the system returns responses using the syntax described in the following sections, where <CR> indicates a carriage return and <LF> indicates a line feed.
- [Commands that restart the system without a prompt](#)
The following API commands restart your system without notification:
- [Additional tips](#)
Refer to the following information when using the command-line API:

Definitions

The following definitions help you read the command-line API reference.

Table 1. Definitions

Terms	Description
Command Description	Brief statement about the purpose of the command.
Syntax	Format required to execute the command.
Parameter	A list of parameters defined for the command.
Description (parameter)	A description of each parameter that is defined for the command.
Feedback Examples	Examples of expected results when a command and variant are executed.

Terms	Description
Limitations	Important notes about support for the command on the system.
Comments	Important notes about the command.

Syntax conventions

The following conventions are used for the API command descriptions. Commands are case sensitive.

Table 1. Syntax conventions

Convention	Meaning
<param1 param2 param3>	Multiple valid parameters are enclosed in angle brackets and separated by the pipe (“ ”) character.
[param] [“param”]	Optional parameters are enclosed in square brackets. Quotation marks indicate string input.
{a..z}	A range of possible alphanumeric values is enclosed in braces.
“x”	Quotation marks indicate string input. You don’t need to enclose the value in quotes unless it contains a space.

Although the command-line API parser may accept the minimum number of characters in a command that makes it unique, you should always use the full command string.

Command availability

API command availability depends on the connected equipment, security settings, installed software version, among other factors.

If a particular command isn’t supported, the command returns feedback such as, “command is not available in current system configuration”.

If a setting is configured by a provisioning service, the command may return, “this setting is controlled by a provisioning service and cannot be changed. For more information about provisioned settings, refer to your provisioning service administrator.”

Commands that are not listed are not supported by Poly. Commands might change or be removed at any time. Poly discourages integrators from using unpublished commands.

Command response syntax

When you send a command, the system returns responses using the syntax described in the following sections, where <CR> indicates a carriage return and <LF> indicates a line feed.

Unregistered for notifications

When your system is not registered to receive notifications and you send an API command, a single API acknowledgment is returned.

For example:

```
camera near 1<CR> API command
```

returns

```
camera near 1<CR><LF> API acknowledgment
```

In the previous example, the command was sent with a carriage return <CR>.

The API expects a carriage return <CR> and the standard end of line characters carriage return/line feed <CR><LF>. All API responses end in carriage return/line feed <CR><LF>.

Registered for notifications

Registering for notifications adds extra line responses. The number of additional lines depends on the specific registration. In the following example, the response shows an API acknowledgment and registration response returned:

```
camera near 1 <CR> API command
```

returns

```
camera near 1<CR><LF> API acknowledgment
```

```
notification:vidsourcechange:near:1:Main:people<CR><LF>
```

API registration response

When your system is registered for notifications, always use the API registration response for status.

Commands that restart the system without a prompt

The following API commands restart your system without notification:

- rebootnow
- resetsettings

Additional tips

Refer to the following information when using the command-line API:

- The system doesn't provide flow control.
- If you lose an API connection (for example, the system restarts), you must re-establish it.
- The API processes one command at a time.
- Poly doesn't recommend sending multiple commands simultaneously without a pause or delay between each.
- For commands with a single action and response: A delay of 200 milliseconds between commands is sufficient. Examples of these commands include the commands for switching cameras (camera near 1), sending content (vcbutton play), and checking the status of audio mute (mute near get).
- For commands with a single action and a more extensive response: The time it takes to receive the response (and in effect the time between commands) may be longer than 200 milliseconds. The response length, which can vary, determines the time required to receive the response. Examples include the commands for retrieving directory information (such as addrbook all) and system session information (such as whoami).
- When developing your application, always allow enough time for a command response before sending another command.
- Poly doesn't recommend sending commands while a call is being established.
- The API provides feedback status in two ways: registrations or polling.
- Send registration and notification API commands only once. Registrations are written to flash memory and retained when the system restarts.
- Poly recommends putting registrations in the initialization or startup of Crestron and AMX systems.
- Registrations are recommended over polling since they provide status updates without having to query for changes.
- Never poll for registrations.
- Registrations are specific to the port from which they're registered. If you register for notifications from com port 1, registration will not be sent to com port 2 or telnet port 24.

Audio APIs

- [audio3p5inputfaronly](#)

Gets or sets the preference for 3.5mm audio input from the system's 3.5mm audio port.

- [audiotransmitlevel](#)

Sets or gets the audio volume transmitted to the far site. Also register for notifications of audio transmit level changes.

- [echocanceller](#)

Gets and sets the configuration of line-input port echo cancellation that prevents users from hearing their voices loop back from the far site.

- [enableacousticfence](#)

Gets or sets the current setting for the Polycom® Acoustic Fence™ technology feature.

- [enableaudioadd](#)

Enables or disables the Audio Add In feature, which allows one additional outbound, audio-only call from a system when the maximum number of calls allowed for a license is reached.

- [enablekeyboardnoisereduction](#)

Gets or sets the keyboard noise reduction feature.

- [enablelivemusicmode](#)

Gets or sets the M-Mode feature.

audio3p5inputfaronly

Gets or sets the preference for 3.5mm audio input from the system's 3.5mm audio port.

Syntax

```
audio3p5inputfaronly <get|enable|disable>
```

Table 1.

Parameter	Description
get	Returns the current settings.
enable	3.5 mm audio input is sent only to the far site.
disable	3.5 mm audio input is sent to both far and near sites.

Feedback examples

- `audio3p5inputfaronly get`
returns

```
audio3p5inputfaronly enable
```

- ```
audio3p5inputfaronly disable
```

 returns 

```
audio3p5inputfaronly disable
```

Limitations

None

Comments

None

## ***audiotransmitlevel***

Sets or gets the audio volume transmitted to the far site. Also register for notifications of audio transmit level changes.

Syntax

```
audiotransmitlevel <get|up|down|register|unregister>
audiotransmitlevel set {-6..18}
```

Table 1.

| Parameter  | Description                                                            |
|------------|------------------------------------------------------------------------|
| get        | Returns the current setting.                                           |
| up         | Sets the volume 1 decibel higher than the current setting.             |
| down       | Sets the volume 1 decibel lower than the current setting.              |
| register   | Registers to receive notification when audio transmit level changes.   |
| unregister | Unregisters to receive notification when audio transmit level changes. |

| Parameter | Description                                                            |
|-----------|------------------------------------------------------------------------|
| set       | Sets the volume to the specified dB level. Valid values are: {-6..18}. |

#### Feedback examples

- `audiotransmitlevel set 2`  
returns  
`audiotransmitlevel 2`
- `audiotransmitlevel get`  
returns  
`audiotransmitlevel 2`
- `audiotransmitlevel up`  
returns  
`audiotransmitlevel 3`
- `audiotransmitlevel down`  
returns  
`audiotransmitlevel 2`
- `audiotransmitlevel register`  
returns  
`audiotransmitlevel registered`
- `audiotransmitlevel unregister`  
returns  
`audiotransmitlevel unregistered`

#### Limitations

None

#### Comments

None

## ***echocanceller***

Gets and sets the configuration of line-input port echo cancellation that prevents users from hearing their voices loop back from the far site.

## Syntax

```
echocanceller <get|yes|no>
```

Table 1.

| Parameter | Description                         |
|-----------|-------------------------------------|
| get       | Returns the current setting.        |
| yes       | Enables the echo canceller option.  |
| no        | Disables the echo canceller option. |

## Feedback Examples

- echocanceller get  
returns  
echocanceller no

## Limitations

None

## Comments

None

## ***enableacousticfence***

Gets or sets the current setting for the Polycom® Acoustic Fence™ technology feature.

## Syntax

```
enableacousticfence <get|on|off>
```



Table 1.

| Parameter | Description                      |
|-----------|----------------------------------|
| get       | Returns the current setting.     |
| on        | Enables Polycom Acoustic Fence.  |
| off       | Disables Polycom Acoustic Fence. |

#### Feedback Examples

- enableacousticfence get  
returns  
enableacousticfence on
- enableacousticfence on  
returns  
enableacousticfence on
- enableacousticfence off  
returns  
enableacousticfence off

#### Limitations

None

#### Comments

None

### **enableaudioadd**

Enables or disables the Audio Add In feature, which allows one additional outbound, audio-only call from a system when the maximum number of calls allowed for a license is reached.

#### Syntax

```
enableaudioadd <get|yes|no>
```

Table 1.

| Parameter | Description                                                     |
|-----------|-----------------------------------------------------------------|
| get       | Returns the current setting.                                    |
| yes       | Enables the Audio Add-In features. This is the default setting. |
| no        | Disables the Audio Add-In feature.                              |

#### Feedback Examples

- enableaudioadd get  
returns  
enableaudioadd yes
- enableaudioadd yes  
returns  
enableaudioadd yes
- enableaudioadd no  
returns  
enableaudioadd no

#### Limitations

None

#### Comments

None

### ***enablekeyboardnoisereduction***

Gets or sets the keyboard noise reduction feature.

#### Syntax

```
enablekeyboardnoisereduction <get|yes|no>
```

Table 1.

| Parameter | Description                        |
|-----------|------------------------------------|
| get       | Returns the current setting.       |
| yes       | Enables keyboard noise reduction.  |
| no        | Disables keyboard noise reduction. |

#### Feedback Examples

- enablekeyboardnoisereduction yes  
returns  
enablekeyboardnoisereduction yes
- enablekeyboardnoisereduction no  
returns  
enablekeyboardnoisereduction no
- enablekeyboardnoisereduction get  
returns  
enablekeyboardnoisereduction no

#### Limitations

None

#### Comments

None

### ***enablelivemusicmode***

Gets or sets the M-Mode feature.

#### Syntax

```
enablelivemusicmode <get|yes|no>
```

Table 1.

| Parameter | Description                  |
|-----------|------------------------------|
| get       | Returns the current setting. |
| yes       | Enables M-Mode.              |
| no        | Disables M-Mode.             |

#### Feedback Examples

- enablelivemusicmode yes  
returns  
enablelivemusicmode yes
- enablelivemusicmode no  
returns  
enablelivemusicmode no

#### Limitations

None

#### Comments

M-Mode was previously known as MusicMode. The feature functions the same way as before despite the name change.

## **Calendar APIs**

- [calendardiscovery](#)  
Gets the Microsoft Exchange Server address based on the associated email address or registered SIP server address configured for the system.
- [calendardomain](#)  
Gets or sets the domain used by the calendaring service to log in to the Microsoft Exchange Server.
- [calendarmeetings](#)  
Retrieves scheduled meetings within a provided time or for a meeting ID.
- [calendarpassword](#)

Sets the password used by the calendaring service to log in to the Microsoft Exchange Server.

- [calendarplaytone](#)

Gets or sets the reminder alert tone that plays with the meeting reminder when the system is registered with the calendaring service.

- [calendarprotocol](#)

Gets or sets the protocol to use when connecting to the calendaring service.

- [calendarregisterwithserver](#)

Enables or disables the calendaring service.

- [calendarremindertime](#)

Gets or sets the meeting reminder time when the system is registered with the calendaring service.

- [calendarresource](#)

Gets or sets the resource (i.e., account) monitored for calendar events.

- [calendarserver](#)

Gets or sets the Microsoft Exchange Server used by the calendaring service.

- [calendarshowpvtmeetings](#)

Enables or disables the display of private meetings in the calendar when the system is registered with the calendaring service.

- [calendarstatus](#)

Returns the status of the Microsoft Exchange Server connection.

- [calendaruser](#)

Gets or sets the user name the calendaring service uses to log in to the Microsoft Exchange Server.

## ***calendardiscovery***

Gets the Microsoft Exchange Server address based on the associated email address or registered SIP server address configured for the system.

### Syntax

```
calendardiscovery get
calendardiscovery emaildomain
calendardiscovery sipdomain
```

Table 1.

| Parameter   | Description                                                                                                   |
|-------------|---------------------------------------------------------------------------------------------------------------|
| get         | Gets the Microsoft Exchange Server address that the system is using to register with the calendaring service. |
| emaildomain | Gets the Microsoft Exchange Server address based on an email address.                                         |
| sipdomain   | Gets the Microsoft Exchange Server address based on a SIP server address.                                     |

#### Feedback examples

- `calendardiscovery sipdomain get`  
returns  
`calendardiscovery 192.168.44.168`
- `calendardiscovery emaildomain get`  
returns  
`calendardiscovery mail.exchangeserver.local.com`
- `calendardiscovery get`  
returns  
`calendardiscovery not available (if not configured or not found)`
- `calendardiscovery emaildomain get`  
returns  
`calendardiscovery not available (if not configured or not found)`
- `calendardiscovery get`  
returns  
`error: command needs more parameters to execute successfully`
- `calendardiscovery`  
returns  
`error: command needs more parameters to execute successfully`

#### Limitations

None

Comments

None

## ***calendardomain***

Gets or sets the domain used by the calendaring service to log in to the Microsoft Exchange Server.

Syntax

```
calendardomain get
calendardomain set "domain"
```

Table 1.

| Parameter | Description                                                                  |
|-----------|------------------------------------------------------------------------------|
| get       | Returns the domain used by the calendaring service.                          |
| set       | Sets the domain used by the calendaring service.                             |
| "domain"  | Specifies the domain for the calendaring service when using the set command. |

Feedback examples

- calendardomain get  
returns  
calendardomain smithfield
- calendardomain set fairview  
returns  
calendardomain fairview

Limitations

None

Comments

None

## ***calendarmeetings***

Retrieves scheduled meetings within a provided time or for a meeting ID.

Syntax

```
calendarmeetings list "starttime" ["endtime"]
calendarmeetings info "meetingid"
```

Table 1.

| Parameter   | Description                                                                                                                                                                                                                                                                                                                                                        |
|-------------|--------------------------------------------------------------------------------------------------------------------------------------------------------------------------------------------------------------------------------------------------------------------------------------------------------------------------------------------------------------------|
| list        | Returns the meeting id or ids for meetings that start at or after the specified start time and end time.                                                                                                                                                                                                                                                           |
| "starttime" | The start time of meetings to be retrieved.<br><br>The start time can be entered in one of the following formats: <ul style="list-style-type: none"><li>● YYYY-MM-DD:HH:MM</li><li>● today:HH:MM</li><li>● today</li><li>● tomorrow:HH:MM</li><li>● tomorrow</li></ul> The times are interpreted to be local times in the time zone the system was configured for. |



| Parameter   | Description                                                                                                                                                                                                                                                                                                                                                                |
|-------------|----------------------------------------------------------------------------------------------------------------------------------------------------------------------------------------------------------------------------------------------------------------------------------------------------------------------------------------------------------------------------|
| "endtime"   | <p>The end time of meetings to be retrieved.</p> <p>This parameter can be given in the following format.</p> <ul style="list-style-type: none"> <li>● YYYY-MM-DD:HH:MM</li> <li>● today:HH:MM</li> <li>● today</li> <li>● tomorrow:HH:MM</li> <li>● tomorrow</li> </ul> <p>The times are interpreted to be local times in the time zone the system was configured for.</p> |
| info        | <p>Retrieves meeting details for scheduled meetings when the system is registered with the calendaring service. Returns information such as the location, subject and organizer of the meeting.</p>                                                                                                                                                                        |
| "meetingid" | <p>The ID of the meeting for which you want to find details.</p>                                                                                                                                                                                                                                                                                                           |

#### Feedback examples

- `calendarmeetings list tomorrow`  
returns  
`calendarmeetings list begin meeting|AAAaAEFsZXguTWFjRG9uYWxkQHBvbH1jb20uY29tAVEAC`  
`meeting|AAAaAEFsZXguTWFjRG9uYWxkQHBvbH1jb20uY29tAVEACIjMne2/ndgARgAAAADr9 G1hsSjW`  
`LKAAAA/9PhAAAQ|2010-03-30:09:00|2010-03-30:09:30|Program Review`  
`meeting|AAAaAEFsZXguTWFjRG9uYWxkQHBvbH1jb20uY29tAVEACIjMne2/ndgARgAAAADr9 G1hsSjW`  
`calendarmeetings list end`
- `calendarmeetings list 2010-03-30:08:00 2010-04-01:17:00`  
returns  
`calendarmeetings list begin meeting|AAAaAEFsZXguTWFjRG9uYWxkQHBvbH1jb20uY29tAVEAC`  
`meeting|AAAaAEFsZXguTWFjRG9uYWxkQHBvbH1jb20uY29tAVEACIjMne2/ndgARgAAAADr9 G1hsSjW`  
`reference Coordination meeting|AAAaAEFsZXguTWFjRG9uYWxkQHBvbH1jb20uY29tAVEACIjMne2/ndgARgAAAADr9 G1hsSjW`  
`calendarmeetings list end`

- `calendarmeetings info`  
`AAAaAEFsZXguTWFjRG9uYWxkQHBvbH1jb20uY29tAVEACIjMne2/`  
`ndgARgAAAADr9G1hsSjWE`  
`ZBcAAKzMphJBwA4wicbtr3UEZArAKAk09LtAAACZpKWAADe7hJ1eQIOS7j2mzRJxkLKAAADI/`  
`G8AAAQ`

`returns`

```
calendarmeetings info start id|AAAaAEFsZXguTWFjRG9uYWxkQHBvbH1jb20uY29tAVEACIjMne2/
2010-03-30:08:30|2010-03-30:09:00|dialable|public organizer|Russell Bell
location|Russell's Meeting Room - IP Video Number: 123456 (if registered to corp
dialingnumber|audio|48527 meetingpassword|none attendee|Russell Bell attendee|Rebecca Sharp
```

- `calendarmeetings info`  
`AAAaAEFsZXguTWFjRG9uYWxkQHBvbH1jb20uY29tAVEACIjMn4AUcVgARgAAAADr9G1hsSjWE`  
`ZBcAAKzMphJBwA4wicbtr3UEZArAKAk09LtAAACZpKWAADe7hJ1eQIOS7j2mzRJxkLKAAA30`  
`GwAAAQ`

`returns`

```
calendarmeetings info start id|AAAaAEFsZXguTWFjRG9uYWxkQHBvbH1jb20uY29tAVEACIjMn4AUcVgARgAAAADr9G1hsSjWE
2010-04-01:10:30|2010-04-01:11:00|nondialable|private organizer|Rebecca Sharp
location|Red River conference room subject|Escalations Review attendee|Roslin Adams
```

#### Limitations

None

#### Comments

If the meeting's end time is more than 31 days from the meeting's start time, the response is shortened to

`start time+31days`, and meetings that start in that time span are returned.

If an API client is logged in with user-level credentials and if the system is configured to hide private meeting information on the web interface, the API hides the information from the API client and shows the subject of the meeting as "Private Meeting", for example:

```
calendarmeetings list begin
meeting|AAAaAEFsZXguTWFjRG9uYWxkQHBvbH1jb20uY29tAVEACIjMn4AUcVgARgAAAADr9G1hsSjWEZBcAAKzMphJBwA4wicbtr3UEZArAKAk09LtAAACZpKWAADe7hJ1eQIOS7j2mzRJxkLKAAA30GwAAAQ
calendarmeetings list end
```

If a system is configured to provide private meeting information on the web interface, the API provides the same information to the API client, for example:

```
calendarmeetings list begin
meeting|AAAZAGV4Y2H1C2VYMDFACJEZLNZZZY5SB2NHBDIARGAAAAAAKQKC8WWW3CUWGCPM+AP66WQ CASOLXU
calendarmeetings list end
```

If the API client is logged in with admin-level credentials, the API provides private meeting information to the API client, regardless of the configuration for displaying private meeting information, for example:

```
calendarmeetings list begin
meeting|AAAZAGV4Y2H1C2VYMDFACJEZLNZZZY5SB2NHBDIARGAAAAAAKQKC8WWW3CUWGCPM+AP66WQ CASOLXU
8:30|2009-09-25:09:15|Release plan
meeting|AAAZAGV4Y2H1C2VYMDFACJEZLNZZZY5SB2NHBDIARGAAAAAAKQKC8WWW3CUWGCPM+AP66WQ CASOLXU
```

1:00|2009-09-23:11:45|Product roadmap for 2010  
calendarmeetings list end

The calendaring service must be registered with Microsoft Exchange Server for the calendarmeetings command to work successfully. If the calendar credentials are invalid, the server address is not valid, or the configured user credentials don't have access permissions to the resource mailbox calendar, the service will fail to register.

This command has multiline output.

The following characters in the meeting subject will not be displayed:

- | (vertical bar)
- CR (carriage return)
- LF (line feed)

See also

To enable or disable the calendaring service, use the [calendarregisterwithserver](#) command.

To configure the Microsoft Exchange Server address that is used by this service, use the [calendarserver](#) command.

## ***calendarpassword***

Sets the password used by the calendaring service to log in to the Microsoft Exchange Server.

Syntax

```
calendarpassword "password"
```

Table 1.

| Parameter  | Description                                                                              |
|------------|------------------------------------------------------------------------------------------|
| "password" | The password used by the calendaring service to log in to the Microsoft Exchange Server. |

Feedback examples

- ```
calendarpassword Dscalendar
```

 returns

```
calendarpassword Dscalendar
```

Limitations

None

Comments

The password is case-sensitive and can contain a maximum of 15 characters. Use strong passwords that combine uppercase and lowercase letters, numbers, and symbols.

calendarplaytone

Gets or sets the reminder alert tone that plays with the meeting reminder when the system is registered with the calendaring service.

Syntax

```
calendarplaytone get  
calendarplaytone <yes|no>
```

Table 1.

Parameter	Description
get	Gets the current setting for the alert tone.
yes	Enables the alert tone.
no	Disables the alert tone.

Feedback examples

- `calendarplaytone get`
returns
`calendarplaytone yes`
- `calendarplaytone yes`
returns
`calendarplaytone yes`
- `calendarplaytone no`
returns
`calendarplaytone no`

Limitations

None

Comments

None

calendarprotocol

Gets or sets the protocol to use when connecting to the calendaring service.

Syntax

`calendarprotocol <get|auto|tls>`

Table 1.

Parameter	Description
get	Gets the current setting.
auto	Sets the connection protocol to automatic discovery.
tls	Sets the connection protocol to TLS.

Feedback examples

- `calendarprotocol get`
returns
`calendarprotocol tls`
- `calendarprotocol auto`
returns
`calendarprotocol auto`

Limitations

None

Comments

None

calendarregisterwithserver

Enables or disables the calendaring service.

Syntax

```
calendarregisterwithserver get  
calendarregisterwithserver <yes|no>
```

Table 1.

Parameter	Description
get	Returns the current server registration status.
yes	Enables the calendaring service.
no	Disables the calendaring service.

Feedback examples

- `calendarregisterwithserver get`
returns
`calendarregisterwithserver no`
- `calendarregisterwithserver yes`
returns
`calendarregisterwithserver yes`
- `calendarregisterwithserver no`
returns
`calendarregisterwithserver no`

Limitations

None

Comments

To configure the Microsoft Exchange Server address used by the calendaring service, use the `calendarserver` command.

calendarremindertime

Gets or sets the meeting reminder time when the system is registered with the calendaring service.

Syntax

calendarremindertime <get|1|5|10|15|30|none>

Table 1.

Parameter	Description
get	Gets the current reminder time.
1 5 10 15 30 none	The number of minutes before a meeting starts that a meeting reminder is given. The default is 5.

Feedback examples

- calendarremindertime get
returns
calendarremindertime 5
- calendarremindertime 15
returns
calendarremindertime 15
- calendarremindertime none
returns
calendarremindertime none

Limitations

None

Comments

None

See also

Use the [notify](#) command to register for meeting reminders.

See also [calendarplaytone](#) command.

calendarresource

Gets or sets the resource (i.e., account) monitored for calendar events.

Syntax

```
calendarresource get
calendarresource "resource"
```

Table 1.

Parameter	Description
get	Returns the resource monitored for calendar events.
"resource"	The resource to monitor for calendaring events.

Feedback examples

- `calendarresource get`
returns
`calendarresource radam@abcde.com`
- `calendarresource jmcnulty@abcde.com`
returns
`calendarresource jmcnulty@abcde.com`

Limitations

None

Comments

A resource can be a user or resource account. A resource account is assigned to a meeting room.

See also

Use the [calendarregisterwithserver](#) command to enable or disable the calendaring service. See the [calendarserver](#) command to configure the Microsoft Exchange Server address used by the calendaring service.

calendarserver

Gets or sets the Microsoft Exchange Server used by the calendaring service.

Syntax

```
calendarserver get
calendarserver "server"
```

Table 1.

Parameter	Description
get	Gets the current Microsoft Exchange Server used by the calendaring service.
“server”	The IP address or DNS name of the Microsoft Exchange Server used by the calendaring service.

Feedback examples

- `calendarserver get`
returns
`calendarserver 192.168.44.168`
- `calendarserver 192.168.23.221`
returns
`calendarserver 192.168.23.221`
- `calendarserver get`
returns
`calendarserver mail.exchangeserver.local.com`
- `calendarserver mail2.exchserver.local.com`
returns
`calendarserver mail2.exchserver.local.com`

Limitations

None

Comments

None

See also

Use the [calendarregisterwithserver](#) command to enable or disable the calendaring service.

calendarshowpvtmeetings

Enables or disables the display of private meetings in the calendar when the system is registered with the calendaring service.

Syntax

```
calendarshowpvtmeetings get  
calendarshowpvtmeetings <yes|no>
```

Table 1.

Parameter	Description
get	Gets the current setting for private meeting display.
yes	Enables the display of private meetings.
no	Blocks the display of private meetings.

Feedback examples

- `calendarshowpvtmeetings get`
returns
`calendarshowpvtmeetings no`
- `calendarshowpvtmeetings yes`
returns
`calendarshowpvtmeetings yes`
- `calendarshowpvtmeetings no`
returns
`calendarshowpvtmeetings no`

Limitations

None

Comments

None

See also

Use the `calendarregisterwithserver` command to enable or disable the calendaring service.

calendarstatus

Returns the status of the Microsoft Exchange Server connection.

Syntax

```
calendarstatus get
```

Table 1.

Parameter	Description
get	Returns the Microsoft Exchange Server connection status.

Feedback Examples

- `calendarstatus get`
returns
`calendarstatus established`
- `calendarstatus get`
returns
`calendarstatus unavailable`

Limitations

None

Comments

None

See also

Use the [calendarregisterwithserver](#) command to enable or disable the calendaring service.

calendaruser

Gets or sets the user name the calendaring service uses to log in to the Microsoft Exchange Server.

Syntax

```
calendaruser get  
calendaruser "username"
```

Table 1.

Parameter	Description
get	Returns the user name being used by the calendaring service.
username	The user name the calendaring service uses to log in to the Microsoft Exchange Server.

Feedback examples

- `calendaruser get`
returns
`calendaruser jpolycom`

Limitations

None

Comments

None

See also

See the [calendarserver](#) command to configure the Microsoft Exchange Server address used by this service.

Calling APIs

- [callinfo](#)
Returns information about the current call.
- [callstate](#)
Sets or gets the call state notification for call state events.
- [autoanswer](#)
Sets how the system handles incoming point-to-point calls.
- [answer](#)
Answers incoming video calls.
- [dial](#)
Dials video or audio calls manually or from the directory.
- [gential](#)

Generates DTMF dialing tones.

- [gendialset](#)

Audible dual-tone multi-frequency (DTMF) tones are disabled when making a call on a Poly G7500 system using a connected Poly Group Series device in Poly Video mode.

- [generatetone](#)

Turns the test tone on or off. The tone is used to check the monitor audio cable connections or to monitor the volume level.

- [getcallstate](#)

Gets the state of the calls in the current conference.

- [hangup](#)

Hangs up the video call.

- [maxtimeincall](#)

Gets or sets the maximum number of minutes allowed for call length.

- [mute](#)

Gets or sets near- or far-site mute settings.

- [muteautoanswer](#)

Gets or sets if the audio is muted for auto-answered calls. When this is on, your microphone is muted to prevent the far site from immediately hearing the near site.

- [volume](#)

Gets or sets the call audio volume (not sound effects) on the system or registration for volume changes. Changes the call audio volume (not sound effects) on the system.

- [recentcalls](#)

Returns a list of recent calls.

- [videomute](#)

Gets or sets the transmission of local video to the far site.

- [videocallorder](#)

Gets or sets the video call order of the specified protocol to the specified slot.

callinfo

Returns information about the current call.

Syntax

```
callinfo all  
callinfo callid "callid"
```

Table 1.

Parameter	Description
all	Returns information about each connection in the call.
callid	Returns information about the connection with the specified call ID.

Feedback examples

- `callinfo callid 36`
returns
`callinfo:36:192.168.1.102:256:connected:muted:outgoing:videocall`
- `callinfo all`
returns
`system is not in a call`
when no call is currently connected

Limitations

None

Comments

The `callid` information is returned using the following format:

```
callinfo:<callid>:<far site name>:<far site number>:<speed>:  
<connection status>:<mute status>:<call direction>:<call type>
```

callstate

Sets or gets the call state notification for call state events.

Syntax

```
callstate <get|register|unregister>
```

Table 1.

Parameter	Description
get	Returns the current setting.
register	Registers the system to give notification of call activities.
unregister	Disables the register mode.

Feedback Examples

- `callstate register`
returns
`callstate registered`
- `callstate unregister`
returns
`callstate unregistered`
- `callstate get`
returns
`callstate unregistered`

After registering, the following callstate (cs:) data is returned when connecting an IP call:

```
cs: call[34] chan[0] dialstr[192.168.1.103] state[ALLOCATED]
cs: call[34] chan[0] dialstr[192.168.1.103] state[RINGING]
cs: call[34] chan[0] dialstr[192.168.1.103] state[COMPLETE]
active: call[34] speed [384]
```

After registering, the following response occurs when disconnecting an IP call:

```
cleared: call[34]
dialstr[IP:192.168.1.103 NAME:Polycom Demo]
ended: call[34]
```

Limitations

None

Comments

To retrieve call state status, Poly recommends using `notify callstatus` instead of `callstate register`.

If you use callstate register, don't also use notify callstatus.

See also

You can also use the [notify](#) command and the [nonotify](#) command for notifications.

autoanswer

Sets how the system handles incoming point-to-point calls.

Syntax

```
autoanswer <get|yes|no|donotdisturb>
```

Table 1.

Parameter	Description
get	Returns the current setting.
yes	Incoming calls are connected automatically. This is the default setting.
no	Prompts the user to answer incoming calls.
donotdisturb	Notifies the user of incoming calls but does not connect. The far side receives a rejected call notification.

Feedback examples

- autoanswer yes
returns
autoanswer yes
- autoanswer no
returns
autoanswer no
- autoanswer get
returns
autoanswer no

- `autoanswer donotdisturb`
returns
`autoanswer donotdisturb`

Limitations

None

Comments

If `autoanswer` is set to `no` or `donotdisturb`, you must rely on API session notifications to answer inbound calls.

answer

Answers incoming video calls.

Syntax

`answer <video>`

Table 1.

Parameter	Description
<code>video</code>	Answers incoming video calls when Auto Answer Point-to-Point Video or Auto Answer Multipoint Video is set to No.

Feedback examples

- `answer video`
returns
`answer incoming video call failed`
- `answer video`
returns
`answer incoming video call passed`

Limitations

None

Comments

None

dial

Dials video or audio calls manually or from the directory.

Syntax

```
dial addressbook "addr book name"  
dial auto "speed" "dialstr"  
dial manual "speed" "dialstr1" ["dialstr2"] [h323|ip|sip]  
dial phone <sip|h323|auto> "dialstring"
```

Table 1.

Parameter	Description
addressbook	Dials a directory (address book) entry. Requires the name of the entry.
"addrbook name"	The name of the directory (address book) entry. The name may be up to 25 characters. Use quotation marks around strings that contain spaces. For example: "John Doe".
auto	Automatically dials a number. When used with "speed" and "dialstr", dials a video call number dialstr1 at speed of type h323.
"speed"	Valid data rate for the network.
"dialstr", "dialstr1", "dialstr2"	IP directory number.
manual	Dials a video call number dialstr1 at speed of type h323. Requires the parameters "speed" and "dialstr1". Use dialmanual "speed" "dialstr" "type" when you do not want automatic call rollover or when the dial string might not convey the intended transport. Use dial manual without specifying a call type

Parameter	Description
h323 ip sip	Call type
phone	Dials an audio call. This option is supported only when the Enable Audio Add In call feature is enabled.
"dialstring"	Numeric string specifying the phone number to dial. Enclose the string in quotation marks if it includes spaces. Example: "512 555 1212"

Feedback Examples

- If registered for callstate notifications (callstate register) returns

```
cs: call[44] chan[0] dialstr[5551212] state[ALLOCATED] cs: call[44]
chan[0] dialstr[5551212] state[RINGING] cs: call[44] chan[0]
dialstr[5551212] state[CONNECTED] cs: call[44] chan[0]
dialstr[5551212] state[CONNECTED] cs: call[44] chan[0]
dialstr[5551212] state[COMPLETE] cs: call[44] chan[0] dialstr[5551212]
state[COMPLETE] active: call[44] speed[64]
```
- dial addressbook "John Polycom" returns
dialing addressbook "John Polycom"
- dial phone sip 1234 returns
dialing voice_sip
- If SIP is not enabled dial phone sip 1234 returns
info: IP line (SIP) not enabled.

Note The [BONDING] responses in IP calls are extraneous text that will be removed in a subsequent software version.

Call ID (call [44]) is an example of the response. The Call ID number depends upon the call type.

- If registered for callstatus notifications (notify callstatus) returns

```
notification:callstatus:outgoing:45:null 1::opened::0:videocall
notification:callstatus:outgoing:45: Polycom Austin:
192.168.1.101:connecting:384:0:videocall
notification:callstatus:outgoing:45: Polycom Austin:
192.168.1.101:connected:384:0:videocall
```

Note :The call ID number (45) is an example of the response. The Call ID number depends upon the call type.

Limitations

None

Comments

None

See also

You can use `callstate register` or `notify callstatus` to obtain updated information on the status of a call. For example, when using `dial manual` to place a call, both registration commands will tell you when the call is connected. Refer to the [callstate](#) command and the [notify](#) command.

gendial

Generates DTMF dialing tones.

Syntax

```
gendial <{0..9} | # | * >
```

Table 1.

Parameter	Description
{0..9}	Generates the DTMF tone corresponding to telephone buttons 0-9.
#	Generates the DTMF tone corresponding to a telephone # button.
*	Generates the DTMF tone corresponding to a telephone * button.

Feedback Examples

- `gendif 2`
returns
`gendif 2`
and causes the system to produce the DTMF tone corresponding to a telephone's 2 button

Limitations

None

Comments

None

gendifset

Audible dual-tone multi-frequency (DTMF) tones are disabled when making a call on a Poly G7500 system using a connected Poly Group Series device in Poly Video mode.

Syntax

`gendifset <get|inband|outband|both>`

Table 1.

Parameter	Description
<code>get</code>	Returns the current settings.
<code>inband</code>	Sends a DTMF tone to the near end.
<code>outband</code>	Sends a DTMF tone to the far end.
<code>both</code>	Sends a DTMF tone to both the near and far end.

Feedback Examples

- `gendifset get`
returns
`gendifset both`
and causes the system to produce the DTMF tone on both the near and far end.

Limitations

None

Comments

None

generatetone

Turns the test tone on or off. The tone is used to check the monitor audio cable connections or to monitor the volume level.

Syntax

```
generatetone <on|off>
```

Table 1.

Parameter	Description
on	Turns on the test tone.
off	Turns off the test tone.

Feedback Examples

- `generatetone on`
returns
`generatetone on`
and the system produces a test tone
- `generatetone off`
returns
`generatetone off`
and the system stops producing a test tone

Limitations

None

Comments

None

getcallstate

Gets the state of the calls in the current conference.

Syntax

```
getcallstate
```

Feedback Examples

- `getcallstate`
returns

returns

```
cs: call[34] speed[384] dialstr[192.168.1.101] state[connected]  
cs: call[1] inactive  
cs: call[2] inactive
```

Limitations

None

Comments

None

See Also

To register the shell session to receive notifications about call state activities, see the [callstate](#) command.

hangup

Hangs up the video call.

Syntax

```
hangup video ["callid"]  
hangup all
```

Table 1.

Parameter	Description
video	Disconnects the current video call. If the "callid" parameter is omitted, the system disconnects all video far sites in the call.
all	Disconnects all video and audio sites in the call.

Feedback Examples

- `hangup video`
returns
`hanging up video`
- `hangup video 42`
returns
`hanging up video`
and disconnects the specified site, leaving other sites connected
- If callstate register is used for notifications,
`hangup video 42`
returns
`hanging up video`
`cleared: call[42]`
`dialstring[IP:192.168.1.101 NAME:Demo]`
`ended: call[42]`
and disconnects the specified site, leaving other sites connected

Limitations

None

Comments

After sending the hangup command, if registered for notification, the feedback response will notify that the call has ended. The feedback response can take up to 15 seconds.

maxtimeincall

Gets or sets the maximum number of minutes allowed for call length.

Syntax

```
maxtimeincall get
maxtimeincall set [{0..2880}]
```

Table 1.

Parameter	Description
get	Returns the current setting.
set	Sets the maximum timefor calls when followed by a parameter from {0..2880}.To erase the current setting, omit the time parameter or set it to 0.The call will then stay up indefinitely.
{0..2880}	Maximum call time in minutes. Must be an integer in the range {0..2880}.The value in minutes will be rounded up to hours in the system, the valid hour values are 1_hour, 2_hours to 12_hours, 24_hours and 48_hours.

Feedback Examples

- maxtimeincall set
returns
maxtimeincall <empty>
- maxtimeincall set 180
returns
maxtimeincall 180
- maxtimeincall get
returns
maxtimeincall 180

Limitations

None

Comments

When the time has expired in a call, a message asks you if you want to hang up or stay in the call. If you do not answer within one minute, the call automatically disconnects.

mute

Gets or sets near- or far-site mute settings.

Syntax

```
mute <register|unregister>
mute near <get|on|off|toggle>
mute far get
```

Table 1.

Parameter	Description
register	Registers to receive notification when the mute mode changes.
unregister	Disables register mode.
near	Sets the command for the near site. Requires on,off,toggle,or get.
get	Returns the current setting for the near or far site.
on	Mutes the near site (mutenear on).
off	Unmutes the near site (mutenear off).
toggle	If mute near mode is mutenear on,this switches to mutenear off,and vice versa.
far	Returns the mute state of the far site system. Requires the parameter get.

Feedback Examples

- mute register
returns

mute registered

- mute near on
returns
mute near on
- mute far get
returns
mute far off

Limitations

None

Comments

In register mode, the system sends notification to the API session when the far or near site is muted or unmuted.

muteautoanswer

Gets or sets if the audio is muted for auto-answered calls. When this is on, your microphone is muted to prevent the far site from immediately hearing the near site.

Syntax

muteautoanswer <get|yes|no>

Table 1.

Parameter	Description
get	Returns the current setting.
yes	Enables Mute Auto Answer Calls mode. The microphone will be muted when the system receives a call while in Auto Answer mode.
no	Disables Mute Auto Answer Calls mode. The microphone is not muted when the system automatically answers calls.

Feedback Examples

- muteautoanswer yes

```
returns
muteautoanswer yes
```

- muteautoanswer no
returns
muteautoanswer no
- muteautoanswer get
returns
muteautoanswer no

Limitations

None

Comments

None

volume

Gets or sets the call audio volume (not sound effects) on the system or registration for volume changes. Changes the call audio volume (not sound effects) on the system.

Syntax

```
volume <register|unregister>
volume <get|up|down|set {0..50}>
volume range
```

Table 1.

Parameter	Description
register	Registers to receive notification when the volume changes.
unregister	Disables register mode.
get	Returns the current volume level.
up	Increases the audio volume by 1.

Parameter	Description
down	Decreases the audio volume by 1.
set	Sets the volume to a specified level. Requires a volume setting from {0..50}.
range	Returns the valid volume range available to the user.

Feedback Examples

- volume register
returns
volume registered
- If entered again, volume register
returns
info: event/notification already active:volume
- volume set 23
returns
volume 23
- volume up
returns
volume 24
- volume get
returns
volume 24

Limitations

None

Comments

Changes the call audio volume (not sound effects) on the system.

recentcalls

Returns a list of recent calls.

Syntax

```
recentcalls
```

Additional Restrictions

None

Feedback Examples

- recentcalls
returns
"Polycom Demo" 30/Sep/2015 14:39:56 Out
192.168.1.101 30/Sep/2015 14:39:56 Out
192.168.1.102 30/Sep/2015 14:40:35 Out
192.168.1.103 30/Sep/2015 20:27:33 Out
"John Polycom" 30/Sep/2015 02:13:23 In
192.168.1.104 30/Sep/2015 02:20:08 In
192.168.1.105 30/Sep/2015 02:21:40 In
192.168.1.106 30/Sep/2015 05:53:04 In
"Mary Polycom" 30/Sep/2015 07:00:19 In

Limitations

None

Comments

The number of items returned depends on the value entered for the **Maximum Number to Display** option in the web interface.

videomute

Gets or sets the transmission of local video to the far site.

Syntax

```
videomute near <get|on|off>
```

Table 1.

Parameter	Description
get	Returns the current setting.
near	Specifies local video.

Parameter	Description
on	Turns on video mute, so no video is transmitted.
off	Turns off video mute, so video is transmitted normally.

Feedback Examples

- videomute near get
returns
viedoemute near off
- videomute near on
returns
videomute near on
- videomute near off
returns
videomute near off

Limitations

None

Comments

None

videocallorder

Gets or sets the video call order of the specified protocol to the specified slot.

Syntax

```
videocallorder <h323|sip> <1|2|3|4>
```

Table 1.

Parameter	Description
h323	Specifies IP protocol.
sip	Specifies SIP protocol.
1 2 3 4	Sets the order in which the specified protocol is attempted when a video call is placed.

Feedback Examples

- `videocallorder h323 1`
returns
`videocallorder h323 1`
- `videocallorder sip 2`
returns
`videocallorder sip 2`

Limitations

None

Comments

None

Camera APIs

- [camera](#)
Sets or gets the near- or far-site camera settings.
- [configparam](#)
Gets or sets the video quality setting for the specified video input for motion or sharpness.
- [farcontrolnearcamera](#)
Gets or sets far control of the near camera, which allows far sites to control the camera on your system.
- [preset](#)

Sets the presets or goes (moves) to the presets for the near or far camera. Also registers or unregisters the API session to notify when the user sets or goes to presets.

camera

Sets or gets the near- or far-site camera settings.

Syntax

```
camera near {1..4}
camera far {1..4}
camera <near|far> move <left|right|up|down|zoom+|zoom-|stop>
camera <near|far> source
camera <near|far> stop
camera near <getposition|setposition "x" "y" "z">
camera near tracking statistics
camera near tracking <get|on|off>
camerainvert near <get|on|off>
```

Table 1.

Parameter	Description
get	Returns the current setting.
on	Sets the camera to present an inverted (upside down) video image.
off	Sets the camera to present a normal (right-side up) video image.
near	Specifies that the command selects or controls the near camera.
far	Specifies that the command selects or controls the far camera.
{1..4}	Specifies a near or far camera as the main video source.

Parameter	Description
move	Changes the near or far camera's direction or zoom. Valid directions are: left, right, up, down, zoom+, zoom-, and stop.
left	Starts moving the camera left.
right	Starts moving the camera right.
up	Starts moving the camera up.
down	Starts moving the camera down.
zoom+	Starts zooming in.
zoom-	Starts zooming out.
stop	Stops the movement of the near or far camera. Returns no feedback.
source	Returns the number of the near or far camera source currently selected.
getposition	Gets the pan, tilt, and zoom coordinates of the currently selected PTZ camera in the format of pan tilt zoom.

Parameter	Description
<pre>setposition "x" "y" "z"</pre>	<p>Sets the pan (x),tilt (y),and zoom (z)coordinates of the selected PTZ camera.</p> <hr/> <p>Note Different cameras might have different PTZ values. Some D30 cameras might not be able to reach the full range limit. For example,although the pan limit is 5000, the camera might only be able to reach a nearby value.</p> <hr/>
<pre>tracking statistics</pre>	<p>Gets tracking statistics. Tracking statistics measure:</p> <ul style="list-style-type: none"> • The amount of time tracking is turned off divided by the total call time in the most recent 100 calls lasting more than five minutes. • The amount of room and close-up view switches divided by the total call time in the most recent 100 calls lasting more than five minutes.
<pre>tracking <get on off></pre>	<p>Enables or disables the Poly EagleEye Director II or EagleEye Producer camera tracking feature. on turns the tracking feature on, off turns the tracking feature off, and get returns the current tracking feature setting.</p>
<pre>camerainvert near</pre>	<p>Sets the video image of the EagleEye IV camera to upside down (on) or normal (off).</p>

Feedback Examples

- camera far 2 specifies camera 2 at the far-site and returns camera far 2
- camera far move left causes the far-site camera to start panning to the left and returns event: camera far move left
- camera near move zoom+causes the near-site camera to zoom in and returns event : camera near move zoom+

- camera near tracking off
returns
camera near tracking off
- camera near tracking on
returns
camera near tracking on
- camera near setposition 100 100 219
returns
camera near setposition 100 100 219
- camera near getposition
returns
camera near getposition 100 99 218
- camerainvert near get
returns
camerainvert near off
- camerainvert near on
returns
camerainvert near on
- camerainvert near off
returns
camerainvert near off

Limitations

None

Comments

The camera commands function only when the system is in a wake state. If necessary, use the wake command prior to using the camera commands.

If the camera near {1..4} API command is used for an input configured as content, the command becomes a toggle. You must send the command once to send the content source and a second time to stop the content source.

After using a camera command to move a Polycom EagleEye Producer or Polycom EagleEye Director II camera, you must use the camera <near|far> stop command to update the camera position.

configparam

Gets or sets the video quality setting for the specified video input for motion or sharpness.

Syntax

```
configparam <"parameter"> get  
configparam <"parameter"> set <"value">
```

Table 1.

Parameter	Description
get	Gets the video quality setting for the specified video input.
set	Sets the video quality setting for the specified video input.
camera_video_quality <motion sharpness>	Sets the video quality setting for the specified video input for motion or for sharpness (for images without motion).

Feedback Examples

- ```
configparam camera_video_quality 1 set motion
returns
camera1_video_quality motion
```
- ```
configparam camera_video_quality 1 get  
returns  
camera1_video_quality sharpness
```

Limitations

None

Comments

None

farcontrolnearcamera

Gets or sets far control of the near camera, which allows far sites to control the camera on your system.

Syntax

```
farcontrolnearcamera <get|yes|no>
```

Table 1.

Parameter	Description
get	Returns the current setting.
yes	Allows the far site to control the near camera if the far site has this capability.
no	Disables far-site control of the near camera.

Feedback Examples

- `farcontrolnearcamera yes`
returns
`farcontrolnearcamera yes`
- `farcontrolnearcamera no`
returns
`farcontrolnearcamera no`
- `farcontrolnearcamera get`
returns
`farcontrolnearcamera no`

Limitations

None

Comments

None

preset

Sets the presets or goes (moves) to the presets for the near or far camera. Also registers or unregisters the API session to notify when the user sets or goes to presets.

Syntax

```

preset <register|unregister>
preset register get
preset far <go|set> <{0..15}>
preset near <go|set> <{0..99}>

```

Table 1.

Parameter	Description
register	Registers the system to give notification when the user or far site sets or goes to a preset. Returns the current preset registration state when followed by the getparameter.
unregister	Disables register mode.
far	Specifies the far camera. Requires a setorgoparameterand a preset identifier.
go	Moves the camera to a camera preset. Requires a "preset" parameter.
set	Sets a camera preset. Requires a "preset" parameter.
{0..15}, {0..99}	Camera preset identifier. Must be an integer in the range {0..15}fora far-site camera or {0..99}for a near-site camera.
near	Specifies the near camera. Requires a setorgoparameterand a preset identifier.

Feedback Examples

- preset register
returns
preset registered
- preset near go 1
returns
preset near go 1
and moves the near-site camera to the preset 1 position
- preset near set 2

returns

```
preset near set 2
```

and saves the current location/position of the near-site camera as preset 2

Limitations

None

Comments

Up to 100 preset camera positions can be set.

Directory and contacts APIs

- [addrbook](#)
Returns local directory (address book) entries.
- [dial addressbook_entry](#)
Dials a system using a unique identifier retrieved by the globaldir command.
- [exportdirectory](#)
Exports a directory in XML format.
- [favorites](#)
Returns entries in the Favorites list. Favorites can link to local or global directory entries.
- [gdirectory](#)
Gets or sets options for the Poly Global Directory Service (GDS).
- [gdpassword](#)
Sets the password for Poly GDS registration.
- [gdserverip](#)
Gets or sets the GDS server IP address.
- [globaldir](#)
Retrieves global directory entries. Poly recommends that you use this command for the Global Directory. This command supports all global directory types, including Poly GDS and LDAP.
- [importdirectory](#)
Imports local directory information in XML format.
- [localdir](#)
Retrieves local directory entries (Favorites).
- [importprofile](#)
Imports system and user profile information in a CSV format.

addrbook

Returns local directory (address book) entries.

Syntax

Commands for local directory

```
addrbook all
addrbook batch {0..59}
addrbook batch search "pattern" "count" addrbook batch define "start_no" "stop_no"
addrbook letter {a..z}
addrbook range "start_no" "stop_no"
```

Commands for groups

```
addrbook names <all|video> [<range_start>] [<range_end>]
addrbook names <all|video> size
addrbook names search "search_pattern" <all|video>
[<range_start>] [<range_end>]
addrbook names search "search_pattern" <all|video> size
addrbook group "group_name" [<range_start>] [<range_end>]
addrbook group "group_name" size
addrbook address "sys_name" ["sys_label"]
```

Table 1.

Parameter	Description
all	Returns all the entries in the local directory.
batch	Returns a batch of 10 local directory entries. Requires a batch number, which must be an integer in the range {0..59}.
search	Specifies a batch search.
"pattern"	Specifies a pattern to match for the batch search.
"count"	Specifies the number of entries to list that match the pattern.
define	Returns a batch of entries in the range defined by "start_no" to "stop_no."

Parameter	Description
letter	<p>Returns entries beginning with the letter specified from the range {a..z}. Requires one or two alphanumeric characters. Valid characters are:</p> <p>-_ / ; @ , . \</p> <p>0through 9 athroughz</p>
range	<p>Returns local directory entries numbered "start_no" through "stop_no". Requires two integers.</p>
"start_no"	<p>Specifies the beginning of the range of entries to return.</p>
"stop_no"	<p>Specifies the end of the range of entries to return.</p>
names	<p>Returns a list of system names in the local address book. Also returns the system type: video, multicodec, phone, or multisite. A multicodec system will appear as a single row. The response is in the following format:</p> <pre> addrbooknames {0..n}. name:"sys_name" sys_label:"sys_label" type:<video multicodec phone group> ... addrbooknames <all video phone> done </pre>

Parameter	Description
<all video>	<p>Specifies the type of entries to return. video returns</p> <p>returns</p> <p>entries that have video addresses. all returns</p> <p>returns</p> <p>entries with video numbers or phone numbers or both.</p>
size	<p>Returns the size of the result set that will be returned by the command. The size parameter can be used with the names and the names search commands.</p> <p>The response is in the following format:</p> <pre>addrbooknames <all video phone> size {0..n} addrbook names search "search" <all video phone>size {0..n}</pre>
range_start	<p>For the names, names search, and group commands, specifies the beginning of the range of entries to return.</p>
range_end	<p>For the names, names search, and group commands, specifies the end of the range of entries to return. If a range_start is specified without a range_end, then the single range_start entry will be returned. If range_end is -1, all entries starting with range_start will be returned.</p>

Parameter	Description
search	<p>Returns a list local directory names that match the search criteria. The response is similar to the names command described above:</p> <pre>addrbook search {0..n}. name: "sys_name" sys_label: "sys_label" type: <video multicodec phone group> ... addrbooknames search "search_pattern" <all video phone> done</pre>
search_pattern	<p>Specifies the string pattern for which to search. Wildcard characters are not supported. The search string is used to match the beginning of any of the attributes listed using descriptions for the names and search parameters. For example, the search string "Jo" would match any name that begins with Jo, such as John or Jones. The search is not case sensitive.</p>
group	<p>Returns a list of the names of all the sites included in a local directory group in this format:</p> <pre>addrbookgroup {0..n}. name: "site_sys_name" sys_label: "site_sys_label" ... addrbookgroup "group_name" [range] done addrbook group size <num_e</pre>
group_name	<p>A local address book group name.</p>

Parameter	Description
address	Obtains the address information for a specified entry. If the entry is an ITP system, the results will include the addresses for all codecs. If codecs support multiple protocols, the different addresses will be returned on separate lines. This command is not supported for multisite entries.
sys_name	The friendly name for an address book entry. It is the name of the person or the room. It is surrounded by quotes if it contains spaces.
sys_label	If a person/room has more than one system, the result set will include a row for each system. If those systems are of the same type the client will consider that entry to be a telepresence system with multiple codecs rather than separate systems. If the systems are of different types, then this <code>sys_label</code> attribute will be included to differentiate the systems.
type	The type of local address book entry. Possible values are: <code>video,multicodec, phone, group</code>
site_sys_name	The name of a site in a group. It is surrounded by quotes if it contains spaces
site_sys_label	The label associated with a site name in a local group. It is surrounded by quotes if it contains spaces.
codec:<1..4>	If the entry is a telepresence system, each codec will include a codec number attribute.

Parameter	Description
h323_spd	The preferred speed for an H.323 call to this entry. If no speed is associated with the entry, then the value of the configuration variable globaladdrmaxh323 is returned. The default is 384.
h323_num	H.323 address or alias.
h323_ext	H.323 extension or E.164 number.
sip_spd	The preferred speed for a SIP call to this entry. If no speed is associated with the entry, then this is the same as the h323_spd.
sip_num	IP address.

Feedback examples

- `addrbook all`

returns

```
addrbook 0. "Polycom Demo 1" h323_spd:384 h323_num:192.168.1.101
h323_ext:7878
addrbook 1. "Polycom Demo 2" sip_spd:384 sip_num:polycomg7500@polycom.com
addrbook 2. "Polycom Demo 3" phone_num:1.512.5121212
(and so on, until all entries in the local directory are listed, then:)
addrbook all done
```

- `addrbook batch 0`

returns

```
addrbook 0. "Polycom Demo 1" h323_spd:384 h323_num:192.168.1.101
h323_ext:7878
addrbook 1. "Polycom Demo 2" sip_spd:384 sip_num:polycomg7500@polycom.com
addrbook 2. "Polycom Demo 3" phone_num:1.512.5121212
(and so on, through the last entry in the batch of 10 directory entries, such as:
addrbook 9. "Polycom Demo 20" h323_spd:384 h323_num:192.168.1.120 h323_ext:
addrbook batch 0 done
```

- `addrbook batch define 0 2`

returns

```
addrbook 0. "Polycom Demo 1"
h323_spd:384 h323_num:192.168.1.101 h323_ext:7878
```

```
addrbook 1. "Polycom Demo 2" sip_spd:384 sip_num:polycom@polycom.com
addrbook batch define 0 2 done
```

- addrbook names all size

returns

```
addrbook names all size 21
```

- addrbook names all size 21

returns

```
addrbook names all size 21
```

```
addrbook names 0. name:"Eng RPX" sys_label:"" type:multicodec
addrbook names 1. name:"Doe" sys_label:"" type:video
addrbook names 2. name:"Gen Group" sys_label:"" type:group
addrbook names 3. name:"John Doe" sys_label:"" type:video
addrbook names 4. name:"John Doe" sys_label:"" type:video
addrbook names 5. name:"Lab TPX" sys_label:"" type:video
addrbook names 6. name:"Minuteman RPX" sys_label:"" type:multicodec
addrbook names 7. name:"Monday Staff Mtg" sys_label:"" type:group
addrbook names 8. name:"Polycom Austin Stereo" sys_label:"" type:video
addrbook names 9. name:"Polycom Austin HD" sys_label:"" type:video
addrbook names all 0 9 done
```

- addrbook names all

returns

```
addrbook names 0. name:"Eng RPX" sys_label:"HDX" type:multicodec
addrbook names 1. name:"Doe" sys_label:"" type:video
addrbook names 2. name:"Gen Group" sys_label:"" type:group
addrbook names 3. name:"John Doe" sys_label:"" type:video
addrbook names 4. name:"John Doe" sys_label:"" type:video
addrbook names 5. name:"Lab TPX" sys_label:"" type:video
addrbook names 6. name:"Minuteman RPX" sys_label:"" type:multicodec
addrbook names 7. name:"Monday Staff Mtg" sys_label:"" type:group
addrbook names 8. name:"Polycom Austin Stereo" sys_label:"" type:video
addrbook names 9. name:"Polycom Austin HD" sys_label:"" type:video
addrbook names 10. name:"Polycom Austin USA IP" sys_label:"" type:video
addrbook names 11. name:"Polycom Japan" sys_label:"" type:video
addrbook names 12. name:"Scott CMAD IP" sys_label:"" type:video
addrbook names 13. name:"Scott Phone" sys_label:"" type:phone
addrbook names 14. name:"Scott PVX" sys_label:"" type:video
addrbook names 15. name:"Scott Quasar 19" sys_label:"" type:video
addrbook names 16. name:"SQA " sys_label:"" type:video
addrbook names 17. name:"John Doe" sys_label:"" type:video
addrbook names 18. name:"Test System 1" sys_label:"" type:video
addrbook names 19. name:"Test System 2A" sys_label:"" type:video
addrbook names 20. name:"Test System 2B" sys_label:"" type:video
addrbook names all done
```

- addrbook names search "p" all

returns

```
addrbook search 0. name:"Polycom Austin HD" sys_label:"" type:video
addrbook search 1. name:"Polycom Austin Stereo" sys_label:"" type:video
addrbook search 2. name:"Polycom Austin USA IP" sys_label:"" type:video
addrbook search 3. name:"Polycom Japan" sys_label:"" type:video
addrbook search 4. name:"Scott Phone" sys_label:"" type:phone
```

- ```
addrbook search 5. name:"Scott Group Series" sys_label:"" type:video
addrbook search search p all done
```
- `addrbook names search "p" all 0 2`

```
returns
addrbook search 0. name:"Polycom Austin HD" sys_label:"" type:video
addrbook search 1. name:"Polycom Austin Stereo" sys_label:"" type:video
addrbook search 2. name:"Polycom Austin USA IP" sys_label:"" type:video
addrbook search search p all 0 2 done
```
  - `addrbook group "Monday Staff Mtg"`

```
returns
addrbook group 0. name:"Eng RPX" sys_label:"HDX"
addrbook group 1. name:"John Doe" sys_label:""
addrbook group 2. name:"John Doe" sys_label:""
addrbook group 3. name:"TPW" sys_label:"HDX"
addrbook group "Monday Staff Mtg" done
```
  - `addrbook address "John Doe"`

```
returns
addrbook address 0. name:"John Doe" sys_label:"" codec:1
 h323_spd:384 h323_num:172.25.137.101 h323_ext:
addrbook address name:"John Doe" sys_label:"" done
```

#### Limitations

None

#### Comments

This command is deprecated. Poly recommends using `localdir` instead.

## ***dial addressbook\_entry***

Dials a system using a unique identifier retrieved by the `globaldir` command.

#### Syntax

```
dial addressbook_entry "UID"
```

Table 1.

| Parameter | Description                                                                                                                                                                |
|-----------|----------------------------------------------------------------------------------------------------------------------------------------------------------------------------|
| "UID"     | <p>Unique identifier associated with a site or group, for example:<br/> <code>ldap#g#f82be96eea3bd644a1963dc7fdf45011</code></p> <p>The complete UID must be specified</p> |

#### Feedback Examples



- dial addressbook\_entry ldap#g#35086aa0ecc9014facdcaa89bd34ccf6  
returns  
dialing addressbook\_entry  
ldap#g#35086aa0ecc9014facdcaa89bd34ccf6Comments

#### Limitations

None

#### Comments

The "UID" value must be retrieved by the globaldir command.

## **exportdirectory**

Exports a directory in XML format.

#### Syntax

exportdirectory

#### Additional Restrictions

None

#### Feedback Examples

- exportdirectory  
returns  
exportdirectory started  
<?xml version="1.0" encoding="UTF-8" ?>  
<addresses>  
<entrytype type="entry" name="dawn" filename="dawn" uniqueid="local:26">  
<address filename="dawn " langid=" "  
" displayname="dawn " name="dawn">  
<h323 address="192.168.1.120"  
speed="0" ^  
<sip address="192.168.1.120" speed="0" ^  
<category category="CONTACTS" ^  
</address>  
</entrytype>  
<entrytype type="entry" name="dawn " filename="dawn " uniqueid="local:28">  
<address filename="dawn " langid=" "  
" displayname="dawn " name="dawn ">  
<h323 address="192.168.1.120"  
speed="0" ^  
<sip address="192.168.1.120" speed="0" ^  
<category category="CONTACTS" ^  
</address>  
</entrytype>  
<address filename="testGroup " langid=" "

```

" displayname="testGroup " name="testGroup ">
<multisitename meeting_name="testGroup " ^
<multisitespeed meeting_speed="auto" ^
<multisitename0 site_name_0="dawn " ^
<multisitetype0 site_type_0="2" type_0="1000" ^
<multisiteprefcalltype0 pref_call_type_0="H323" ^
<multisiteuniqueid0 unique_id_0="local:28" ^
<multisitename1 site_name_1="dawn2 " ^
<multisitetype1 site_type_1="2" type_1="1000" ^
<multisiteprefcalltype1 pref_call_type_1="H323" ^
<multisiteuniqueid1 unique_id_1="local:30" ^
<multisitename2 site_name_2="dawn3 " ^
<multisitetype2 site_type_2="2" type_2="1000" ^
<multisiteprefcalltype2 pref_call_type_2="H323" ^
<multisiteuniqueid2 unique_id_2="local:29" ^
<address>
<entrytype>
<entrytype type="group" name="testGroup1" filename="testGroup1" uniqueid="local:38" ^
<address filename="testGroup1 " langid="
" displayname="testGroup1 " name="testGroup1">
<multisitename meeting_name="testGroup1" ^
<multisitespeed meeting_speed="auto" ^
<address>
<entrytype>
<addresses>
<xml> exportdirectory done

```

## Limitations

None

## Comments

`exportdirectory done` indicates that all directory data has been exported.

Do not use the `exportdirectory` command to interpret the data that is returned. Simply store and use the data as input to the `importdirectory` command or import directory utility in the web interface. The format of the exported directory data might change in future software releases and any application attempting to interpret the data could find its ability to do so compromised in later software releases.

Exporting a directory on one system model and importing the directory on another model is not supported. Attempts to export and import directory information between different systems might also fail. The message `importdirectory failed` indicates that the system was not able to import the information.

When importing directory data back into the system, use the data in its entirety (not edited in any form). There is information that is used by the system to determine what type (XML or CSV) of data is being imported.

## See also

See the [importdirectory](#) command.

## favorites

Returns entries in the Favorites list. Favorites can link to local or global directory entries.

### Syntax

```
favorites names <all|video|phone> [range_start] [range_end]
favorites names <all|video|phone> size
favorites address "sys_name" ["sys_label"]
```

Table 1.

| Parameter         | Description                                                                                                                                                                                                                                                                                                                                    |
|-------------------|------------------------------------------------------------------------------------------------------------------------------------------------------------------------------------------------------------------------------------------------------------------------------------------------------------------------------------------------|
| names             | <p>Returns names in the Favorites list and the associated system type: video, multicodec, phone, or multisite (a multicodec system displays as a single row). The response is in the following format:</p> <pre>favoritesnames name:"sys_name"sys_label:"sys_label" " type: &lt;video multicodec phone multisite&gt; favoritesnames done</pre> |
| <all video phone> | <p>video</p> <p>returns</p> <p>returns</p> <p>entries with video systems, phone</p> <p>returns</p> <p>entries with phone systems, and all</p> <p>returns</p> <p>returns</p> <p>entries with both types.</p>                                                                                                                                    |

| Parameter   | Description                                                                                                                                                                                                                                                                                                                                           |
|-------------|-------------------------------------------------------------------------------------------------------------------------------------------------------------------------------------------------------------------------------------------------------------------------------------------------------------------------------------------------------|
| size        | <p>Specifies the size of the returned set based on the parameters you are including. For example, a response could look like this:</p> <pre>favoritesnames video size 9</pre>                                                                                                                                                                         |
| range_start | <p>For the names parameter, it specifies the beginning of the range of entries to return.</p>                                                                                                                                                                                                                                                         |
| range_end   | <p>For the names parameter, it specifies the end of the range of entries to return.</p> <p>If range_start is specified without a range_end, the single range_start entry is returned. If range_end is -1, all entries starting with range_start are returned.</p>                                                                                     |
| address     | <p>Obtains the address information for a specified entry. If the entry is an ITP system, the results include the addresses for all its codecs. If the codecs support multiple protocols, the different addresses are returned on separate lines. This parameter is not supported for multisite entries.</p>                                           |
| sys_name    | <p>The user-friendly name for a Favorites entry (for example, the name of a person or room). It is surrounded by quotes if it contains spaces.</p>                                                                                                                                                                                                    |
| sys_label   | <p>If a person or room has more than one system, the returned set includes a row for each system. If those systems are of the same type, it is considered to be a single ITP system with multiple codecs rather than separate systems. If there are different types of systems, the sys_label parameter is included to differentiate the systems.</p> |
| type        | <p>The type of Favorites entry (possible values are video, multicodec, phone, and multisite).</p>                                                                                                                                                                                                                                                     |

| Parameter    | Description                                                                                                             |
|--------------|-------------------------------------------------------------------------------------------------------------------------|
| codec:<1..4> | If the entry is an ITP system, each codec has a unique value.                                                           |
| h323_spd     | The preferred speed for an H.323 call to this entry.                                                                    |
| h323_num     | H.323 address or alias.                                                                                                 |
| h323_ext     | H.323 extension or E.164 number.                                                                                        |
| sip_spd      | The preferred speed for a SIP call to this entry. If no speed is associated with the entry, it is the same as h323_spd. |
| sip_num      | SIP address.                                                                                                            |
| xmpp_addr    | XMPP address, also known as the Jabber ID (JID).                                                                        |

#### Feedback Examples

- favorites names all  
 returns  
 favorites names 0. name:"Evergreen" sys\_label:"" type:video  
 favorites names 1. name:"Lab" sys\_label:"groupseries" type:video  
 favorites names 2. name:"Magnolia" sys\_label:"" type:video  
 favorites names 3. name:"Vineyard" sys\_label:"" type:multicodec  
 favorites names all done
- favorites names all 0 1  
 returns  
 favorites names 0. name:"Evergreen" sys\_label:"" type:video  
 favorites names 1. name:"Vineyard" sys\_label:"" type:multicodec  
 favorites names all 0 1 done

If an entry is an ITP system, the address parameter returns information about each of its codecs. A `sys_label` attribute is also returned to identify the endpoint types.

- favorites address "Vineyard" ""

returns

```
favorites address 0. name:"Vineyard" sys_label:"" codec:1 h323_spd:384 h323_num:
favorites address 1. name:"Vineyard" sys_label:"" codec:2 h323_spd:384 h323_num:
favorites address 2. name:"Vineyard" sys_label:"" codec:3 h323_spd:384 h323_num:
favorites address name:"Vineyard" sys_label:"" done
```

#### Limitations

None

#### Comments

You do not need to enclose a value in quotes unless it contains a space.

## ***gdsdirectory***

Gets or sets options for the Poly Global Directory Service (GDS).

#### Syntax

```
gdsdirectory <get|on|off|status>
```

Table 1.

| Parameter | Description                                  |
|-----------|----------------------------------------------|
| get       | Returns the current setting.                 |
| On        | Enables GDS registration.                    |
| Off       | Disables GDS registration.                   |
| status    | Returns the current GDS registration status. |

#### Feedback Examples

- gdsdirectory get  
returns  
gdsdirectory off
- gdsdirectory on  
returns

gdsdirectory on

- gdsdirectory status  
returns  
gdsdirectory online

Limitations

None

Comments

The gdsdirectory command is supported only when H.323 is enabled.

## ***gdspassword***

Sets the password for Poly GDS registration.

Syntax

```
gdspassword set <"password">
```

Table 1.

| Parameter  | Description                                  |
|------------|----------------------------------------------|
| set        | Sets the GDS registration password.          |
| "password" | The GDS password when using the set command. |

Feedback Examples

- gdspassowrd set "polycomuser 01"  
returns  
gdspassword failed
- gdspassword set "polycomuser01"  
returns  
gdspassword accepted

Limitations

None

## Comments

The `gdspassword` command is supported only when H.323 is enabled.

## ***gdserverip***

Gets or sets the GDS server IP address.

### Syntax

```
gdserverip <get|set> <"ipaddress">
```

Table 1.

| Parameter   | Description                         |
|-------------|-------------------------------------|
| get         | Returns the current setting.        |
| set         | Specifies the IP address.           |
| "ipaddress" | IP address to use with set command. |

### Feedback Examples

- `gdserverip get`  
returns  
`gdserverip 192.168.1.1`
- `gdserverip set 192.168.1.1`  
returns  
`gdserverip 192.168.1.1`

### Limitations

None

### Comments

The `gdserverip` command is supported only when H.323 is enabled.

## ***globaldir***

Retrieves global directory entries. Poly recommends that you use this command for the Global Directory. This command supports all global directory types, including Poly GDS and LDAP.



## Syntax

```
globaldir "search_string"
globaldir "search_string" "size"
globaldir entry "UID"
globaldir range "start_no" "end_no"
globaldir "search_string" range "start_no" "end_no"
```

### **Multi-Tiered Directory Commands**

```
globaldir grouplist
globaldir grouplist "UID"
globaldir grouplist "UID" "search_string"
globaldir grouplist "UID" range "start_no" "end_no"
globaldir grouplist "UID" "search_string" range "start_no" "end_no"
```

Table 1.

| Parameter      | Description                                                                                                                                              |
|----------------|----------------------------------------------------------------------------------------------------------------------------------------------------------|
| "searchstring" | The name or string to use for the search. If the string has a space, you must enclose it in quotations.                                                  |
| "size"         | Specifies the maximum number of entries to return in the search.                                                                                         |
| entry          | Retrieves information about a specific site.                                                                                                             |
| grouplist      | Retrieves the top tier of the group list when using a multitiered directory on Poly RealPresence Resource Manager.                                       |
| "UID"          | Unique identifier associated with a site or group.<br>For example:<br>ldap#g#f82be96eea3bd644a1963dc7fdf45011<br><br>The complete UID must be specified. |
| range          | Returns local directory entries numbered "start_no" through "stop_no". Requires two integers.                                                            |

| Parameter  | Description                                                |
|------------|------------------------------------------------------------|
| "start_no" | Specifies the beginning of the range of entries to return. |
| "stop_no"  | Specifies the end of the range of entries to return.       |

### Feedback Examples

#### LDAP

- `globaldir sd 5`  
returns  

```
globaldir 0. SD-Austin-01a@polycom.com:
ldap#g#840780b28ef4234f84f64298909aca07:site
globaldir 1. SD-Austin-02a@polycom.com:
ldap#g#8852f4c7cb6d9b4fab7e53e2730a5219:site
globaldir 2. SD-Dallas-01a@polycom.com:
ldap#g#83840767145bf04a9ce2b307af6d5688:site
globaldir 3. SD-Dallas-02a@polycom.com:
ldap#g#158aa86dd780ca4f8731fcfd627e05ad:site
globaldir 4. SD-Houston-01a@polycom.com:
ldap#g#e2859e0318bca145ba9b6f641e7f39d2:site
globaldir 5. SD-Houston-02a@polycom.com:
ldap#g#f82be96eea3bd644a1963dc7fdf45011:site
globaldir sd 5 done
```
- `globaldir sd`  
returns  

```
globaldir 0. SD-Austin-01a@polycom.com:
ldap#g#840780b28ef4234f84f64298909aca07:site
globaldir 1. SD-Austin-02a@polycom.com :
ldap#g#8852f4c7cb6d9b4fab7e53e2730a5219:site
through
globaldir 401. SD-Wyoming-01a@polycom.com:
ldap#g#3e98beb689622445af6f35bb0634ea02:site
globaldir 402. SD-Wyoming-02a@polycom.com:
ldap#g#81b735ce3111c445b85c0d0ddf3fd7a4:site
globaldir sd done
```

#### GDS

- `globaldir gro 5`  
returns  

```
globaldir 0. Group Conf Room : gds#485:site
globaldir 1. 1: gds#484:site
```

```
globaldir 2. 2 : gds#466:site
globaldir 3. 3 : gds#512:site
globaldir 4. Austin : gds#474:site
globaldir 5. Boston : gds#394:site
```

- globaldir entry gds#485

returns

```
globaldir 0. " Group Conf Room " h323_spd:1024 h323_num:10.223.17.147 h323_ext: :
globaldir entry gds#485 done
```

## RANGE

- globaldir range 0 9

returns

```
globaldir 0. AUSTIN LAB : ldap#g#2f83d8e0542dc74fac5c2f6e55035cff:group
globaldir 1. Admin Admin : ldap#g#589feda2e097073b52134c7984ca6b44:site
globaldir 2. Admin2 Admin2 : ldap#g#e6b660a112b25d4cb2067243e73da458:site
globaldir 3. G7500 : ldap#g#0410894cfa213c418df5bd1226d46491:group
globaldir 4. Group Series : ldap#g#d62644529aae1643ac7b418b1e404fe4:site
globaldir 5. HDX : ldap#g#011d8db58de14d48838549c5e0ec7465:group
globaldir 6. HDX8000 : ldap#g#38317b15022dc94f83650937c8aa0a48:group
globaldir 7. HDX9000 : ldap#g#5b97459113158744a3989d0bb40ce89e:group
globaldir 8. HDX_MISC : ldap#g#2331576d60cf9948a09860946f38a42b:group
globaldir 9. Sams 700 : ldap#g#35086aa0ecc9014facdcaa89bd34ccf6:site
globaldir range 0 9 done
```

- globaldir gro range 0 9

returns

```
globaldir 0. Group : ldap#g#35086aa0ecc9014facdcaa89bd34ccf6:site
globaldir 1. Group 9006 : ldap#g#e64ffc28a13917488dec8ac97959c80f:site
globaldir 2. Group GS300 : ldap#g#f7474445f7a8cc4d8221e7f452233446:site
globaldir 3. Group GS700 : ldap#g#7922434fc77b6442bd74643f337f7a8e:site
globaldir 4. Group HDX8006A : ldap#g#578b37ab9167d343853e4200145e119c:site
globaldir 5. Group HDX8006B : ldap#g#2ce9b1cf64090e41a0b3e9b42a11edd5:site
globaldir 6. Group HDX8006C : ldap#g#4275fd987e12e445bde9bcbb551dc7e8:site
globaldir 7. Group HDX9004A : ldap#g#f3030565ec10bf4bbbfd1f77e1bdc483:site
globaldir 8. Group HDX9004B : ldap#g#3e0b4c247225014682dbdebc5d6d935b:site
globaldir 9. Group Saturn : ldap#g#5cb47f04e402d7478631ad45b5e6b493:site
globaldir group range 0 9 done
```

## MULTI-TIERED DIRECTORY

- globaldir grouplist

returns

```
globaldir 0. Admin Admin:ldap#g#589feda2e097073b52134c7984ca6b44:site
globaldir 1. Admin2 Admin2:ldap#g#e6b660a112b25d4cb2067243e73da458:site
globaldir 2. G7500:ldap#g#0410894cfa213c418df5bd1226d46491:group
globaldir 3. Group Series:ldap#g#011d8db58de14d48838549c5e0ec7465:group
globaldir 4. HDX_MISC:ldap#g#2331576d60cf9948a09860946f38a42b:group
globaldir 5. Sams 9006:ldap#g#e64ffc28a13917488dec8ac97959c80f:site
```

- ```
globaldir 6. Sams Saturn:ldap#g#5cb47f04e402d7478631ad45b5e6b493:site
globaldir grouplist done
```
- globaldir grouplist ldap#g#011d8db58de14d48838549c5e0ec7465

```
returns
globaldir 0. HDX8000:ldap#g#38317b15022dc94f83650937c8aa0a48:group
globaldir 1. HDX9000:ldap#g#5b97459113158744a3989d0bb40ce89e:group
globaldir grouplist ldap#g#011d8db58de14d48838549c5e0ec7465 done
```
 - globaldir grouplist ldap#g#0410894cfa213c418df5bd1226d46491 boston

```
returns
globaldir 0. Boston GS300:ldap#g#f7474445f7a8cc4d8221e7f452233446
globaldir grouplist ldap#g#0410894cfa213c418df5bd1226d46491 boston done
```
 - globaldir grouplist range 0 6

```
returns
globaldir 0. Admin Admin:ldap#g#589feda2e097073b52134c7984ca6b44:site
globaldir 1. Admin2 Admin2:ldap#g#e6b660a112b25d4cb2067243e73da458:site
globaldir 2. G7500:ldap#g#0410894cfa213c418df5bd1226d46491:group
globaldir 3. Group Series:ldap#g#011d8db58de14d48838549c5e0ec7465:group
globaldir 4. HDX_MISC:ldap#g#2331576d60cf9948a09860946f38a42b:group
globaldir 5. Sams 9006:ldap#g#e64ffc28a13917488dec8ac97959c80f:site
globaldir 6. Sams Saturn:ldap#g#5cb47f04e402d7478631ad45b5e6b493:site
globaldir grouplist range 0 6 done
```
 - globaldir grouplist ldap#g#0410894cfa213c418df5bd1226d46491 range 0 1

```
returns
globaldir 0. GS700:ldap#g#d62644529aae1643ac7b418b1e404fe4:group
globaldir 1. Sams GS300:ldap#g#f7474445f7a8cc4d8221e7f452233446:site
globaldir grouplist ldap#g#0410894cfa213c418df5bd1226d46491 range 0 1 done
```
 - globaldir grouplist ldap#g#e6b660a112b25d4cb2067243e73da458 austin
 range 0 9

```
returns
globaldir 0. Austin 700 : ldap#g#35086aa0ecc9014facdcaa89bd34ccf6:site
globaldir 1. Austin 9006 : ldap#g#e64ffc28a13917488dec8ac97959c80f:site
globaldir 2. Austin GS300 : ldap#g#f7474445f7a8cc4d8221e7f452233446:site
globaldir 3. Austin GS700 : ldap#g#7922434fc77b6442bd74643f337f7a8e:site
globaldir 4. Austin HDX8006A :
ldap#g#578b37ab9167d343853e4200145e119c:site
globaldir 5. Austin HDX8006B :
ldap#g#2ce9b1cf64090e41a0b3e9b42a11edd5:site
globaldir 6. Austin HDX8006C :
ldap#g#4275fd987e12e445bde9bcbb551dc7e8:site
globaldir 7. Austin HDX9004A :
ldap#g#f3030565ec10bf4bbbfd1f77e1bdc483:site
globaldir 8. Austin HDX9004B :
ldap#g#3e0b4c247225014682dbdebc5d6d935b:site
globaldir 9. Austin Saturn : ldap#g#5cb47f04e402d7478631ad45b5e6b493:site
globaldir grouplist ldap#g#e6b660a112b25d4cb2067243e73da458 austin range 0
9 done
```

Limitations

None

Comments

Multitiered directory commands are supported only when using the RealPresence Resource Manager LDAP function.

Using multitiered directory commands on a system that does not support multitiered directory returns the following message: .

```
error: command not supported in current configuration
```

importdirectory

Imports local directory information in XML format.

Syntax

```
importdirectory
<import data line 1>
<import data line 2>
<import data line 3>
.
.
.
importcomplete
```

Additional Restrictions

None

Feedback Examples

- `importdirectory`
returns

```
<?xml version="1.0" encoding="UTF-8" ?>
<addresses>
<entrytype type="entry" name="dawn" filename="dawn" uniqueid="local:26">
<address filename="dawn" langid="" displayname="dawn" name="dawn">
<h323 address="192.168.1.120"
speed="0" ^
<sip address="192.168.1.120" speed="0" ^
<category category="CONTACTS" ^
</address>
</entrytype>
<entrytype type="entry" name="dawn " filename="dawn " uniqueid="local:28">
<address filename="dawn " langid=""
" displayname="dawn " name="dawn ">
<h323 address="192.168.1.120"
speed="0" ^
<sip address="192.168.1.120" speed="0" ^
<category category="CONTACTS" ^
```

```

<address>
<entrytype>
<address filename="test " langid="
" displayname="test " name="test ">
<multisitename meeting_name="test " ^
<multisitespeed meeting_speed="auto" ^
<multisitename0 site_name_0="dawn " ^
<multisitetype0 site_type_0="2" type_0="1000" ^
<multisiteprefcalltype0 pref_call_type_0="H323" ^
<multisiteuniqueid0 unique_id_0="local:28" ^
<multisitename1 site_name_1="dawn2 " ^
<multisitetype1 site_type_1="2" type_1="1000" ^
<multisiteprefcalltype1 pref_call_type_1="H323" ^
<multisiteuniqueid1 unique_id_1="local:30" ^
<multisitename2 site<?xml version="1.0" encoding="UTF-8" ?>
<addresses>
<entrytype type="entry" name="dawn" filename="dawn" uniqueid="local:26">
<address filename="dawn " langid="
" displayname="dawn " name="dawn">
<h323 address="192.168.1.120"
speed="0" ^
<sip address="192.168.1.120" speed="0" ^
<category category="CONTACTS" ^
<address>
<entrytype>
<entrytype type="entry" name="dawn " filename="dawn " uniqueid="local:28">
<address filename="dawn " langid="
" displayname="dawn " name="dawn ">
<h323 address="192.168.1.120"
speed="0" ^
<sip address="192.168.1.120" speed="0" ^
<category category="CONTACTS" ^
<address>
<entrytype>
<address filename="test " langid="
" displayname="test " name="test ">
<multisitename meeting_name="test " ^
<multisitespeed meeting_speed="auto" ^
<multisitename0 site_name_0="dawn " ^
<multisitetype0 site_type_0="2" type_0="1000" ^
<multisiteprefcalltype0 pref_call_type_0="H323" ^
<multisiteuniqueid0 unique_id_0="local:28" ^
<multisitename1 site_name_1="dawn2 " ^
<multisitetype1 site_type_1="2" type_1="1000" ^
<multisiteprefcalltype1 pref_call_type_1="H323" ^
<multisiteuniqueid1 unique_id_1="local:30" ^
<multisitename2 site_name_2="dawn3 " ^
<multisitetype2 site_type_2="2" type_2="1000" ^
<multisiteprefcalltype2 pref_call_type_2="H323" ^
<multisiteuniqueid2 unique_id_2="local:29" ^
<address>
<entrytype>
<entrytype type="group" name="test1" filename="test1" uniqueid="local:38">
<address filename="test1 " langid="
" displayname="test1 " name="test1">

```

```

<multisitename meeting_name="test1" ^
<multisitespeed meeting_speed="auto" ^
<address>
<entrytype>
<addresses>_name_2="dawn3 " ^
<multisitetype2 site_type_2="2" type_2="1000" ^
<multisiteprefcalltype2 pref_call_type_2="H323" ^
<multisiteuniqueid2 unique_id_2="local:29" ^
<address>
<entrytype>
<entrytype type="group" name="test1" filename="test1" uniqueid="local:38">
<address filename="test1 " langid="
" displayname="test1 " name="test1">
<multisitename meeting_name="test1" ^
<multisitespeed meeting_speed="auto" ^
<address>
<entrytype>
<addresses>

```

- `importcomplete`
returns
`import succeeded`

Limitations

None

Comments

A restart of the system is required after successfully importing directory information and occurs automatically after the import is complete.

When importing XML-formatted data, the imported data must be in the same format as was obtained from the system through the `exporthdirectory` command or the export directory utility in the web interface. When importing data back into the system, use the data in its entirety (not edited in any form). The system may use the checksum utility to verify of integrity of the data when it is imported back into the system.

Duplicate entries are overwritten; other entries in the imported directory are added into the system's local directory.

All of the lines entered into the session after `importdirectory` is issued are interpreted as directory data. You must include the `importcomplete` command as the last entry. Issuing the `importcomplete` command on its own line indicates that the directory import is complete.

If no data is received for 60 seconds during import, the import ends, and an `importdirectory timed out` error response is sent to the API session. All previous data entered is ignored.

Attempts to export and import directory information between different systems might fail. The message `import failed` indicates that the system was not able to import the information.

See Also

See the [exporthdirectory](#) command.

localdir

Retrieves local directory entries (Favorites).

Syntax

```
localdir <all>
localdir <search string>
localdir <search string> <size>
localdir entry <UID>
localdir range "start number" "end number"
localdir <search string> range "start number" "end number" localdir grouplist
localdir grouplist <UID>
localdir grouplist <UID> <search string>
localdir grouplist range "start number" "end number"
```

Table 1.

Parameter	Description
*	Returns all site and group entries from the local directory in flat list form.
searchstring	The name or string to use for the search. If the string has a space you must enclose it in quotations.
size	Specifies the maximum number of entries to return in the search.
entry	Retrieves information about a specific site when using a site UID.
UID	Unique identifier associated with a site or group. The UID is the second part of the returned response that follows the colon (":"). You must use the complete UID.
grouplist	Displays entries in the specified group. Using this parameter alone retrieves the top group tier, including entries.

Parameter	Description
<code>grouplist<UID></code>	Retrieves a list of sites and groups in the specified group.
<code>grouplist<UID></code> <code><search string></code>	Retrieves directories that match the string inside of the specified group.
<code>range</code>	Returns directory entries in the range specified.
<code>"start_no"</code>	Specifies the beginning of the range of entries to return.
<code>"stop_no"</code>	Specifies the end of the range of entries to return.

Feedback Examples

- `localdir sd 5`

returns

```
localdir 0. SD-Austin-01@polycom.com:
local#840780b28ef4234f84f64298909aca07:site
localdir 1. SD-Austin-02@polycom.com:
local#8852f4c7cb6d9b4fab7e53e2730a5219:site
localdir 2. SD-Dallas-01@polycom.com:
local#83840767145bf04a9ce2b307af6d5688:site
localdir 3. SD-Dallas-02@polycom.com:
local#158aa86dd780ca4f8731fcfd627e05ad:site
localdir 4. SD-Houston-01@polycom.com:
local#e2859e0318bca145ba9b6f641e7f39d2:site
localdir 5. SD-Houston-02@polycom.com:
local#f82be96eea3bd644a1963dc7fdf45011:site
localdir sd 5 done
```

- `localdir entry ldap#g#8852f4c7cb6d9b4fab7e53e2730a5219`

returns

```
localdir 0. "SD-Austin-02@polycom.com" sip_spd:Auto sip_num:sip:SEA18-09.106avtc.
localdir 1. "SD-Austin-02@polycom.com" h323_spd:Auto h323_num: h323_ext:12067406489
localdir entry ldap#g#8852f4c7cb6d9b4fab7e53e2730a5219 done
```

- `localdir grouplist`

returns

```
localdir 0. Admin Admin:ldap#g#589feda2e097073b52134c7984ca6b44:site
localdir 1. Admin2 Admin2:ldap#g#e6b660a112b25d4cb2067243e73da458:site
localdir 2. G7500:ldap#g#0410894cfa213c418df5bd1226d46491:group
localdir 3. Group Series:ldap#g#011d8db58de14d48838549c5e0ec7465:group
localdir 4. HDX_MISC:ldap#g#2331576d60cf9948a09860946f38a42b:grouplocaldir 5. Sam
localdir 6. Sams Saturn:ldap#g#5cb47f04e402d7478631ad45b5e6b493:site
localdir grouplist done
```

Limitations

None

Comments

None

importprofile

Imports system and user profile information in a CSV format.

Syntax

```
importprofile
<import data line 1>
<import data line 2>
<import data line 3>
. . .
importcomplete
```

Additional Restrictions

None

Feedback Examples

- `importprofile`
returns
`import started`
`profileversion,0.2`
`system.info.eulafile,eula`
`system.info.hardwareversion,9`
`system.info.humanreadablemodel,RealPresence Group 500`
`system.info.humanreadableplatform,GROUPSERIES`
`system.info.humanreadableversion,Dev - 4.1.3-0`
`system.info.plcmstandardversion,Dev - 4.1.3-0`
`system.info.serialnumber,8213130FE433CV`
`audio.lineIO.lineinechocanceller,"False"`
`audio.volume.speakervolume,"46"`
`comm.Firewall.fixedportstcphigh,"3241"`
`comm.Firewall.fixedportsudphigh,"3301"`
`comm.NICs.H323Nic.h323extension,"177704997"m`
`comm.NICs.H323Nic.h323name,"G7500 177704997"`

```

comm.NICs.SipNic.bfcptransportprotocol,"Prefer_UDP"
comm.NICs.SipNic.thirdpartyinterop.ocs.sipuuid,"d503b976-c62f-5484-82c0-6 4a47963
comm.Qos.tos.tosaudio,"5"
comm.Qos.tos.tosfecc,"3"
comm.Qos.tos.tosoam,"0"
comm.Qos.tos.tosvideo,"4"
location.country,"United States"
location.language,"ENGLISHUS"
pm.monRoleAuto,"True"
pm.monitor[1].enable,"True"
softupdate.url,"http://builds.softupdate.com/~test/softupdate /"
sourceman.camera[1].autowhitebalancegainb,"33"
sourceman.camera[1].autowhitebalancegainr,"37"
sourceman.camera[1].backlightcomp,"False"
sourceman.camera[1].brightness,"11"
sourceman.camera[1].contrast,"13"
sourceman.camera[1].name,"Main"
sourceman.camera[1].role,"People"
sourceman.camera[1].saturation,"6"
sourceman.camera[1].sharpness,"3"
sourceman.camera[1].videoquality,"Sharpness"
sourceman.camera[1].whitebalancemode,"atw"
video.monitor[1].Resolution,"1920x1080p 60Hz"
video.monitor[2].Resolution,"1920x1080p 60Hz"

importcomplete

importprofile succeeded

```

Limitations

None

Comments

When importing profile data, the imported data must be in the same format as was obtained from the system using the exportprofile command. When importing profile data back into the system, use the data in its entirety (not edited in any form). The system may use the checksum utility to verify of integrity of the data when it is imported.

importprofile done indicates that all the profile data has been imported.

A restart of the system is required after successfully importing system and user profile information.

You must include the importcomplete command as the last entry. Issuing the importcomplete command on its own line indicates that the profile import is complete. If no data is received for 60 seconds during import, the import ends, and an importprofile timed out error response displays. All previous data entered is ignored.

The system might not allow certain parameters, such as passwords or software build information, to be updated during the import process (logs messages indicate if a parameter is ignored).

Exporting a profile on one system model and importing the profile on another model is not supported. Attempts to export and import profile information between different systems might also fail. The message importprofile failed indicates that the system was not able to import the information.

See Also

See the exportprofile command.

Content sharing APIs

- [content](#)
Controls video content by showing, hiding, or closing shared content.
- [contentauto](#)
Gets or sets the automatic bandwidth adjustment for people and content in point-to-point H.323 calls. Automatic adjustment maintains equal image quality in the two streams.
- [content list](#)
Displays a list containing information on system content status.
- [vcbutton](#)
Controls HDMI content video source. It can also register or unregister the API session to receive notification of HDMI and far end (in a call) content events.

content

Controls video content by showing, hiding, or closing shared content.

Syntax

```
content show <ID>
content hide <ID>
content close <ID>
```

Table 1.

Parameter	Description
show	If content is hidden in the content tray, starts showing specific content by <ID>.
hide	Hides specific displayed content in the content tray by <ID>. Use <code>all</code> in place of the <ID> to hide all active content in the content tray.
close	Closes specific content source by <ID>.

Feedback Examples

- `content show 987`
returns
`content show successful`
- `content hide 987`
returns
`content hide successful`
- `content hide all`
returns
`content hide all successful`
- `content close 987`
returns
`content close successful`
- `content show 115`
returns
`error: input 115 is not a content source content show failed`

Limitations

You can't close some content sources, only hide them. For example, HDMI content.

Comments

If you try to call `content show` for content already shown or `content hide` for content already hidden, the system

returns

`"error: not allowed"`.

contentauto

Gets or sets the automatic bandwidth adjustment for people and content in point-to-point H.323 calls. Automatic adjustment maintains equal image quality in the two streams.

Syntax

`contentauto <get|on|off>`

Table 1.

Parameter	Description
get	Returns the current setting.
on	Enables automatic bandwidth adjustment for people and content.
off	Disables automatic bandwidth adjustment for people and content. The Quality Preference setting is used instead.

Feedback Examples

- `contentauto off`
returns
`contentauto off`
- `contentauto on`
returns
`contentauto on`
- `contentauto get`
returns
`contentauto on`

Limitations

None

Comments

None

content list

Displays a list containing information on system content status.

Syntax

```
content list  
content list <type|ID>
```

content list shown
content list hidden

Table 1.

Parameter	Description
contentlist	Returns all content.
type	Returns all content of a given type. Type values are: UNKNOWN, CONTENTCAM, PPCIP, MIRACAST, AIRPLAY, D
ID	Returns all content with a given source ID.
shown	Returns content this is displaying on your system.
hidden	Returns content that is hidden in the content tray.

Feedback Examples

- content list
returns
content list start content: id:"id" name:"name" type:"source type"
shown:true/false content list done
- content list shown
returns
content list start content: name: id:"123456" "Blackboard-1"
type:"drawingboard" shown:true content list done
- content list contentcam
returns
content list start content: name: id:"1234" "HDMI" type:"contentcam"
shown:true content list done
- content list 12347
returns
content list start content: name: id:"12347" "My iphone"
type:"airplay" shown:false content list done

Limitations

None

Comments

The system returns an empty list if the filter doesn't match a source.

vcbutton

Controls HDMI content video source. It can also register or unregister the API session to receive notification of HDMI and far end (in a call) content events.

Syntax

```
vcbutton play {2}  
vcbutton <get|stop|register|unregister>  
vcbutton source get
```

Table 1.

Parameter	Description
get	Returns the current setting of HDMI content (play or stop).
play	Starts sending the content from the HDMI content video source. If no content video source is specified, starts sending content from content source 2 HDMI input. Starts content from HDMI content video source without needing to stop the currently playing content video source. Fails and doesn't stop the current content video source if the specified HDMI content video source isn't valid. Note: Source 2 (HDMI in) is only supported.
stop	Stops sending HDMI content that is currently playing.
register	Registers the API session to receive notifications about HDMI content and content events shared from far end in a call.

Parameter	Description
<code>unregister</code>	Unregisters the API session to receive notifications about HDMI content and content events shared from far end in a call.
<code>source get</code>	Gets the HDMI content video source that is currently playing.

Feedback Examples

- If not registered for notifications:`vbutton play`
returns
`vbutton play vbutton play succeeded`
- If registered for notifications:`vbutton play`
returns
Control event: `vbutton play vbutton play vbutton play succeeded`
control event: `vbutton source 2`
- `vbutton play 1`
returns
error: `input 1 is not a content source vbutton play failed`
- `vbutton play` (HDMI content is already active) returns `info: active`
- `vbutton stop`
returns
Control event: `vbutton stop vbutton stop vbutton stop succeeded`
- `vbutton get`
returns
`vbutton stop vbutton get succeeded`
- `vbutton source get` (HDMI content is inactive) returns `vbutton source get none`
`vbutton source get succeeded`
- `vbutton source get` (HDMI content is active) returns `vbutton source get 2`
`vbutton source get succeeded`

Limitations

`vbutton` supports only control of HDMI content and notifications related to HDMI and far end content in a

call.

Comments

None

General APIs

- [apiport](#)
Gets or sets the command-line API telnet port.
- [exportprofile](#)
Exports system and user profile information in CSV format. The output is available through a telnet or serial port connection.
- [exit](#)
Ends the command-line API session.
- [listen](#)
Registers the API session to listen for the following events and statuses: incoming video calls, system sleep/awake state, and notifications when the registered state occurs.
- [loglevel](#)
Gets or sets the minimum log level of messages stored in the system's flash memory.
- [notify](#)
Lists the types of notifications being received or registers to receive status notifications.
- [nonotify](#)
Unregisters the API client to receive status notifications.
- [powerdown](#)
Restarts the system and disconnects the API connection.
- [providermode](#)
Reports the current provider and lock state or sets the provider.
- [oobcomplete](#)
Completes the onscreen setup instructions and restarts the system.
- [reboot](#)
Restarts the system.
- [resetsettings](#)
Resets your system to default settings. Nothing is retained during the reset if you do not include at least one of the following parameters.
- [sleep](#)
Gets or sets options for system sleep mode.
- [sleeptime](#)
Gets or sets the time before the system goes to sleep.
- [amxdd](#)

Gets or sets the AMX Device Discovery beacon.

- **serialnum**

Returns the serial number of the system.

- **session**

Names or finds an active API session.

- **status**

Returns the current status of devices and primary system services.

- **systemname**

Gets or sets the name of the system.

- **uptime**

Returns the total time the system has been running since the last system start.

- **version**

Returns the current system's version information.

- **wake**

Wakes the system from sleep mode.

- **whoami**

Displays the same initial banner information when an API session starts.

apiport

Gets or sets the command-line API telnet port.

Syntax

```
apiport get  
apiport <23|24>
```

Table 1.

Parameter	Description
get	Returns the configured command-line API port.
23	Sets the command-line API telnet port to 23.
24	Sets the command-line API telnet port to 24. Default setting.

Feedback examples

- `apiport get`
returns
`apiport 24`
- `apiport 23`
returns
`apiport 23`

Limitations

None

Comments

After sending the command to change the port, you must exit the current session and reconnect on the new port.

exportprofile

Exports system and user profile information in CSV format. The output is available through a telnet or serial port connection.

Syntax

`exportprofile`

Additional Restrictions

None

Feedback Examples

- `exportprofile`
returns
`exportprofile started`
`profileversion,0.2`
`system.info.eulafile,eula`
`system.info.hardwareversion,9`
`system.info.humanreadablemodel,RealPresence`
`system.info.humanreadableplatform,`
`system.info.humanreadableversion,Dev - 4.1.3-0`
`system.info.plcmstandardversion,Dev - 4.1.3-0`
`system.info.serialnumber,8213130FE433CV`
`audio.lineIO.lineinechocanceller,"False"`
`audio.volume.speakervolume,"46"`
`comm.Firewall.fixedportstcphigh,"3241"`
`comm.Firewall.fixedportsudphigh,"3301"`
`comm.NICs.H323Nic.h323extension,"177704997" comm.NICs.H323Nic.h323name,"177704997`
`comm.NICs.SipNic.bfcpttransportprotocol,"Prefer_UDP"`
`comm.NICs.SipNic.thirdpartyinterop.ocs.sipuuid,"d503b976-c62f-5484-82c0-64a479`

```
63 18d1"
comm.Qos.tos.tosaudio,"5" comm.Qos.tos.tosfecc,"3"
comm.Qos.tos.tosoam,"0"
comm.Qos.tos.tosvideo,"4"
location.country,"United States"
location.language,"ENGLISHUS"
pm.monRoleAuto,"True"
pm.monitor[1].enable,"True"
softupdate.url,"http://builds.softupdate.com/~test/softupdate /"
sourceman.camera[1].autowhitebalancegainb,"33"
sourceman.camera[1].autowhitebalancegainr,"37"
sourceman.camera[1].backlightcomp,"False"
sourceman.camera[1].brightness,"11"
sourceman.camera[1].contrast,"13"
sourceman.camera[1].name,"Main"
sourceman.camera[1].role,"People"
sourceman.camera[1].saturation,"6"
sourceman.camera[1].sharpness,"3"
sourceman.camera[1].videoquality,"Sharpness"
sourceman.camera[1].whitebalancemode,"atw"
video.monitor[1].Resolution,"1920x1080p 60Hz"
video.monitor[2].Resolution,"1920x1080p 60Hz"
exportprofile done
```

Comments

exportprofile done indicates that all profile data is exported.

When importing directory data back into the system, use the data in its entirety (not edited in any form). There is information that is used by the system to determine what type data (XML or CSV) is being imported.

See Also

See the [importprofile](#) command.

exit

Ends the command-line API session.

Syntax

```
exit
```

Feedback Examples

- `exit`
returns
Connection to host lost.

Limitations

None

Comments

For serial sessions, this command starts a new session.

listen

Registers the API session to listen for the following events and statuses: incoming video calls, system sleep/awake state, and notifications when the registered state occurs.

Syntax

```
listen <video|sleep>
```

Table 1.

Parameter	Description
video	Instructs the session to listen for incoming video calls. When this event occurs, the message <code>listen video ringing</code> is received.
sleep	Instructs the session to listen for when the system goes into sleep mode. When this event occurs, the message “ <code>listengoing to sleep</code> ” is received. When the system wakes up, the message “ <code>listen waking up</code> ” is received. Deprecated. Poly recommends using <code>sleep register</code> instead of this command.

Feedback Examples

- `listen sleep`
returns
`listen sleep registered`
to acknowledge that the session is now registered to listen for sleep mode
- `listen video`
returns
- returns `listen video registered`
to acknowledge that the session is now registered to listen for incoming video calls

Limitations

None

Comments

None

loglevel

Gets or sets the minimum log level of messages stored in the system's flash memory.

Syntax

```
loglevel get  
loglevel set <debug|info|warning|error|critical>
```

Table 1.

Parameter	Description
get	Returns the current setting.
set	Sets the debug level.
debug	Sets debug level to log all messages. The default.
info	Sets debug level to log all informational messages.
warning	Sets debug level to log all informational and warning messages.
error	Sets debug level to log all informational, warning, and error messages.
critical	Sets debug level to log all informational, warning, error, and critical messages.

Feedback Examples

- `loglevel get`

```

returns
loglevel info

```

- `loglevel set warning`

```

returns
loglevel warning

```
- `loglevel set error`

```

returns
loglevel error

```

Limitations

None

Comments

warning logs the fewest number of messages.

Poly recommends leaving this setting at the default value of debug.

notify

Lists the types of notifications being received or registers to receive status notifications.

Syntax

```

notify
notify <callstatus|linestatus|mutestatus|screenchanges>
notify <sysstatus|sysalerts|vidsourcechanges>
notify calendarmeetings

```

Table 1.

Parameter	Description
<code>notify</code>	Lists the notification types that are being received in the following format: <code>registeredfor <num> notifications[:notification t</code>
<code>calendarmeetings</code>	Registers the API client to receive meeting reminders.

Parameter	Description
callstatus	<p>Registers the system to receive changes in call status, such as a connection or disconnection in the following format:</p> <p>notification:callstatus:<call direction>:<call</p>
linestatus	<p>Registers the system to receive line status notifications as they occur in the following format:</p> <p>notification:linestatus:<direction>: <callid>:<line id>:<channel id>: <connectionstatus></p>
mutestatus	<p>Registers the system to receive changes in audio mute status in the following format:</p> <p>notification:mutestatus:<nearor far>:<call id>:<</p>
screenchanges	<p>Registers the system to receive notification when a user interface screen is displayed in the following format:</p> <p>notification:screenchange:<screenname>:<screen o</p>
sysstatus	<p>Registers the system to receive system status notifications in the following format:</p> <p>notification:sysstatus:<sysparameter name>:<value1>[:<value2>...]</p>
sysalerts	<p>Registers the system to receive system alerts in the following format:</p> <p>notification:sysalert:<alert name>:<value1>[:<value2>...]</p>
vidsourcechanges	<p>Registers the system to receive notification of camera source changes in the following format:</p> <p>notification:vidsourcechange:<nearor far>:<camer</p>

Feedback Examples

- `notify mutestatus`
returns
`notify mutestatus success`
acknowledging that the session is registered to receive mutestatus notifications
- `notify callstatus`
returns
`notify callstatus success`
acknowledging that the session is registered to receive callstatus notifications
- If entered again,
`notify callstatus`
returns
`info: event/notification already active:callstatus`
- `notify`
returns
`registered for 2 notifications:callstatus:mutestatus`
- `notify calendarmeetings`
returns
`notify calendarmeetings success`

The following are examples of notifications that may be returned after registering to receive them.

- `notification:callstatus:outgoing:34:PolycomG7500
Demo:192.168.1.101:connected:384:0:videocall`
- `notification:mutestatus:near:near:near:near:muted`
- `notification:screenchange:systemsetup:systemsetup_a`
- `notification:vidsourcechange:near:1:Main:people`
- `notification:linestatus:outgoing:32:0:0:disconnected`
- `notification:vidsourcechange:near:none:none:content`
- `notification: calendarmeetings:
AAAaAEFsZXguTWFjRG9uYWxkQHBvbH1jb20uY29tAVEACIjMne2/ndgARgAAAADr9G1hsSjWE ZBcAAKz`

Limitations

None

Comments

The `notify callstatus` command registers the current API session for call status notifications. The API client receives call status notifications as a call progresses.

Registration for status notifications is session-specific. For example, registering for alerts in a Telnet session does not return alerts in a simultaneous RS-232 session with the same system.

Duplicate registrations produce another success response. The notify setting remains in effect, even if you restart the system or update the software with system settings saved.

See Also

See also the [nonotify](#) command and the [callinfo](#) command.

nonotify

Unregisters the API client to receive status notifications.

Syntax

```
nonotify <callstatus|linestatus|mutestatus|screenchanges>  
nonotify <sysstatus|sysalerts|vidsourcechanges>
```

Table 1.

Parameter	Description
calendarmeetings	Stops the system from receiving meeting reminders.
callstatus	Stops the system from receiving changes in call status, such as a connection or disconnection.
linestatus	Stops the system from receiving line status notifications.
mutestatus	Stops the system from receiving changes in audio mute status.
screenchanges	Stops the system from receiving notification when a user interface screen is displayed.
sysstatus	Stops the system from receiving system status notifications.
sysalerts	Stops the system from receiving system alerts.

Parameter	Description
<code>vidsourcechanges</code>	Stops the system from receiving notification of camera source changes.

Feedback Examples

- `nonotify callstatus`
returns
`nonotify callstatus success`
- If entered again,
`nonotify callstatus`
returns
`info: event/notification not active:callstatus`
- `nonotify calendarmeetings`
returns
`nonotify calendarmeetings success`

Limitations

None

Comments

None

See Also

See the related [notify](#) command.

powerdown

Restarts the system and disconnects the API connection.

The `powerdown` command doesn't prompt the user to confirm and restarts the system with no other feedback returned. After the system restarts, it's available for use again.

Note	There is no capability to fully power off the device, it can only be restarted using this command.
-------------	--

Syntax

`powerdown`

Table 1.

Parameter	Description
powerdown	Restarts the system.

Feedback Examples

- powerdown
returns
powerdown

Limitations

None

Comments

None

providermode

Reports the current provider and lock state or sets the provider.

Syntax

```
providermode get
providermode set <Zoom | Teams| LogMeIn| BlueJeans | RingCentral| PolyVideo | Poly| co
```

Table 1.

Parameter	Description
get	Reports the current provider and the provider lock state.
set	Sets the provider.
Zoom	Sets the provider to Zoom Rooms.
Teams	Sets the provider to Microsoft Teams Rooms.

Parameter	Description
LogMeIn	Sets the provider to LogMeIn.
BlueJeans	Sets the provider to BlueJeans.
RingCentral	Sets the provider to RingCentral.
Poly	Sets the provider to Poly Video Mode.
camuvc	Sets the provider to Device Mode.
StarLeaf	Sets the provider to StarLeaf.

Feedback Examples

- `providermode get`
returns
`provider <Zoom | Teams | etc> lockstate: <locked | unlocked>`

The command `providermode set <provider name>`

returns

returns

one of four status values

- `provider already set. No need to change.`
- `provider change succeeded.`
- `provider change failed: current provider:{provider name}`
- `provider change failed: provider locked`

If a reboot is required after setting the provider, the command returns

- `Rebooting..`

- `provider set Zoom`
returns
Provider change succeeded.
Rebooting..

Limitations

None

Comments

None

oobcomplete

Completes the onscreen setup instructions and restarts the system.

Syntax

`oobcomplete`

Feedback Examples

- `oobcomplete`
returns
`oobcomplete`

Limitations

None

Comments

The `oobcomplete` command is processed only when the system is in setup mode. To execute `oobcomplete` successfully, the system name must be configured.

reboot

Restarts the system.

Syntax

`reboot [now]`

Table 1.

Parameter	Description
now	Restarts the system without prompting you.

Feedback Examples

reboot now

Limitations

None

Comments

None

resetsettings

Resets your system to default settings. Nothing is retained during the reset if you do not include at least one of the following parameters.

Syntax

```
resetsettings <keepcertificates|keeplocaldirectory|keepcdr|keeplogs>
```

Table 1.

Parameter	Description
keepcertificates	Resets your system settings but keeps installed PKI certificates.
keeplocaldirectory	Resets your system settings but keeps local directory entries.
keepcdr	Resets your system settings but keeps the call detail report (CDR).
keeplogs	Resets your system settings but keeps system logs.

Feedback Examples

- `resetsettings`
returns
`resetsettings, are you sure? <y,n>`
- `resetsettings keepcertificates`
returns
`resetsettings, are you sure? <y,n>`

Limitations

None

Comments

None

sleep

Gets or sets options for system sleep mode.

Syntax

```
sleep  
sleep <register|unregister>  
sleep mute <get|on|off>
```

Table 1.

Parameter	Description
get	Returns the current setting for the sleep mute command.
on .	Mutes the system microphone while the system is in sleep mode
off	Unmutes the microphone while the system is in sleep mode.
mute	Mutes the system microphone while the system is in sleep mode.

Parameter	Description
sleep	Puts the system in sleep mode if not followed by other parameters.
register	Registers the system for sleep or wake events.
unregister	Unregisters the system for sleep or wake events.

Feedback Examples

- sleep
returns
sleep
- sleep register
returns
sleep registered
- If entered again,sleep register
returns
info: event/notification already active:sleep
- sleep unregister
returns
sleep unregistered
- If entered again,sleep unregister
returns
info: event/notification not active:sleep
- sleep mute get
returns
sleep mute off
- sleep mute on
returns
sleep mute on

Limitations

None

Comments

None

sleeptime

Gets or sets the time before the system goes to sleep.

Syntax

```
sleeptime <get|0|1|3|15|30|60|120|240|480>
```

Table 1.

Parameter	Description
get	Returns the current setting.
off 1 3 15 30 45 60 120 240 480	Sets the number of minutes from last user interaction to entering sleep mode. The default value is 3. A value of 0 indicates that the system will never go to sleep.

Feedback Examples

- ```
sleeptime 30
```

```
returns
```

```
sleeptime 30
```

Limitations

None

Comments

None

## ***amxdd***

Gets or sets the AMX Device Discovery beacon.

Syntax

```
amxdd get
amxdd <on|off>
```

Table 1.

| Parameter | Description                                |
|-----------|--------------------------------------------|
| get       | Returns the current setting.               |
| on        | Turns on the AMX Device Discovery beacon.  |
| off       | Turns off the AMX Device Discovery beacon. |

#### Feedback examples

- amxdd get  
returns  
amxdd off
- amxdd on  
returns  
amxdd on

#### Limitations

None

#### Comments

The default setting for this signal is off.

## **serialnum**

Returns the serial number of the system.

#### Syntax

```
serialnum
```

#### Feedback Examples

- serialnum  
returns

serialnum 82065205E72E1

Limitations

None

Comments

None

## **session**

Names or finds an active API session.

Syntax

```
session name "session-name"
session find "session-name"
```

Table 1.

| Parameter    | Description                                  |
|--------------|----------------------------------------------|
| name         | Names the current API session.               |
| find         | Finds an active API session for this system. |
| session-name | Unique string that identifies the session.   |

Feedback Examples

- session name sessionone  
returns  
session name sessionone success
- If entered again, session name sessionone  
returns  
info: the supplied session name is already in use session name  
sessionone failed
- session find sessionone  
returns  
info: session sessionone attached

- `session find sessiontwo`  
returns  
`info: session sessiontwo not connected`

Limitations

None

Comments

None

## **status**

Returns the current status of devices and primary system services.

Syntax

`status`

Table 1.

| Parameter           | Description                                    |
|---------------------|------------------------------------------------|
| <code>status</code> | Returns the current status of system settings. |

Feedback Examples

- `status`  
returns  
`inacall offline autoanswerp2p online remotecontrol online microphones  
online globaldirectory offline ipnetwork online gatekeeper online  
sipserver online calendar online logthreshold offline provisioning  
online wifi offline status end`

Limitations

None

Comments

None

## **systemname**

Gets or sets the name of the system.

## Syntax

```
systemname get
systemname set "system name"
```

Table 1.

| Parameter     | Description                                                                                                                                                                                                                                                                                                                                         |
|---------------|-----------------------------------------------------------------------------------------------------------------------------------------------------------------------------------------------------------------------------------------------------------------------------------------------------------------------------------------------------|
| get           | Returns the current setting.                                                                                                                                                                                                                                                                                                                        |
| set           | Sets the system name to "system name".                                                                                                                                                                                                                                                                                                              |
| "system name" | <p>Character string specifying the system name. Enclose the string in quotation marks if it includes spaces.</p> <p>Example: "Polycom G7500 Demo"</p> <p>Up to 40 ASCII characters are supported.</p> <p>No foreign language characters are allowed. If foreign characters are required, change the system name using the system web interface.</p> |

## Feedback Examples

- systemname set "Demo"  
returns  
systemname "Demo"
- systemname set get  
returns  
systemname "Demo"

## Limitations

None

## Comments

None

## ***uptime***

Returns the total time the system has been running since the last system start.

Syntax

```
uptime get
```

Table 1.

| Parameter | Description                  |
|-----------|------------------------------|
| get       | Returns the current setting. |

Feedback Examples

- ```
uptime get
```

```
returns
```

```
1 Hour, 10 Minutes
```

Limitations

None

Comments

None

version

Returns the current system's version information.

Syntax

```
version
```

Additional Restrictions

None

Feedback Examples

- ```
version
```

```
returns
```

```
version 2.0
```

Limitations



None

Comments

None

## **wake**

Wakes the system from sleep mode.

Syntax

wake

Additional Restrictions

None

Feedback Examples

- wake  
returns  
wake, and wakes the system from sleep mode

Limitations

None

Comments

None

See Also

To put the system in sleep mode, use the [sleep](#) command.

## **whoami**

Displays the same initial banner information when an API session starts.

Syntax

whoami

Additional Restrictions

None

Feedback Examples

- `whoami`

returns

```
Hi, my name is: Demo Here is what I know about myself: Model: Serial
Number: 82065205E72E1 Software Version: 1.0 Build Information: root on
domain.polycom.com Time In Last Call: 01:43:50 Total Time In Calls: 3
days, 08:17:17 Total Calls: 819 SNTP Time Service: auto insync
ntp1.polycom.com Local Time is: Wed, 30 Nov 2008 10:41:46 Network
Interface: NONE IP Video Number: 192.168.1.101 MP Enabled:
AB1C-2D34-5EF6-7890-GHI1 H323 Enabled: True HTTP Enabled: True SNMP
Enabled: True
```

Limitations

None

Comments

The response can vary depending on your system configuration.

## **Network APIs**

- [defaultgateway](#)  
Gets or sets the default gateway.
- [dhcp](#)  
Gets or sets DHCP options.
- [echo](#)  
Returns a string that is sent to the system.
- [echoreply](#)  
Gets or sets the system's ability to send an Echo Reply message in response to an Echo Request message sent to an IPv4 multicast/anycast address.
- [dns](#)  
Gets or sets the configuration for up to four DNS servers.
- [enablefirewalltraversal](#)  
Gets or sets the system's ability to traverse firewalls. This feature requires a session border controller that supports H.460.
- [advnetstats](#)  
Gets advanced network statistics for a call connection.
- [dynamicbandwidth](#)  
Gets or sets the use of dynamic bandwidth allocation for Quality of Service.
- [e164ext](#)  
Gets or sets an H.323 (IP) extension (also known as an E.164 name).
- [daylightsavings](#)

Gets or sets the daylight saving time setting. When you enable this setting, the system clock automatically changes for daylight saving time.

- [enablepvec](#)

Gets or sets the Polycom Video Error Concealment (PVEC) setting on the system.

- [enablesipka](#)

Gets or sets the option to send SIP keep-alive messages.

- [enablesnmp](#)

Gets or enables/disables SNMP.

- [gatekeeperip](#)

Gets or sets the IP address of the H.323 gatekeeper.

- [h323authenticateenable](#)

Enables or disables H.323 authentication.

- [h323authenticatename](#)

Sets the H.323 name to use to identify the system.

- [h323authenticatepassword](#)

Sets the password for H.323 authentication.

- [h323name](#)

Gets or sets the system's H.323 name.

- [getconfiguredipaddress](#)

Retrieves the currently configured IPv4 address from the system.

- [hostname](#)

Gets or sets the LAN host name, which is assigned to the system for TCP/IP configuration and can be used in place of an IP address when dialing IP calls.

- [ipaddress](#)

Gets or sets the LAN IP address (IPv4) of the system.

- [lanport](#)

Gets or sets the LAN port settings of the system.

- [ldapauthenticationtype](#)

Gets or sets the authentication type required to authenticate with an LDAP server.

- [ldapbasedn](#)

Gets or sets the base distinguished name (DN) of an LDAP server.

- [ldapbinddn](#)

Gets or sets the bind DN for LDAP Simple Authentication.

- [ldapdirectory](#)

Gets or sets the LDAP directory server setting.

- [ldapntlm domain](#)

Gets or sets the domain in which authentication takes place in the LDAP server.

- [ldappassword](#)

Sets the password for Simple or NT LAN Manager (NTLM) authentication of an LDAP server.

- [ldapsrveraddress](#)

Gets or sets the LDAP server address.

- [ldapsrverport](#)

Gets or sets the port number of an LDAP server.

- [ldapsslenabled](#)

Gets or sets the Transport Layer Security (TLS) encryption state for LDAP operations.

- [ldapusername](#)

Gets or sets the user name for NTLM authentication of an LDAP server.

- [natconfig](#)

Gets or sets the NAT configuration.

- [nearloop](#)

Activates or deactivates the Near End Loop test.

- [netstats](#)

Returns network statistics for each call connection.

- [nath323compatible](#)

Gets or sets whether the NAT is H.323 compatible.

- [ntpmode](#)

Sets the Network Time Protocol (NTP) server mode, which determines how the system connects to the time server to obtain time settings.

- [ntpsecondaryserver](#)

Sets the NTP server to use for time settings when the primary time server does not respond.

- [ntpserver](#)

Sets the NTP server to use for time settings when the time server is set to manual.

- [rs232 baud](#)

Gets or sets the baud rate for the first RS-232 port.

- [rs232 mode](#)

Gets or sets the operational mode of the system's serial port.

- [rs232login](#)

Gets or sets the serial port login requirements.

- [snmpadmin](#)

Gets or sets your SNMP support contact name.

- [snmpcommunity](#)

Gets or sets the SNMP community string.

- [snmpconsoleip](#)

Gets or sets the SNMP console IP address.

- [snmplocation](#)

Gets or sets the location of the SNMP system.

- [snmpnotification](#)  
Enables or disables SNMP notifications for the Poly MIB, which can be downloaded from the SNMP page in the system web interface.
- [snmpsystemdescription](#)  
Gets or sets the SNMP system description.
- [snmptrapversion](#)  
Gets or sets the SNMP trap version.
- [subnetmask](#)  
Gets or sets the subnet mask of the system.
- [usegatekeeper](#)  
Gets or sets whether the system can use an H.323 gatekeeper.
- [wanipaddress](#)  
Gets or sets the WAN IP address.

## ***defaultgateway***

Gets or sets the default gateway.

Syntax

```
defaultgateway get
defaultgateway set "xxx.xxx.xxx.xxx"
```

Table 1.

| Parameter         | Description                                                                |
|-------------------|----------------------------------------------------------------------------|
| get               | Returns the default gateway IP address.                                    |
| set               | Sets the default gateway when followed by the "xxx.xxx.xxx.xxx" parameter. |
| "xxx.xxx.xxx.xxx" | IP address to use as the default gateway.                                  |

Feedback Examples

- ```
defaultgateway set 192.168.1.101
returns
defaultgateway 192.168.1.101
```

Limitations

None

Comments

You can only change the defaultgateway setting if DHCP is turned off.

dhcp

Gets or sets DHCP options.

Syntax

```
dhcp <get|off|client>
```

Table 1.

Parameter	Description
get	Returns the selected DHCP option.
off	Disables DHCP.
client	Enables DHCP client. The system obtains an IP address from a server on your network.

Feedback Examples

- `dhcp off`
returns
`dhcp off`
- `dhcp client`
returns
`dhcp client`
- `dhcp get`
returns
`dhcp get`

Limitations

None

Comments

You must restart the system after making a change to a setting.

echo

Returns a string that is sent to the system.

Syntax

```
echo <string>
```

Table 1.

Parameter	Description
echo<string>	Returns a string sent to the system.

Feedback Examples

- echo "Are you there?"
returns
Are you there?
- returns
- echo KA
returns
KA

Limitations

None

Comments

None

echoreply

Gets or sets the system's ability to send an Echo Reply message in response to an Echo Request message sent to an IPv4 multicast/anycast address.

Syntax

```
echoreply <get|yes|no>
```

Table 1.

Parameter	Description
get	Returns the current setting.
yes	Enables the echo reply option.
no	Disables the echo reply option.

Feedback Examples

- echoreply get
returns
echoreply yes
- echoreply no
returns
echoreply no

Limitations

None

Comments

The number of responses may be traffic-conditioned to limit the effect of a denial-of-service (DoS) attack. You must restart the system after making a change to a setting.

dns

Gets or sets the configuration for up to four DNS servers.

Syntax

```
dns get {1..4}
dns set {1..4} "xxx.xxx.xxx.xxx"
```

Table 1.

Parameter	Description
get	Returns the current IP address of the specified server. A server identification number {1..4} is required.
{1..4}	Specifies the server identification number.
set	Sets the IP address of the specified DNS server when followed by the "xxx.xxx.xxx.xxx" parameter. A server identification number {1..4} is required.
"xxx.xxx.xxx.xxx"	Specifies the IP address for the specified server.

Feedback Examples

- `dns set 1 192.168.1.205`
returns
`dns 1 192.168.1.205`

Limitations

None

Comments

After making a change, you must restart the system for the setting to take effect.

You cannot set these values if the system is in DHCP client mode.

enablefirewalltraversal

Gets or sets the system's ability to traverse firewalls. This feature requires a session border controller that supports H.460.

Syntax

```
enablefirewalltraversal <get|on|off>
```

Table 1.

Parameter	Description
get	Returns the current setting.
on	Enables the firewall traversal feature.
off	Disables the firewall traversal feature.

Feedback Examples

- enablefirewalltraversal on
returns
enablefirewalltraversal on
- enablefirewalltraversal off
returns
enablefirewalltraversal off
- enablefirewalltraversal get
returns
enablefirewalltraversal off

Limitations

None

Comments

None

advnetstats

Gets advanced network statistics for a call connection.

Syntax

```
advnetstats [{0..n}]
```

Table 1.

Parameter	Description
{0..n}	Specifies a connection in a call, where nis the maximum number of connections supported by the system. 0is call #1, 1is call #2, 2is call #3, and so on. Select a number from this range to specify a remote site call for which you want to obtain advanced network statistics. Omit this parameter when retrieving statistics for a point-to-point call.

Feedback examples

```
advnetstats0
```

returns

```
call:0 tar:96 K rar:96 K tvr:224 K rvr:416 K
tvru:219 K rvru:154 K tvfr:29 rvfr:26 vfe:0
tapl:0 rapl:0 taj:6 ms raj:5 ms
tvpl:0 rvpl:0 tvj:6 ms rvj:11 ms
dc:Disabled rsid:Sams RP700 ccaps:9
tcr:0 rcr:128 K tcru:0 rcru:128k
tcfr:0 rcfr:64 K tcpl:0 rcpl:0
```

where:

```
tar = transmit audio rate
rar = receive audio rate
tvr = transmit video rate
rvr = receive video rate
tvru = transmit video rate used
rvru = receive video rate used
tvfr = transmit video frame rate
rvfr = receive video frame rate
vfe = video FEC errors
tapl = transmit audio packet loss (H.323 calls only)
tlspd = transmit LSD protocol (H.320 calls only)
rapl = receive audio packet loss (H.323 calls only)
rlspd = receive LSD protocol (H.320 calls only)
taj = transmit audio
jitter (H.323 calls only)
tlsdr = transmit LSD rate (H.320 calls only)
raj = receive audio jitter (H.323 calls only)
rlsd = receive LSD rate (H.320 calls only)
tvpl = transmit video packet loss (H.323 calls only)
tmlpp = transmit MLP protocol (H.320 calls only)
rvpl = receive video packet loss (H.323 calls only)
rmlpp = receive MLP protocol (H.320 calls only)
```

tvj = transmit video jitter (H.323 calls only) tmlpr = transmit MLP rate (H.320 calls only)
 rvj = receive video jitter (H.323 calls only)
 rmlpr = receive MLP rate (H.320 calls only)
 dc = encryption information
 rsid = remote system id
 ccaps = content capability, where possible responses include "E" (enterprise dual stream)
 tcr = transmit content rate
 rcr = receive content rate
 tcru = transmit content rate used
 rcru = receive content rate used
 tcfr = transmit content frame rate
 rcfr = receive content frame rate
 tcpl = transmit content packet loss
 rcpl = receive content packet loss

Limitations

None

Comments

None

See also

To return network statistics for a call, use the [nearloop](#) command.

dynamicbandwidth

Gets or sets the use of dynamic bandwidth allocation for Quality of Service.

Syntax

dynamicbandwidth <get|yes|no>

Table 1.

Parameter	Description
get	Returns the current setting.
yes	Enables the dynamic bandwidth option.
no	Disables the dynamic bandwidth option.

Feedback Examples

- `dynamicbandwidth yes`
returns
`dynamicbandwidth yes`
- `dynamicbandwidth no`
returns
`dynamicbandwidth no`
- `dynamicbandwidth get`
returns
`dynamicbandwidth no`

Limitations

None

Comments

The system's dynamic bandwidth function automatically finds the optimum speed for a call. If you experience excessive packet loss during a call, the dynamic bandwidth function decrements the speed until there's no packet loss. This is supported in calls with endpoints that also support dynamic bandwidth.

e164ext

Gets or sets an H.323 (IP) extension (also known as an E.164 name).

Syntax

```
e164ext get
e164ext set "e.164name"
```

Table 1.

Parameter	Description
get	Returns the current setting.
set	Sets the E.164 extension when followed by the "e.164name" parameter. To erase the current setting, omit "e.164name".
"e.164name"	A valid E.164 extension (usually a four-digit number).

Feedback Examples

- `e164ext set 7878`
returns
`e164ext 7878`
- returns
- `e164ext get`
returns
`e164ext 7878`

Limitations

None

Comments

The extension number is associated with a specific LAN device.

daylightsavings

Gets or sets the daylight saving time setting. When you enable this setting, the system clock automatically changes for daylight saving time.

Syntax

`daylightsavings <get|yes|no>`

Table 1.

Parameter	Description
get	Returns the current setting.
yes	Enables automatic adjustment for daylight savings time.
no	Disables automatic adjustment for daylight savings time.

Feedback Examples

- `daylightsavings no`

```

returns
daylightsavings no

```

- ```

daylightsavings yes
returns
daylightsavings yes

```
- ```

daylightsavings get
returns
daylightsavings get

```

Limitations

None

Comments

None

enablepvec

Gets or sets the Polycom Video Error Concealment (PVEC) setting on the system.

Syntax

```
enablepvec <get|yes|no>
```

Table 1.

Parameter	Description
get	Returns the current setting.
yes	Enables the PVEC option.
no	Disables the PVEC option.

Feedback Examples

- ```

enablepvec yes
returns
enablepvec yes

```
- ```

enablepvec no

```

```

returns
enablepvec no

```

- ```

enablepvec get
returns
enablepvec no

```

#### Limitations

None

#### Comments

This option, **Enable Lost Packet Recovery** in the web interface, is enabled by default.

### ***enablesipka***

Gets or sets the option to send SIP keep-alive messages.

#### Syntax

```
enablesipka <get|on|off>
```

Table 1.

| Parameter | Description                       |
|-----------|-----------------------------------|
| get       | Returns the current setting.      |
| on        | Enables SIP keep alive messages.  |
| no        | Disables SIP keep alive messages. |

#### Feedback Examples

- ```

enablesipka get
returns
enablepvec no

```
- ```

enablesipka on
returns
enablesipka on

```



Limitations

None

Comments

None

## ***enablesnmp***

Gets or enables/disables SNMP.

Syntax

```
enablesnmp <get | yes | no>
```

Table 1.

| Parameter | Description                  |
|-----------|------------------------------|
| get       | Returns the current setting. |
| yes       | Enables SNMP.                |
| no        | Disables SNMP.               |

Feedback Examples

- `enablesnmp yes`  
returns  
`enablesnmp yes`
- `enablesnmp no`  
returns  
`enablesnmp no`
- `enablesnmp get`  
returns  
`enablesnmp no`

Limitations

None

Comments

None

## **gatekeeperip**

Gets or sets the IP address of the H.323 gatekeeper.

Syntax

```
gatekeeperip get
gatekeeperip set ["xxx.xxx.xxx.xxx"]
```

Table 1.

| Parameter         | Description                                                                                                                            |
|-------------------|----------------------------------------------------------------------------------------------------------------------------------------|
| get               | Returns the current setting.                                                                                                           |
| set               | Sets the gatekeeper IP address when followed by the "xxx.xxx.xxx.xxx" parameter. To erase the current setting, omit "xxx.xxx.xxx.xxx". |
| "xxx.xxx.xxx.xxx" | IP address of the gatekeeper.                                                                                                          |

Feedback Examples

- gatekeeperip set 192.168.1.205  
returns  
gatekeeperip 192.168.1.205
- gatekeeperip get  
returns  
gatekeeperip 192.168.1.205

Limitations

None

Comments

The gatekeeperip get command feedback may include the port number after the IP address.

## **h323authenticateenable**

Enables or disables H.323 authentication.

Syntax

```
h323authenticate enable <get|true|false>
```

Table 1.

| Parameter | Description                    |
|-----------|--------------------------------|
| get       | Returns the current setting.   |
| true      | Enables H.323 authentication.  |
| false     | Disables H.323 authentication. |

#### Feedback Examples

- ```
h323authenticate enable get
```

```
returns
```

```
h323authenticate enable true
```
- ```
h323authenticate enable true
```

```
returns
```

```
h323authenticate enable true
```
- ```
h323authenticate enable false
```

```
returns
```

```
h323authenticate enable false
```

Limitations

None

Comments

None

h323authenticatename

Sets the H.323 name to use to identify the system.

Syntax

```
h323authenticate name get
h323authenticate name "name"
```

Table 1.

Parameter	Description
get	Returns the current H.323 name.
True	The H.323 name to use to identify the system.

Feedback Examples

- `h323authenticate name get`
returns
`h323authenticate name Administrator`
- `h323authenticate name Administrator`
returns
`h323authenticate name Administrator`

Limitations

None

Comments

None

h323authenticatepassword

Sets the password for H.323 authentication.

Syntax

```
h323authenticate password set "password"
```

Table 1.

Parameter	Description
"password"	Password for H.323 authentication.

Feedback Examples

- `h323authenticate password set Polycom`
returns
`h323authenticate password accepted`

Limitations

None

Comments

None

h323name

Gets or sets the system's H.323 name.

Syntax

```
h323name get
h323name set ["H.323name"]
```

Table 1.

Parameter	Description
get	Returns the current setting.
set	Sets the H.323 name when followed by the "H.323name" parameter. To erase this setting, omit the "H.323name" parameter.
"H.323name"	Character string specifying the H.323 name. Use quotation marks around strings that contain spaces. For example: "Demo"

Feedback Examples

- `h323name set My`
returns
`h323name my`
- `h323name set "Demo"`
returns

```
h323name "Demo"
```

- ```
h323name get
```

```
returns
```

```
h323name "Demo"
```

Limitations

None

Comments

None

## ***getconfiguredipaddress***

Retrieves the currently configured IPv4 address from the system.

Syntax

```
getconfiguredipaddress
```

Additional Restrictions

None

Feedback Examples

- ```
getconfiguredipaddress
```



```
returns
```



```
getconfiguredipaddress 1.2.3.4
```

Limitations

None

Comments

`getconfiguredipaddress` returns the system's configured IPv4 address regardless of the status of the LAN connection. This differs from the `ipaddress get` command, which returns the system's IP address if it has an active LAN connection (if not, 0.0.0.0 returns).

The definition of "configured IPv4 address" depends on how the IPv4 address is configured:

- If the IP address is set manually, the configured IP address is returned regardless if the LAN connection is active.
- If the IP address is obtained automatically, the currently-assigned address is returned. 0.0.0.0 returns if there is no active connection.

hostname

Gets or sets the LAN host name, which is assigned to the system for TCP/IP configuration and can be used in place of an IP address when dialing IP calls.

Syntax

```
hostname get  
hostname set ["hostname"]
```

Table 1.

Parameter	Description
get	Returns the current setting.
set	Sets the system's LAN host name when followed by the "hostname" parameter.
"hostname"	<p>Character string specifying the LAN host name of the system. The LAN host name follows these format rules:</p> <p>Starts with a letter (A-a to Z-z). It is not case sensitive. Ends with a letter (A-a to Z-z) or a number (0 to 9).</p> <p>May include letters, numbers, and a hyphen. May not be longer than 36 characters.</p> <hr/> <p>Note The LAN host name is initialized during the setup wizard sequence. The LAN host name is the same as the system name, if the system name conforms to the rules above. If the system name does not conform to these rules, the invalid characters are removed from the system name.</p> <hr/>

Feedback Examples

- hostname set
returns
hostname ADMIN
- hostname set "My"

```
returns
hostname My
```

- `hostname get`
returns
hostname My

Limitations

None

Comments

ALAN host name is required; it cannot be deleted or left blank.

After making a change, you must restart the system for the setting to take effect.

ipaddress

Gets or sets the LAN IP address (IPv4) of the system.

Syntax

```
ipaddress get
ipaddress set "xxx.xxx.xxx.xxx"
```

Table 1.

Parameter	Description
get	Returns the current setting.
set	Sets the LAN IP address to the "xxx.xxx.xxx.xxx" parameter. This setting can only be changed when DHCP is off.
"xxx.xxx.xxx.xxx"	IP address of the system.

Feedback Examples

- `ipaddress set 192.168.1.101`
returns
`ipaddress 192.168.1.101`
- `ipaddress get`

returns

```
ipaddress 192.168.1.101
```

Limitations

None

Comments

Use this command when you need to assign a static IP address to your system. You must restart the system for the setting to take effect.

lanport

Gets or sets the LAN port settings of the system.

Syntax

```
lanport <get|auto|10hdx|10fdx|100hdx|100fdx|1000hdx|1000fdx>
```

Table 1.

Parameter	Description
get	Returns the current setting.
auto 10hdx 10fdx 100hdx 100fdx 1000hdx 1000fdx	Sets the LAN speed and duplex mode. This parameter is not allowed while in a call. auto:Automatically negotiates the LAN speed and duplex mode. 10hdx: 10 Mbps, half duplex 10fdx: 10 Mbps, full duplex 100hdx: 100 Mbps, half duplex 100fdx: 100 Mbps, full duplex 1000hdx:1000 Mbps, half duplex 1000fdx: 1000 Mbps, full duplex

Feedback Examples

- lanport auto

returns

returns

```
lanport auto
restart system for changes to take effect. restart now? <y,n>
```

- lanport get

returns

```
lanport auto
```

Limitations

None

Comments

After making a change, you are prompted to restart the system.

ldapauthenticationtype

Gets or sets the authentication type required to authenticate with an LDAP server.

Syntax

```
ldapauthenticationtype get
ldapauthenticationtype set <anonymous|basic>
```

Table 1.

Parameter	Description
get	Returns the current setting.
set	Sets the authentication type of an LDAP server. <hr/> Note This parameter does not change the setting on the server. Instead, this parameter changes how the Poly system recognizes the server. <hr/>
anonymous	Specifies “anonymous” as the authentication type of an LDAP server.

Parameter	Description
basic	Specifies “basic” as the authentication type of an LDAP server.
ntlm	Specifies “ntlm” as the authentication type of an LDAP server. This is the default setting.

Feedback Examples

- ldapauthenticationtype get
returns
ldapauthenticationtype anonymous
- ldapauthenticationtype set basic
returns
ldapauthenticationtype basic
- ldapauthenticationtypeset ntlm
returns
ldapauthenticationtype ntlm

Limitations

None

Comments

None

ldapbasedn

Gets or sets the base distinguished name (DN) of an LDAP server.

Syntax

```
ldapbasedn get
ldapbasedn set ["base dn"]
```

Table 1.

Parameter	Description
get	Returns the current setting.
set	<p>Sets the base DN of an LDAP server. To erase the current setting, omit the “basedn” parameter.</p> <hr/> <p>Note This parameter does not change the setting on the server. Instead, this parameter changes how the Poly system recognizes the server.</p> <hr/>
“basedn”	<p>Specifies the base DN of an LDAP server. Valid characters include:</p> <p>Unicode(ISO-10646) characters, including IA5/ASCII characters and extended characters such as é, Ø, and å.</p> <hr/> <p>Note To avoid LDAP registration issues, make sure the base DN is at least one level deeper than your domain. For example, set ou=users,dc=example,dc=com instead of dc=example,dc=com.</p> <hr/>

Feedback Examples

- ldapbasedn get
returns
ldapbasedn dc=hardware,dc=domain,dc=Polycom,dc=com where: dc=domain component
- ldapbasedn set dc=software,dc=domain,dc=Polycom,dc=com
returns
ldapbasedn dc=software,dc=domain,dc=Polycom,dc=com where: dc=domain component

Limitations

None

Comments

None

ldapbinddn

Gets or sets the bind DN for LDAP Simple Authentication.

Syntax

```
ldapbinddn get  
ldapbinddn set ["bind dn"]
```

Table 1.

Parameter	Description
get	Returns the current setting.
set	Sets the bind DN for LDAP Simple Authentication. To erase the current setting, omit the "bind dn" parameter. <hr/> Note This parameter does not change the setting on the server. Instead, this parameter changes how the Poly system recognizes the server. <hr/>
"binddn"	Specifies the bind DN of an LDAP server. Valid characters include: Unicode(ISO-10646) characters, including IA5/ASCII characters and extended characters such as é, Ø, and å.

Feedback Examples

- ldapbinddn get
returns
ldapbinddn cn=plcm admin1,ou=plcmsupport,ou=plcmhelp,
dc=hardware,dc=domain,dc=polycom,dc=com where:

cn=common name
ou=organizational unit
dc=domain component

- `ldapbinddn set cn=plcm admin2,ou=plcmaccounts,ou=plcmervice,dc=hardware,dc=domain,dc=polycom,dc=com`

returns

`ldapbinddn cn=plcm admin2,ou=plcmaccounts,ou=plcmervice,dc=hardware,dc=domain,dc=polycom,dc=com` where:
cn=common name
ou=organizational unit
dc=domain component

Limitations

None

Comments

None

ldapdirectory

Gets or sets the LDAP directory server setting.

Syntax

`ldapdirectory <get|yes|no>`

Table 1.

Parameter	Description
get	Returns the current setting.
yes	Enables the LDAP directory server.
no	Disables the LDAP directory server. This is the default setting.

Feedback Examples

- `ldapdirectory get`
returns
`ldapdirectory yes`

- `ldapdirectory no`
returns
`ldapdirectory no`

Limitations

None

Comments

Each Poly system supports a single global directory server at any given time. Therefore, enabling the LDAP directory server automatically disables any other global directory server, such as Poly GDS, which is enabled.

If the Poly GDS and another directory server are defined on the system, Poly GDS becomes the default directory server after upgrading the system software.

ldapntlm domain

Gets or sets the domain in which authentication takes place in the LDAP server.

Syntax

```
ldapntlm domain get
ldapntlm domain set ["domain"]
```

Table 1.

Parameter	Description
get	Returns the current setting.
set	<p>Sets the domain in which authentication takes place in the LDAP server. To erase the current setting, omit the "domain" parameter.</p> <hr/> <p>Note This parameter does not change the setting on the server. Instead, this parameter changes how the Poly system recognizes the server.</p> <hr/>

Parameter	Description
"domain"	<p>Specifies the domain in which authentication takes place in the LDAP server. Valid characters include:</p> <p>0 through 9 , a through z , A through Z , hyphen (-), and period (.)</p> <hr/> <p>Note The domain name cannot begin or end with a hyphen or a period.</p> <hr/>

Feedback Examples

- `ldapntlm domain get`
returns
`ldapntlm domain AUSTIN`
- `ldapntlm domain set ANDOVER`
returns
`ldapntlm domain ANDOVER`

Limitations

None

Comments

None

ldappassword

Sets the password for Simple or NT LAN Manager (NTLM) authentication of an LDAP server.

Syntax

```
ldappassword set ["password"]
```

Table 1.

Parameter	Description
set	<p>Sets the password for Simple authentication of an LDAP server. To erase the current setting, omit the "password" parameter.</p> <hr/> <p>Note This parameter does not change the setting on the server. Instead, this parameter changes how the Poly system recognizes the server.</p> <hr/>
ntlm	<p>Specifies setting the password for NTLM authentication of an LDAP server.</p>
basic	<p>Specifies setting the password for Simple authentication of an LDAP server.</p>
"password"	<p>Specifies the password for Simple or NTLM authentication of an LDAP server. Valid characters include:</p> <p>Unicode(ISO-10646) characters, including IA5/ASCII characters and extended characters such as é, Ø, and å.</p> <hr/> <p>Note The server administrator may specify additional restrictions for password creation.</p> <hr/>

Feedback Examples

- `ldappassword set ntlm P!cnp@s5wd`
returns
`ldappassword NTLM P!cnp@s5wd`
- `ldappassword set basic P0!yc0mp@s5`
returns
`ldappassword BASIC P0!yc0mp@s5`

Limitations

None

Comments

None

ldapserveraddress

Gets or sets the LDAP server address.

Syntax

```
ldapserveraddress get  
ldapserveraddress set ["address"]
```

Table 1.

Parameter	Description
get	Returns the current setting.
set	<p>Sets the IP address or the DNS name of an LDAP server. To erase the current setting, omit the "address" parameter.</p> <hr/> <p>Note This parameter does not change the setting on the server. Instead, this parameter changes how the Poly system recognizes the server.</p> <hr/>

Parameter	Description
"address"	<p>Specifies the IP address or the DNS name of an LDAP server.</p> <p>The DNS name requires alphanumeric characters. Valid characters include:</p> <p>0 through 9</p> <p>a through z</p> <p>A through Z</p> <p>-</p> <hr/> <p>Note The "-" character cannot be used as the first or last character in the DNS name.</p> <hr/>

Feedback Examples

- ```
ldapsveraddress get
returns
ldapsveraddress hardware.domain.polycom.com
```
- ```
ldapsveraddress set software.domain.polycom.com
returns
ldapsveraddress software.domain.polycom.com
```

Limitations

None

Comments

None

ldapsverport

Gets or sets the port number of an LDAP server.

Syntax

```
ldapsverport get
ldapsverport set ["port number"]
```

Table 1.

Parameter	Description
get	Returns the current setting.
set	<p>Sets the port number of an LDAP server. To erase the current setting, omit the “port number” parameter.</p> <hr/> <p>Note This parameter does not change the setting on the server. Instead, this parameter changes how the Poly system recognizes the server.</p> <hr/>
“portnumber”	Specifies the port number of an LDAP server. The default setting is 389.

Feedback Examples

- `ldapserversport get`
returns
`ldapserversport 389`
- `ldapserversport set 636`
returns
`ldapserversport 636`

Limitations

None

Comments

None

ldapslenabled

Gets or sets the Transport Layer Security (TLS) encryption state for LDAP operations.

Syntax

```
ldapsslenabled get
ldapsslenabled set [on|off]
```

Table 1.

Parameter	Description
get	Returns the current setting.
set	Sets the TLS encryption state for LDAP operations. <hr/> Note This parameter does not change the setting on the server. Instead, this parameter changes how the Poly system recognizes the server. <hr/>
on	Specifies “on” as the encryption state for LDAP operations. This is the default setting.
off	Specifies “off” as the encryption state for LDAP operations.

Feedback Examples

- ldapsslenabled get
returns
ldapsslenabled off
- ldapsslenabled set on
returns
ldapsslenabled on

Limitations

None

Comments

None

ldapusername

Gets or sets the user name for NTLM authentication of an LDAP server.

Syntax

```
ldapusername get  
ldapusername set ["user name"]
```

Table 1.

Parameter	Description
get	Returns the current setting.
set	Sets the user name for NTLM authentication of an LDAP server. To erase the current setting, omit the "user name" parameter. <hr/> Note This parameter does not change the setting on the server. Instead, this parameter changes how the Poly system recognizes the server. <hr/>
"username"	Specifies the user name for NTLM authentication of an LDAP server. Valid characters include: Unicode(ISO-10646) characters, including IA5/ASCII characters and extended characters such as é, Ø, and å.

Feedback Examples

- ldapusername get
returns
ldapusername jpolycom
- ldapusername set mpolycom
returns
ldapusername mpolycom

Limitations

None

Comments

None

natconfig

Gets or sets the NAT configuration.

Syntax

```
natconfig <get|auto|manual|off>
```

Table 1.

Parameter	Description
get	Returns the current setting.
auto	Specifies that the system is behind a NAT and that the system will automatically discover the public (WAN) address.
manual	Specifies that the system is behind a NAT. Requires you to assign the WAN address using the wanipaddresscommand.
off	Disables the option when the system is not behind a NAT.

Feedback Examples

- natconfig auto
returns
natconfig auto
- natconfig manual
returns
natconfig manual
- natconfig off
returns
natconfig off

- `natconfig get`
returns
`natconfig off`

Limitations

None

Comments

None

nearloop

Activates or deactivates the Near End Loop test.

Syntax

`nearloop <on|off>`

Table 1.

Parameter	Description
on	Activates the Near End Loop, a complete internal test of the system.
off	Deactivates the Near End Loop.

Feedback Examples

- `nearloop on`
returns
`nearloop on`
- `nearloop off`
returns
`nearloop off`

Limitations

None

Comments

When Near End Loop is on, you can test the encoder/decoder on the system. This test is not available when you are in a call.

netstats

Returns network statistics for each call connection.

Syntax

```
netstats [{0..n}]
```

Table 1.

Parameter	Description
{0..n}	Call in a multipoint call, where n is the maximum number of calls supported by the system. 0 is the first site connected. If no call is specified, netstats returns information about the near site.

Feedback Examples

- netstats 0

returns

```
call:0 txrate:128 K rxrate:128 K pktloss:0 %pktloss:0.0% tvp:H.263 rvp:H.263 tvf:
1 tcp:H.323 rcp:H.323 tcp:- rcp:-- tcf:-- rcf:H.239
```

where:

txrate = transmit clock rate

rxrate = receive clock rate

pktloss = number of packet loss/errors

%pktloss = percentage of packet loss/errors

tvp = transmit video protocol

rvp = receive video protocol

tvf = transmit video format

rvf = receive video format

tap = transmit audio protocol

rap = receive audio protocol tcp = transmit comm protocol

rcp = receive comm protocol

tcp = transmit content protocol

rcp = receive content protocol

tcf = transmit content format

rcf = receive content format

Limitations

None

Comments

Both `pktloss` and `%pktloss` report only numbers related to packet loss on the transmit. These numbers are not affected by packet loss on the Real-time Transport Protocol (RTP) that is received.

The number listed for `%pktloss` is not cumulative and is calculated every five seconds. The number listed for `pktloss` is calculated every 5 seconds and is cumulative.

nath323compatible

Gets or sets whether the NAT is H.323 compatible.

Syntax

```
nath323compatible <get|yes|no>
```

Table 1.

Parameter	Description
get	Returns the current setting.
yes	Specifies that NAT is capable of translating H.323 traffic.
no	Specifies that NAT is not capable of translating H.323 traffic.

Feedback Examples

- `nath323compatible yes`
returns
`nath323compatible yes`
- `nath323compatible no`
returns
`nath323compatible no`
- `nath323compatible get`
returns
`nath323compatible no`

Limitations

None

Comments

None

ntpmode

Sets the Network Time Protocol (NTP) server mode, which determines how the system connects to the time server to obtain time settings.

Syntax

```
ntpmode <get|auto|off|manual>
```

Table 1.

Parameter	Description
get	Returns the current time server mode.
auto	Sets the connection to the time server as automatic.
off	Turns off the connection to the time server.
manual	Sets the connection to the time server as manual. You can then use the <code>ntpserver</code> command to manually set the NTP server address.

Feedback Examples

- `ntpmode get`
returns
`ntpmode manual`
- `ntpmode auto`
returns
`ntpmode auto`
- `ntpmode off`
returns
`ntpmode off`

- `ntpmode manual`
returns
`ntpmode manual`

Limitations

None

Comments

None

ntpsecondaryserver

Sets the NTP server to use for time settings when the primary time server does not respond.

Syntax

```
ntpsecondaryserver get
ntpsecondaryserver set <"xxx.xxx.xxx.xxx" | server name">
```

Table 1.

Parameter	Description
get	Returns the current setting.
set	Sets the IP address of the NTP server using the specified IP address or DNS name.

Feedback Examples

- `ntpsecondaryserver get`
returns
`ntpsecondaryserver 172.26.44.22`
- `ntpsecondaryserver set`
returns
`ntpsecondaryserver ""`
- `ntpsecondaryserver set 172.26.44.22`
returns
`ntpsecondaryserver 172.26.44.22`

Limitations

None

Comments

You must first set the `ntpmode` command to `manual` before using the `ntpsecondaryserver` command.

ntpserver

Sets the NTP server to use for time settings when the time server is set to `manual`.

Syntax

```
ntpserver get  
ntpserver set <"xxx.xxx.xxx.xxx"|server name">
```

Table 1.

Parameter	Description
get	Returns the current setting.
set	Sets the IP address of the NTP server using the specified IP address or DNS name.

Feedback Examples

- `ntpserver get`
returns
`ntpserver 192.168.1.205`
- `ntpserver set`
returns
`ntpserver <empty>`
- `ntpserver set 192.168.1.205`
returns
`ntpserver 192.168.1.205`

Limitations

None

Comments

You must first set the ntpmode command to manual before using the ntpserver command.

rs232 baud

Gets or sets the baud rate for the first RS-232 port.

Syntax

```
rs232 baud <get | 9600 | 19200 | 38400 | 57600 | 115200>
```

Table 1.

Parameter	Description
get	Returns the current baud rate setting.
9600 19200 38400 57600 115200	Sets the RS-232 port to this baud rate.

Feedback Examples

- rs232 baud 9600
returns
rs232 baud 9600
- rs232 baud get
returns
rs232 baud 9600

Limitations

None

Comments

None

rs232 mode

Gets or sets the operational mode of the system's serial port.

Syntax

```
rs232 mode <get | off | control>
```

Table 1.

Parameter	Description
get	Returns the current mode setting.
off	Sets the operational mode of the RS-232 port to off.
control	Sets the RS-232 port to Control mode.

Feedback Examples

- `rs232 mode control`
returns
`rs232 mode control`

Limitations

None

Comments

None

rs232login

Gets or sets the serial port login requirements.

Syntax

`rs232login <get|off|pwnonly|pwuser>`

Table 1.

Parameter	Description
get	Returns the current setting.
off	Disables RS232 login requirements.

Parameter	Description
pwnly	Sets the serial port login requirement to use only the admin password.
pwuser	Sets the serial port login requirement to use both admin and user passwords.

Feedback Examples

- `rs232login get`
returns
`rs232login off`
- `rs232login pwnly`
returns
`rs232login pwnly`

Limitations

None

Comments

None

snmpadmin

Gets or sets your SNMP support contact name.

Syntax

```
snmpadmin get
snmpadmin set ["admin name"]
```

Table 1.

Parameter	Description
get	Returns the current setting.
set	Sets the administrator name when followed by the "admin name" parameter. To erase the current setting, omit "admin name".
"admin name"	SNMP administrator contact name. Character string. Enclose the character string in quotation marks if it includes spaces. Example: "John Admin"

Feedback Examples

- `snmpadmin get`
returns
`snmpadmin "John Admin"`
- `snmpadmin set "John Admin"`
returns
`snmpadmin "John Admin"`
- `snmpadmin set`
returns
`error: command needs more parameters to execute successfully`

Limitations

None

Comments

After making a change, you must restart the system for the setting to take effect.

snmpcommunity

Gets or sets the SNMP community string.

Syntax

```
snmpcommunity get
snmpcommunity set ["community name"]
```

Table 1.

Parameter	Description
get	Returns the current setting.
set	Sets the SNMP community name when followed by the "community name" parameter. To erase the current setting, omit the parameter.
"community name"	SNMP community name. Character string. Enclose the character string in quotation marks if it includes spaces.

Feedback Examples

- snmpcommunity set
returns
snmpcommunity <empty>
- snmpcommunity set Public
returns
snmpcommunity Public
- snmpcommunity get
returns
snmpcommunity Public

Limitations

None

Comments

After making a change, you must restart the system for the setting to take effect.

snmpconsoleip

Gets or sets the SNMP console IP address.

Syntax

```
snmpconsoleip get
snmpconsoleip set ["xxx.xxx.xxx.xxx"]
```

Table 1.

Parameter	Description
get	Returns the current setting.
set	Sets the SNMP console application IP address when followed by the xxx.xxx.xxx.xxx" parameter. To erase the current setting, omit the parameter.
"xxx.xxx.xxx.xxx"	IP address of the console.

Feedback Examples

- `snmpconsoleip set`
returns
`snmpconsoleip <empty>`
- `snmpconsoleip set 192.168.1.111`
returns
`snmpconsoleip 192.168.1.111`
- `snmpconsoleip get`
returns
`snmpconsoleip 192.168.1.111`

Limitations

None

Comments

After making a change, you must restart the system for the setting to take effect.

snmplocation

Gets or sets the location of the SNMP system.

Syntax

```
snmplocation get  
snmplocation ["location name"]
```

Table 1.

Parameter	Description
get	Returns the current setting.
"location name"	SNMP system location. Enclose the location name in quotation marks if it includes spaces. To erase the current setting, omit the parameter.

Feedback Examples

- snmplocation
returns
snmplocation <empty>
- snmplocation set "Polycom1 in United States"
returns
snmplocation "Polycom1 in United States"
- snmplocation get
returns
snmplocation "Polycom1 in United States"

Limitations

None

Comments

You must restart the system after making a change to the SNMP setting.

snmpnotification

Enables or disables SNMP notifications for the Poly MIB, which can be downloaded from the SNMP page in the system web interface.

Syntax

snmpnotification <get|true|false>

Table 1.

Parameter	Description
get	Returns the current setting for SNMP notifications.
true	Enables SNMP notifications.
false	Disables SNMP notifications.

Feedback Examples

- snmpnotification get
returns
snmpnotification true
- snmpnotification true
returns
snmpnotification true
- snmpnotification false
returns
snmpnotification false

Limitations

None

Comments

None

snmpsystemdescription

Gets or sets the SNMP system description.

Syntax

```
snmpsystemdescription get  
snmpsystemdescription set ["system description"]
```

Table 1.

Parameter	Description
get	Returns the current setting.
set	Sets the SNMP system description when followed by the “system description” parameter. To erase the current setting, omit the parameter.
“system description”	SNMP system description.

Feedback Examples

- `snmpsystemdescription set`
returns
`snmpsystemdescription <empty>`
- `snmpsystemdescription set “videoconferencing system”`
returns
`snmpsystemdescription “videoconferencing system”`
- `snmpsystemdescription get`
returns
`snmpsystemdescription “videoconferencing system”`

Limitations

None

Comments

After making a change, you must restart the system for the setting to take effect.

snmptrapversion

Gets or sets the SNMP trap version.

Syntax

```
snmptrapversion get
snmptrapversion set <v1|v2c|v3>
```

Table 1.

Parameter	Description
get	Returns the current setting.
set	Sets the SNMP trap protocol that the system uses.
v1 v2c v3	SNMP trap version 1, 2c, or 3.

Feedback Examples

- `snmptrapversion get`
returns
`snmptrapversion v2c`
- `snmptrapversion set v3`
returns
`snmptrapversion v3`

Limitations

None

Comments

After making a change, you must restart the system for the setting to take effect.

subnetmask

Gets or sets the subnet mask of the system.

Syntax

```
subnetmask get
subnetmask set ["xxx.xxx.xxx.xxx"]
```

Table 1.

Parameter	Description
get	Returns the current subnet mask.
set	Sets the subnet mask of the system when followed by the "xxx.xxx.xxx.xxx" parameter. To erase the current setting, omit "xxx.xxx.xxx.xxx". This parameter is not allowed while in a call.
"xxx.xxx.xxx.xxx"	Subnet mask of the system.

Feedback Examples

- `subnetmask set 255.255.255.0`
returns
`subnetmask 255.255.255.0`
- `subnetmask get`
returns
`subnetmask 255.255.255.0`

Limitations

None

Comments

After making a change, you must restart the system for the setting to take effect.

usegatekeeper

Gets or sets whether the system can use an H.323 gatekeeper.

Syntax

`usegatekeeper <get|off|specify|auto>`

Table 1.

Parameter	Description
get	Returns the current setting.
off	Select this option if no gatekeeper is required.
specify	Specifies a gatekeeper. If this option is selected, you must enter the gatekeeper IP address or name using <code>gatekeeperip</code> .
auto	Sets the system to automatically find an available gatekeeper.

Feedback Examples

- `usegatekeeper off`
returns
`usegatekeeper off`
- `usegatekeeper specify`
returns
`usegatekeeper specify`
- `usegatekeeper auto`
returns
`usegatekeeper auto`
- `usegatekeeper get`
returns
`usegatekeeper auto`

Limitations

None

Comments

None

wanipaddress

Gets or sets the WAN IP address.

Syntax

```
wanipaddress get  
wanipaddress set ["xxx.xxx.xxx.xxx"]
```

Table 1.

Parameter	Description
get	Returns the WAN IP address.
set	Sets the WAN IP address when followed by the "xxx.xxx.xxx.xxx" parameter. To erase the current setting, omit the "xxx.xxx.xxx.xxx" parameter.
"xxx.xxx.xxx.xxx"	WAN IP address.

Feedback Examples

- ```
wanipaddress set 192.168.1.101
```

```
returns
```

```
wanipaddress 192.168.1.101
```
- ```
wanipaddress get
```

```
returns
```

```
wanipaddress 192.168.1.101
```

Limitations

None

Comments

The **NAT Configuration** setting must be set to **Auto** or **Manual** to set this command.

Provisioning APIs

- [provisionserveraddress](#)

- Gets or sets the IP address for the provisioning server.
- [provisionserverdomain](#)
Gets or sets the domain name of the provisioning server.
- [provisionserverenable](#)
Gets or sets the current setting for the provisioning server.
- [provisionserverpassword](#)
Sets the password for the provisioning server.
- [provisionserverupdate](#)
Updates the connection to the provisioning server.
- [provisionserverstatus](#)
Gets the current status of the provisioning server.
- [provisionservertype](#)
Gets or sets the provisioning server type.
- [provisionserverupdate](#)
Updates the connection to the provisioning server.
- [provisionserveruser](#)
Gets or sets the username assigned to the provisioning server account.

provisionserveraddress

Gets or sets the IP address for the provisioning server.

Syntax

```
provisionserveraddress <get|set> <"Server Address">
```

Table 1.

Parameter	Description
get	Returns the current setting.
set	Sets the IP address of the provisioning server.
"Server Address"	Specifies the IP address to use when using the set command.

Feedback Examples

- `provisionserveraddress get`
returns
`provisionserveraddress 10.223.15.152`
- `provisionserveraddress set 192.168.1.1`
returns
`provisionserveraddress 192.168.1.1`

Limitations

None

Comments

None

provisionserverdomain

Gets or sets the domain name of the provisioning server.

Syntax

`provisionserverdomain <get|set|"domain name">`

Table 1.

Parameter	Description
get	Returns the current setting.
set	Sets the domain name of the provisioning server.
"Server Address"	Specifies the domain name for the provisioning server address when using the <code>set</code> command.

Feedback Examples

- `provisionserverdomain get`
returns
`provisionserverdomain Polycom`
- `provisionserverdomain set corporate1`

```
returns
provisionserverdomain corporate1
```

Limitations

None

Comments

None

provisionserverenable

Gets or sets the current setting for the provisioning server.

Syntax

```
provisionserverenable <get|true|false>
```

Table 1.

Parameter	Description
get	Returns the current setting.
true	Enables the provisioning server.
false	Disables the provisioning server.

Feedback Examples

- ```
provisionserverenable get
returns
provisionserverenable false
```
- ```
provisionserverenable true
returns
provisionserverenable true
```
- ```
provisionserverenable false
returns
provisionserverenable false
```

Limitations

None

Comments

None

## ***provisionserverpassword***

Sets the password for the provisioning server.

Syntax

```
provisionserverpassword set <"password">
```

Table 1.

| Parameter  | Description                                                                    |
|------------|--------------------------------------------------------------------------------|
| set        | Sets the password for the provisioning server.                                 |
| "password" | Specifies the password for the provisioning server when using the set command. |

Feedback Examples

- `provisionserverpassword set "Polycom01"`  
returns  
`provisionserverpassword accepted`
- `provisionserverpassword set Pcom 01`  
returns  
`error: command has illegal parameters.`
- `provisionserverpassword set "Pcom 01"`  
returns  
`provisionserverpassword accepted`

Limitations

None

Comments

None

## ***provisionserverupdate***

Updates the connection to the provisioning server.

Syntax

```
provisionserverupdate
```

Additional Restrictions

None

Feedback Examples

- `provisionserverupdate`  
returns  
`provisionserverupdate success`
- `provisionserverupdate`  
returns  
`provisionserverupdate failed`
- `provisionserverupdate`  
returns  
`provisioning is already in progress`

Limitations

None

Comments

None

## ***provisionserverstatus***

Gets the current status of the provisioning server.

Syntax

```
provisionserverstatus <get>
```

Table 1.

| Parameter | Description                                            |
|-----------|--------------------------------------------------------|
| get       | Returns the current status of the provisioning server. |

#### Feedback Examples

- ```
provisionserverstatus get
returns
provisionserverstatus registered
```
- ```
provisionserverstatus get
returns
provisionserverstatus unregistered
```

#### Limitations

None

#### Comments

None

## ***provisionservertype***

Gets or sets the provisioning server type.

#### Syntax

```
provisionservertype <get|rpm>
```

Table 1.

| Parameter | Description                                                         |
|-----------|---------------------------------------------------------------------|
| get       | Returns the current setting.                                        |
| rpm       | Sets the provisioning server type to RealPresence Resource Manager. |

#### Feedback Examples



- `provisionservertype get`  
returns  
`provisionservertype rpm`
- `provisionservertype rpm`  
returns  
`provisionservertype rpm`

#### Limitations

None

#### Comments

None

## ***provisionserverupdate***

Updates the connection to the provisioning server.

#### Syntax

```
provisionserverupdate
```

#### Additional Restrictions

None

#### Feedback Examples

- `provisionserverupdate`  
returns  
`provisionserverupdate success`
- `provisionserverupdate`  
returns  
`provisionserverupdate failed`
- `provisionserverupdate`  
returns  
`provisioning is already in progress`

#### Limitations

None

#### Comments

None

## ***provisionserveruser***

Gets or sets the username assigned to the provisioning server account.

Syntax

```
provisionserveruser <get|set> <"Username">
```

Table 1.

| Parameter  | Description                                                                    |
|------------|--------------------------------------------------------------------------------|
| get        | Returns the current setting.                                                   |
| set        | Sets the username for the provisioning server.                                 |
| "UserName" | Specifies the username for the provisioning server when using the set command. |

Feedback Examples

- `provisionserveruser get`  
returns  
`provisionserveruser "John Smith"`
- `provisionserveruser set "Harry Thomas"`  
returns  
`provisionserveruser "Harry Thomas"`

Limitations

None

Comments

None

## ***Security APIs***

- [setpassword](#)  
Sets the system's local administrator account password.

- [sshenable](#)  
Enables command-line API access over SSH.
- [encryption](#)  
Gets or sets the AES encryption mode for the system.

## ***setpassword***

Sets the system's local administrator account password.

Syntax

```
setpassword admin room "currentacctpasswd" "newacctpasswd"
```

Table 1.

| Parameter           | Description                                         |
|---------------------|-----------------------------------------------------|
| admin               | Specifies the system's local administrator account. |
| room                | Needed to change the password.                      |
| "currentacctpasswd" | The current password.                               |
| "newacctpasswd"     | The new password.                                   |

Feedback Examples

- `setpassword admin room 123 456`  
returns  
password changed
- `setpassword admin room ' ' 456`  
returns  
password changed
- `setpassword admin room 123 ' '`  
returns  
password changed

Limitations

None

Comments

If the account doesn't have password, enter a pair of single quotes (") to denote an empty password.

## **sshenable**

Enables command-line API access over SSH.

Syntax

```
sshenable <true|false>
```

Table 1.

| Parameter | Description                               |
|-----------|-------------------------------------------|
| true      | Enables command-line API access over SSH. |
| false     | Disables command-line API access over SSH |

Feedback Examples

- sshenable true  
returns  
sshenable true
- sshenable false  
returns  
sshenable false

Limitations

None

Comments

None

## **Security APIs**

- [setpassword](#)  
Sets the system's local administrator account password.

- [sshenable](#)  
Enables command-line API access over SSH.
- [encryption](#)  
Gets or sets the AES encryption mode for the system.

## **encryption**

Gets or sets the AES encryption mode for the system.

Syntax

```
encryption <get|yes|no|requiredvideocallonly|requiredallcalls>
```

Table 1.

| Parameter             | Description                                                                                                                                                           |
|-----------------------|-----------------------------------------------------------------------------------------------------------------------------------------------------------------------|
| get                   | Returns the current setting.                                                                                                                                          |
| yes                   | Use encryption when the far site is capable of encryption.<br><hr/> <b>Note</b> This parameter is <b>When Available</b> in the user interface. <hr/>                  |
| no                    | Disables encryption.<br><hr/> <b>Note</b> This parameter is <b>Off</b> in the web interface. <hr/>                                                                    |
| requiredvideocallonly | Enforces encryption on all video endpoints. Any video calls to or from systems that do not have encryption enabled are not connected. Audio-only calls are connected. |
| requiredallcalls      | Enforces encryption on all endpoints. Any video or audio calls to or from systems that do not have encryption enabled are rejected and are not connected.             |

Feedback Examples

- `encryption yes`  
returns  
`encryption yes`
- `encryption no`  
returns  
`encryption no`
- `encryption get`  
returns  
`encryption no`
- `encryption requiredvideocallsonly`  
returns  
`encryption requiredvideocallsonly`
- `encryption requiredallcalls`  
returns  
`encryption requiredallcalls`

#### Limitations

None

#### Comments

You cannot execute the encryption command while a call is in progress. Using this command while the system is in a call returns the following message:

```
error:command has illegal parameters
```

## ***System control and remote control APIs***

- [button](#)  
Simulates remote control buttons. Some commands may not be available with your conferencing provider.
- [all register](#)  
Registers for most commonly-used user registration events.
- [all unregister](#)  
Simultaneously unregisters all registered user feedback so that the API no longer reports changes to the parameters.

### ***button***

Simulates remote control buttons. Some commands may not be available with your conferencing provider.

### Syntax

Parameters available in Poly Video Mode only:

```
button <call|graphics|hangu_p>
button <camera|directory|home|info|keyboard|mute>
```

Parameters available for all conferencing applications:

```
button <#|*|0|1|2|3|4|5|6|7|8|9|. >
button <down|left|right|up|select>
button <back|menu>
button <mute|volume+|volume->
button <delete|period>
```

Table 1.

| Parameter           | Description                                                                                                                                                                            |
|---------------------|----------------------------------------------------------------------------------------------------------------------------------------------------------------------------------------|
| .                   | Types a period if the cursor is on a text field.                                                                                                                                       |
| #                   | Sends the #button signal to the user interface.                                                                                                                                        |
| *                   | Sends the *button signal to the user interface.                                                                                                                                        |
| 0 1 2 3 4 5 6 7 8 9 | Sends the corresponding numeric button signal to the user interface.                                                                                                                   |
| back                | Returns you to the previous screen.                                                                                                                                                    |
| call                | Displays the <b>Call</b> screen.                                                                                                                                                       |
| camera              | Displays the <b>Camera Control</b> screen. If camera tracking is enabled the <b>Camera Control</b> screen doesn't display. You must disable camera tracking before using this command. |
| delete              | Deletes the last character in a text field.                                                                                                                                            |

| Parameter | Description                                                                                                                                                                                             |
|-----------|---------------------------------------------------------------------------------------------------------------------------------------------------------------------------------------------------------|
| directory | Displays the contacts view in the <b>Call screen</b> . If the contacts view isn't configured no action is taken.                                                                                        |
| down      | Sends the <b>Down</b> button signal to the user interface.                                                                                                                                              |
| graphics  | In a content sharing session, displays the content tray.<br><br>Out of a content sharing session, displays the <b>Contents</b> screen.                                                                  |
| hangup    | In a call, removes all content, ends the call, and returns you to the <b>Home</b> screen. In a content session, removes all content, ends the session, and returns you to the <b>Home</b> screen.       |
| home      | Returns you to the <b>Home</b> screen.                                                                                                                                                                  |
| info      | Displays the video system's <b>System Detail</b> screen.                                                                                                                                                |
| keyboard  | Brings up the on-screen keyboard if the cursor is on a text field.                                                                                                                                      |
| left      | Sends the <b>Left</b> button signal to the user interface.                                                                                                                                              |
| menu      | In Poly Video mode, displays the quick access menu.<br><br>In Partner Mode, performs the same action as the remote control <b>Menu</b> button action for the selected conferencing partner application. |



| Parameter | Description                                                                                  |
|-----------|----------------------------------------------------------------------------------------------|
| mute      | Toggles microphone mute.                                                                     |
| period    | Types a period if the cursor is in a text field.                                             |
| right     | Sends the <b>Right</b> button signal to the user interface.                                  |
| select    | Sends the <b>Select</b> (center button in the directional pad) button to the user interface. |
| up        | Sends the <b>Up</b> button to the user interface.                                            |
| volume-   | Decreases the system volume.                                                                 |
| volume+   | Increases the system volume.                                                                 |

#### Feedback examples

- button hangup  
returns  
button hangup
- button up  
sends the up command to the user interface and returns  
button up

The command checks for invalid input and reports the button responses as they're processed. The system returns one of three status values when you issue a command for multiple buttons:

- succeeded - All buttons are valid.
- failed - All input is invalid and none of the commands perform a valid action.

For example:

- button camera right center select

```
returns
button camera
button right
error: button center not a recognized command button select
button completed
```

Long button command sequences complete before the system executes a second command. Feedback for button sequences that include multiple buttons show only the first button name.

#### Limitations

Some button commands require you to return to the **Home** screen before execution. If you don't return to the **Home** screen the command may not execute properly.

#### Comments

You can combine several parameters in the same command in any order.

Use the camera command for camera control. Don't use the following commands for camera control:

- button left
- button right
- button down
- button up

## ***all register***

Registers for most commonly-used user registration events.

#### Syntax

```
allregister
```

#### Additional restrictions

None

#### Feedback examples

```
allregister
```

#### returns

```
callstate registered
camera registered
linestate registered mute registered
preset registered
vbutton registered
volume registered
```

## Comments

Registers changes to any of the following types of parameters:

- Current near- or far-site source
- State of privacy
- Current volume level
- Active camera presets
- Call status
- IP connection to codec
- System information

This command is useful when two control systems are used simultaneously, such as the web and API commands. The system maintains the registration changes through restarts.

To register for events not included in this feedback, refer to the specific registration command.

This is a one-time registration command that is retained in flash memory. Sending the command a second time results in the following feedback response:

```
info: event/notification already active:callstate
info: event/notification already active:camera
info: event/notification already active:linestate
info: event/notification already active:mute
info: event/notification already active:preset
info: event/notification already active:vcbutton
info: event/notification already active:volume
```

The `all register` command does not return local camera movements if the camera is moved using the remote control.

Use the [notify](#) command for camera notifications.

## Limitations

None

## ***all unregister***

Simultaneously unregisters all registered user feedback so that the API no longer reports changes to the parameters.

## **Syntax**

```
allunregister
```

Additional restrictions

None

Feedback examples

```
all unregister
```

returns

```
callstate unregistered
camera unregistered
linestate unregistered
mute unregistered
preset unregistered
vcbUTTON unregistered
volume unregistered
```

Limitations

None

Comments

The following types of parameters are unregistered:

- Current near-site or far-site source
- State of privacy
- Current volume level
- Active camera presets
- Status of point-to-point or multipoint calls
- IP connection to codec
- System information

## ***System settings APIs***

- [systemsetting 323gatewayenable](#)  
Gets the current setting or enables H.323 calling through a gateway
- [systemsetting bfcptransportprotocol](#)  
Gets the current setting or indicates the Binary Floor Control Protocol (BFCP) connection and provides an option to set the connection preference to UDP or TCP.
- [systemsetting dialingmethod](#)  
Gets or sets the preferred method for dialing various call types.
- [systemsetting displayiconsincall](#)  
Gets or specifies whether to display icons on the Home Screen during a call.
- [systemsetting iph323enable](#)

- Gets the current setting or specifies whether H.323 calls are allowed.
- [systemsetting lineinlevel](#)
  - Gets the current setting or returns the volume level for 3.5 mm stereo audio input.
- [systemsetting lineoutmode](#)
  - Gets the current setting or specifies whether the volume for a device connected to the 3.5 mm line stereo audio output port is variable or fixed.
- [systemsetting maxrxbandwidth](#)
  - Gets the sets the maximum receive line speed between 64 kbps and 6144 kbps.
- [systemsetting maxtxbandwidth](#)
  - Gets or sets the maximum transmit line speed between 64 kbps and 6144 kbps.
- [systemsetting mediainlevel](#)
  - Gets or specifies the volume level for the content 3.5 mm stereo audio input.
- [systemsetting model](#)
  - Returns the model of the system.
- [systemsetting sipaccountname](#)
  - Gets or sets the SIP user account name.
- [systemsetting sipdebug](#)
  - Gets or sets the state of SIP debug tracing in the system log.
- [systemsetting sipenable](#)
  - Enables or disables SIP calling.
- [systemsetting sipforcereuse](#)
  - Enables or disables the SIP force reuse function, which forces the proxy server to reuse the existing SIP connection for requests in the reverse direction by using the SIP port as the source port.
- [systemsetting sippassword](#)
  - Sets the SIP server password.
- [systemsetting sipproxyserver](#)
  - Gets or sets the address of the SIP proxy server.
- [systemsetting sipregistrarserver](#)
  - Gets or sets the address of the SIP registrar server.
- [systemsetting siptransportprotocol](#)
  - Gets or sets the protocol the system uses for SIP signaling.
- [systemsetting sipusername](#)
  - Gets or sets the system's SIP name.
- [systemsetting stereoenable](#)
  - Gets the current setting or specifies whether Polycom® StereoSurround™ technology is used for all calls.
- [systemsetting telnetenabled](#)
  - Gets or sets the telnet ports.

- [systemsetting transcodingenabled](#)  
Gets or specifies whether the system allows each far-site system to connect using the best possible call rate and audio/video algorithm.
- [systemsetting webenabled](#)  
Gets or specifies whether to allow remote access to the system using the web interface.
- [systemsetting whitebalancemode](#)  
Gets or sets the white balance mode for a connected Poly camera.

## **systemsetting 323gatewayenable**

Gets the current setting or enables H.323 calling through a gateway

Syntax

```
systemsetting 323gatewayenable <True|False>
systemsetting get 323gatewayenable
```

Table 1.

| Parameter | Description                   |
|-----------|-------------------------------|
| get       | Returns the current setting.  |
| True      | Enables H.323 gateway calls.  |
| False     | Disables H.323 gateway calls. |

Feedback Examples

- `systemsetting 323gatewayenable True`  
returns  
`systemsetting 323gatewayenable True`
- `systemsetting get 323gatewayenable`  
returns  
`systemsetting 323gatewayenable True`

Limitations

None

Comments

None

## ***systemsetting bfcpttransportprotocol***

Gets the current setting or indicates the Binary Floor Control Protocol (BFCP) connection and provides an option to set the connection preference to UDP or TCP.

Syntax

```
systemsetting bfcpttransportprotocol <Prefer_UDP|Prefer_TCP|UDP_Only|TCP_Only>
systemsetting get bfcpttransportprotocol
```

Table 1.

| Parameter  | Description                                      |
|------------|--------------------------------------------------|
| get        | Returns the current setting.                     |
| Prefer_TCP | Specifies TCP as the BFCP connection preference. |
| Prefer_UDP | Specifies UDP as the BFCP connection preference. |
| UDP_Only   | Specifies UDP as the BFCP transport protocol.    |
| TCP_Only   | Specifies TCP as the BFCP transport protocol.    |

### Feedback Examples

- ```
systemsetting get bfcpttransportprotocol  
returns  
systemsetting bfcpttransportprotocol Prefer_UDP
```
- ```
systemsetting bfcpttransportprotocol Prefer_TCP
returns
systemsetting bfcpttransportprotocol Prefer_TCP
```
- ```
systemsetting get bfcpttransportprotocol  
returns
```

```
systemsetting bfcptransportprotocol Prefer_TCP
```

- ```
systemsetting bfcptransportprotocol UDP_Only
```

  
returns  

```
systemsetting bfcptransportprotocol UDP_Only
```

Limitations

None

Comments

None

## ***systemsetting dialingmethod***

Gets or sets the preferred method for dialing various call types.

Syntax

```
systemsetting dialingmethod <Auto|Manual>
systemsetting get dialingmethod
```

Table 1.

| Parameter | Description                                                                                                           |
|-----------|-----------------------------------------------------------------------------------------------------------------------|
| get       | Returns the current setting.                                                                                          |
| Auto      | Sets the dialing mode to Auto. Calls use the configured dialing order.                                                |
| Manual    | Sets the dialing mode to Manual. The system prompts the user to select the call type from a list when placing a call. |

Feedback Examples

- ```
systemsetting dialingmethod Auto
```

returns

```
systemsetting dialingmethod Auto
```
- ```
systemsetting get dialingmethod
```

  
returns



```
systemsetting dialingmethod Auto
```

Limitations

None

Comments

None

## ***systemsetting displayiconsincall***

Gets or specifies whether to display icons on the Home Screen during a call.

Syntax

```
systemsetting displayiconsincall <True|False>
systemsetting get displayiconsincall
```

Table 1.

| Parameter | Description                                                         |
|-----------|---------------------------------------------------------------------|
| get       | Returns the current setting.                                        |
| True      | Specifies to display the icons on the info bar while in a call.     |
| False     | Specifies to not display the icons on the info bar while in a call. |

Feedback Examples

- ```
systemsetting displayiconsincall True
```

returns

```
systemsetting displayiconsincall True
```
- ```
systemsetting get displayiconsincall
```

  
returns  

```
systemsetting displayiconsincall True
```

Limitations

None

Comments

None

## ***systemsetting iph323enable***

Gets the current setting or specifies whether H.323 calls are allowed.

Syntax

```
systemsetting iph323enable <True|False>
systemsetting get iph323enable
```

Table 1.

| Parameter | Description                     |
|-----------|---------------------------------|
| get       | Returns the current setting.    |
| True      | Enables H.323 call capability.  |
| False     | Disables H.323 call capability. |

Feedback Examples

- `systemsetting iph323enable True`  
returns  
`systemsetting iph323enable True`
- `systemsetting get iph323enable`  
returns  
`systemsetting iph323enable True`

Limitations

None

Comments

None

## ***systemsetting lineinlevel***

Gets the current setting or returns the volume level for 3.5 mm stereo audio input.

#### Syntax

```
systemsetting lineinlevel {0..10}
systemsetting get lineinlevel
```

Table 1.

| Parameter | Description                                                |
|-----------|------------------------------------------------------------|
| get       | Returns the current setting.                               |
| 0..10     | Sets the volume level for input 1. Valid range is 0 to 10. |

#### Feedback Examples

- ```
systemsetting lineinlevel 5
```

returns

```
systemsetting lineinlevel 5
```
- ```
systemsetting get lineinlevel
```

  
returns  

```
systemsetting lineinlevel 5
```

#### Limitations

None

#### Comments

None

## ***systemsetting lineoutmode***

Gets the current setting or specifies whether the volume for a device connected to the 3.5 mm line stereo audio output port is variable or fixed.

#### Syntax

```
systemsetting lineoutmode <fixed|variable>
systemsetting get lineoutmode
```

Table 1.

| Parameter | Description                                                    |
|-----------|----------------------------------------------------------------|
| get       | Returns the current setting.                                   |
| fixed     | Sets the volume to the audio level specified in the interface. |
| variable  | Allows users to set the volume with the remote control.        |

#### Feedback Examples

- `systemsetting lineoutmode fixed`  
returns  
`systemsetting lineoutmode fixed`
- `systemsetting get lineoutmode`  
returns  
`systemsetting lineoutmode fixed`

#### Limitations

None

#### Comments

None

### ***systemsetting maxrxbandwidth***

Gets the sets the maximum receive line speed between 64 kbps and 6144 kbps.

#### Syntax

```
systemsetting maxrxbandwidth [speed]
systemsetting get maxrxbandwidth
```

Table 1.

| Parameter | Description                                 |
|-----------|---------------------------------------------|
| get       | Returns the current setting.                |
| speed     | Sets the maximum speed for receiving calls. |

#### Feedback Examples

- `systemsetting maxrxbandwidth 1920`  
returns  
`systemsetting maxrxbandwidth 1920`
- `systemsetting get maxrxbandwidth`  
returns  
`systemsetting maxrxbandwidth 1920`

#### Limitations

None

#### Comments

None

### ***systemsetting maxtxbandwidth***

Gets or sets the maximum transmit line speed between 64 kbps and 6144 kbps.

#### Syntax

```
systemsetting maxtxbandwidth [speed]
systemsetting get maxtxbandwidth
```

Table 1.

| Parameter | Description                               |
|-----------|-------------------------------------------|
| get       | Returns the current setting.              |
| speed     | Sets the maximum speed for placing calls. |

#### Feedback Examples

- `systemsetting maxtxbandwidth 1920`  
returns  
`systemsetting maxtxbandwidth 1920`
- `systemsetting get maxtxbandwidth`  
returns  
`systemsetting maxtxbandwidth 1920`

#### Limitations

None

#### Comments

None

### ***systemsetting mediainlevel***

Gets or specifies the volume level for the content 3.5 mm stereo audio input.

#### Syntax

```
systemsetting mediainlevel <0..10>
systemsetting get mediainlevel
```

Table 1.

| Parameter | Description                                                      |
|-----------|------------------------------------------------------------------|
| get       | Returns the current setting.                                     |
| 0..10     | Sets the volume level of the media input to the specified value. |

#### Feedback Examples

- `systemsetting mediainlevel 5`  
returns  
`systemsetting mediainlevel 5`
- `systemsetting get mediainlevel`  
returns  
`systemsetting mediainlevel 5`

#### Limitations

None

#### Comments

None

### ***systemsetting model***

Returns the model of the system.

#### Syntax

`systemsetting get model`

Table 1.

| Parameter | Description                  |
|-----------|------------------------------|
| get       | Returns the current setting. |

#### Feedback Examples

- `systemsetting get model`  
returns  
`systemsetting model "RealPresence "`

Limitations

None

Comments

None

## ***systemsetting sipaccountname***

Gets or sets the SIP user account name.

Syntax

```
systemsetting sipaccountname <"sipuser">
systemsetting get sipaccountname
```

Table 1.

| Parameter | Description                      |
|-----------|----------------------------------|
| get       | Returns the current setting.     |
| "sipuser" | Specifies the user account name. |

Feedback Examples

- `systemsetting sipaccountname polycom_user`  
returns  
`systemsetting sipaccountname polycom_user`
- `systemsetting get sipaccountname`  
returns  
`systemsetting sipaccountname polycom_user`

Limitations

None

Comments



None

## ***systemsetting sipdebug***

Gets or sets the state of SIP debug tracing in the system log.

Syntax

```
systemsetting sipdebug <True|False>
systemsetting get sipdebug
```

Table 1.

| Parameter | Description                                   |
|-----------|-----------------------------------------------|
| get       | Returns the current setting.                  |
| True      | Enables SIP debug tracing in the system log.  |
| False     | Disables SIP debug tracing in the system log. |

Feedback Examples

- `systemsetting sipdebug True`  
returns  
`systemsetting sipdebug True`
- `systemsetting get sipdebug`  
returns  
`systemsetting sipdebug True`

Limitations

None

Comments

None

## ***systemsetting sipenable***

Enables or disables SIP calling.

## Syntax

```
systemsetting sipenable <True|False>
systemsetting get sipenable
```

Table 1.

| Parameter | Description                  |
|-----------|------------------------------|
| get       | Returns the current setting. |
| True      | Enables SIP calling.         |
| False     | Disables SIP calling.        |

## Feedback Examples

- ```
systemsetting sipenable True  
returns  
systemsetting sipenable True
```
- ```
systemsetting get sipenable
returns
systemsetting sipenable True
```

## Limitations

None

## Comments

None

## ***systemsetting sipforcereuse***

Enables or disables the SIP force reuse function, which forces the proxy server to reuse the existing SIP connection for requests in the reverse direction by using the SIP port as the source port.

## Syntax

```
systemsetting get sipforcereuse
systemsetting sipforcereuse <True|False>
```

Table 1.

| Parameter | Description                            |
|-----------|----------------------------------------|
| get       | Returns the current setting.           |
| True      | Enables the SIP force reuse function.  |
| False     | Disables the SIP force reuse function. |

#### Feedback Examples

- `systemsetting get sipforcereuse`  
returns  
`systemsetting sipforcereuse True`
- `systemsetting sipforcereuse True`  
returns  
`systemsetting sipforcereuse True`
- `systemsetting sipforcereuse False`  
returns  
`systemsetting sipforcereuse False`

#### Limitations

None

#### Comments

None

### ***systemsetting sippassword***

Sets the SIP server password.

#### Syntax

```
systemsetting sippassword <"password">
```

Table 1.

| Parameter  | Description                                |
|------------|--------------------------------------------|
| "password" | Password used to register with SIP server. |

#### Feedback Examples

- ```

systemsetting sippassword secret
returns
systemsetting sippassword secret

```

Limitations

None

Comments

None

systemsetting sipproxyserver

Gets or sets the address of the SIP proxy server.

Syntax

```

systemsetting sipproxyserver <address>
systemsetting get sipproxyserver

```

Table 1.

Parameter	Description
get	Returns the current setting.
"address"	Address of the proxy server. Can be an IP address or fully qualified domain name (FQDN).

Feedback Examples

- ```

systemsetting sipproxyserver pserver.abc.com

```

```
returns
systemsetting sipproxyserver pserver.abc.com
```

- ```
systemsetting get sipproxyserver
returns
systemsetting sipproxyserver pserver.abc.com
```

Limitations

None

Comments

None

systemsetting sipregistrarserver

Gets or sets the address of the SIP registrar server.

Syntax

```
systemsetting sipregistrarserver <address>
systemsetting get sipregistrarserver
```

Table 1.

Parameter	Description
get	Returns the current setting.
“address”	Address of the registrar server. Can be an IP address or fully qualified domain name (FQDN).

Feedback Examples

- ```
systemsetting sipregistrarserver pserver.abc.com
returns
systemsetting sipregistrarserver pserver.abc.com
```
- ```
ssystemsetting get sipregistrarserver
returns
systemsetting sipregistrarserver pserver.abc.com
```

Limitations

None

Comments

None

systemsetting siptransportprotocol

Gets or sets the protocol the system uses for SIP signaling.

Syntax

```
systemsetting siptransportprotocol <Auto|TLS|TCP|UDP>  
systemsetting <get> siptransportprotocol
```

Table 1.

Parameter	Description
get	Returns the current setting.
Auto	Sets the SIP transport protocol to automatic negotiation.
TLS	Sets TLS as the SIP transport protocol. TLS provides a secure transport.
TCP	Sets TCP as the SIP transport protocol. TCP provides a reliable transport.
UDP	Sets UDP as the SIP transport protocol. UDP provides a best-effort transport.

Feedback Examples

- `systemsetting get siptransportprotocol`
returns
`systemsetting siptransportprotocol Auto`
- `systemsetting siptransportprotocol TLS`
returns

```
systemsetting siptransportprotocol TLS
```

- ```
systemsetting siptransportprotocol TCP
```

```
returns
```

```
systemsetting siptransportprotocol TCP
```
- ```
systemsetting siptransportprotocol UDP
```

```
returns
```

```
systemsetting siptransportprotocol UDP
```

Limitations

None

Comments

None

systemsetting sipusername

Gets or sets the system's SIP name.

Syntax

```
systemsetting sipusername ["name"]  
systemsetting get sipusername
```

Table 1.

Parameter	Description
get	Returns the current setting.
"name"	Specifies the SIP URI for SIP registration.

Feedback Examples

- ```
systemsetting sipusername Polycom
```

```
returns
```

```
systemsetting sipusername Polycom
```
- ```
systemsetting get sipusername
```

```
returns
```

```
systemsetting sipusername Polycom
```

Limitations

None

Comments

None

systemsetting stereoenable

Gets the current setting or specifies whether Polycom® StereoSurround™ technology is used for all calls.

Syntax

```
systemsetting stereoenable <True|False>  
systemsetting get stereoenable
```

Table 1.

Parameter	Description
get	Returns the current setting.
True	Enables Polycom StereoSurround.
False	Disables Polycom StereoSurround.

Feedback Examples

- ```
systemsetting stereoenable True
returns
systemsetting stereoenable True
```
- ```
systemsetting get stereoenable  
returns  
systemsetting stereoenable True
```

Limitations

None

Comments

None

systemsetting telnetenabled

Gets or sets the telnet ports.

Syntax

```
systemsetting telnetenabled <True|False>  
systemsetting get telnetenabled
```

Table 1.

Parameter	Description
get	Returns the current setting.
True	Enables ports 23 and 24.
False	Disables ports 23 and 24.

Feedback Examples

- `systemsetting get telnetenabled`
returns
`systemsetting get telnetenabled`
- `systemsetting telnetenabled True`
returns
`systemsetting telnetenabled True`
- `systemsetting telnetenabled`
returns
`error: command needs more parameters to execute successfully`

Limitations

None

Comments

After making a change, you must restart the system for the setting to take effect.

systemsetting transcodingenabled

Gets or specifies whether the system allows each far-site system to connect using the best possible call rate and audio/video algorithm.

Syntax

```
systemsetting transcodingenabled <True|False>  
systemsetting get transcodingenabled
```

Table 1.

Parameter	Description
get	Returns the current setting.
True	Enables transcoding.
False	Disables transcoding.

Feedback Examples

- `systemsetting transcodingenabled True`
returns
`systemsetting transcodingenabled True`
- `systemsetting get transcodingenabled`
returns
`systemsetting transcodingenabled True`

Limitations

None

Comments

None

systemsetting webenabled

Gets or specifies whether to allow remote access to the system using the web interface.

Syntax

```
systemsetting webenabled <True|False>
systemsetting get webenabled
```

Table 1.

Parameter	Description
get	Returns the current setting.
True	Enables remote access from the web interface.
False	Disables remote access from the web interface.

Feedback Examples

- ```
systemsetting webenabled True
returns
systemsetting webenabled True
```
- ```
systemsetting get webenabled
returns
systemsetting webenabled True
```

Limitations

None

Comments

You must restart the system for changes to take effect.

systemsetting whitebalancemode

Gets or sets the white balance mode for a connected Poly camera.

Syntax

```
systemsetting whitebalancemode
<Auto|Manual|2300K|2856K|3200K|3450K|3680K|4160K|4230K|4640K|5120K|5200K|5600K|6504K>
systemsetting get whitebalancemode
```

Table 1.

Parameter	Description
get	Returns the current setting.
Auto Manual 3200K 3680K 4160K 4640K 5120K 5600K	Auto - Automatic white balance. Manual - Fixed white balance (measured in Kelvin). 2300K 2856K 3200K 3450K 3680K 4160K 4230K 4640K 5120K 5200K 5600K 6504K

Feedback Examples

- `systemsetting whitebalancemode Auto`
 returns
`systemsetting whitebalancemode Auto`
- `systemsetting get whitebalancemode`
 returns
`systemsetting whitebalancemode Auto`

Limitations

None

Comments

None

Video display APIs

- [configpresentation](#)

- `configdisplay`
Gets or sets the dual display settings, including self view and content.
- `configpresentation`
Gets or sets the resolution and refresh rate for Monitor 1 or Monitor 2.
- `farnametimedisplay`
Gets or sets the dual display settings, including self view and content.
- `monitor1screensaveroutput`
Enables or disables the name that is displayed on a far site monitor.
- `monitor2screensaveroutput`
Gets the current setting or sets whether to send black video or "No Signal" to Monitor 1 when its screen saver starts.
- `monitor2screensaveroutput`
Gets the current setting or sets whether to send black video or "No Signal" to Monitor 2 when its screen saver starts.

configpresentation

Gets or sets the dual display settings, including self view and content.

Syntax

```
configpresentation [<self-view>↓content] get
configpresentation self-view <corner|full-screen>
configpresentation content <single|dual>
```

Table 1.

Parameter	Description
<code>get</code>	Returns the current dual-display settings for <code>self-view</code> or <code>content</code> .
<code>self-view</code>	Specifies settings for self view. Precedes the <code>corner</code> or <code>full-screen</code> parameter.
<code>corner</code>	Displays self view in the bottom corner of a monitor.
<code>full-screen</code>	Displays full screen Self View.

Parameter	Description
content	Specifies where content displays on the connected monitor(s). Precedes the single or dual parameter.
single	Displays content on one monitor.
dual	Displays content on both monitors.

Feedback Examples

- `configpresentation self-view get`
returns
`configpresentation self-view Corner`
- `configpresentation self-view full-screen`
returns
`configpresentation self-view full-screen`
- `configpresentation content get`
returns
`configpresentation content dual`
- `configpresentation content single`
returns
`configpresentation content single`

Limitations

None

Comments

None

configdisplay

Gets or sets the resolution and refresh rate for Monitor 1 or Monitor 2.

Syntax

```

configdisplay [<monitor1|monitor2>] get
configdisplay monitor1
<auto|50hz1920x1080p|60hz1920x1080p|25hz3840x2160p|30hz3840x2160p|50hz3840x2160p|60hz3840x2160p>
configdisplay monitor2 <off|auto|50hz1920x1080p|60hz1920x1080p>

```

Table 1.

Parameter	Description
get	Returns the current setting.
monitor1	Specifies Monitor 1.
monitor2	Specifies Monitor 2.
off	Sets Monitor 2 to off.
auto	Sets the monitor signal type to auto detection.
<refreshrateResolution>	Sets the resolution and refresh rate. For example, entering configdisplaymonitor1 60hz3840x2160p configures Monitor 1 to 3840x2160p, 60Hz.

Feedback Examples

- configdisplay get
returns
configdisplay monitor1 1920x1080p 60Hz, monitor2 1920x1080p 60Hz
- configdisplay monitor1 30hz1920x1080p
returns
configdisplay monitor1 1920x1080p 30Hz
- configdisplay monitor2 get
returns
configdisplay monitor2 1920x1080p 60Hz
- configdisplay monitor2 off
returns

```
configdisplay monitor2 off
```

Limitations

None

Comments

None

configpresentation

Gets or sets the dual display settings, including self view and content.

Syntax

```
configpresentation [<self-view>↓content] get  
configpresentation self-view <corner|full-screen>  
configpresentation content <single|dual>
```

Table 1.

Parameter	Description
get	Returns the current dual-display settings for self-view or content.
self-view	Specifies settings for self view. Precedes the corner or full-screen parameter.
corner	Displays self view in the bottom corner of a monitor.
full-screen	Displays full screen Self View.
content	Specifies where content displays on the connected monitor(s). Precedes the single or dual parameter.
single	Displays content on one monitor.

Parameter	Description
dual	Displays content on both monitors.

Feedback Examples

- `configpresentation self-view get`
returns
`configpresentation self-view Corner`
- `configpresentation self-view full-screen`
returns
`configpresentation self-view full-screen`
- `configpresentation content get`
returns
`configpresentation content dual`
- `configpresentation content single`
returns
`configpresentation content single`

Limitations

None

Comments

None

farnametimedisplay

Enables or disables the name that is displayed on a far site monitor.

Syntax

```
farnametimedisplay <get|on|off>
```

Table 1.

Parameter	Description
get	Returns the current setting.
on	Enables the name to be displayed for defined amount of time.
off	Disables the name on a far site monitor.

Feedback Examples

- `farnametimedisplay get`
returns
`farnametimedisplay on`
- `farnametimedisplay on`
returns
`farnametimedisplay on`
- `farnametimedisplay off`
returns
`farnametimedisplay off`

Limitations

None

Comments

The name will time out in 10 seconds after displayed.

monitor1screensaveroutput

Gets the current setting or sets whether to send black video or "No Signal" to Monitor 1 when its screen saver starts.

Syntax

```
monitor1screensaveroutput <get|black|no_signal>
```

Table 1.

Parameter	Description
get	Returns the current setting.
black	Sends black video to Monitor 1 when the system goes to sleep and the screen saver activates.
no_signal	Sends no signal to Monitor 1 when the system goes to sleep and the screen saver activates.

Feedback Examples

- `monitor1screensaveroutput black`
returns
`monitor1screensaveroutput black`
- `monitor1screensaveroutput no_signal`
returns
`monitor1screensaveroutput no_signal`
- `monitor1screensaveroutput get`
returns
`monitor1screensaveroutput no_signal`

Limitations

None

Comments

Setting Monitor 1 automatically sets Monitor 2 to the same setting.

See Also

See the [monitor2screensaveroutput](#) command.

monitor2screensaveroutput

Gets the current setting or sets whether to send black video or "No Signal" to Monitor 2 when its screen saver starts.

Syntax

`monitor2screensaveroutput <get|black|no_signal>`

Table 1.

Parameter	Description
get	Returns the current setting.
black	Sends black video to Monitor 2 when the system goes to sleep and the screen saver activates.
no_signal	Sends no signal to Monitor 2 when the system goes to sleep and the screen saver activates.

Feedback Examples

- `monitor2screensaveroutput black`
returns
`monitor2screensaveroutput black`
- `monitor2screensaveroutput no_signal`
returns
`monitor2screensaveroutput no_signal`
- `monitor2screensaveroutput get`
returns
`monitor2screensaveroutput no_signal`

Limitations

None

Comments

Setting Monitor 2 automatically sets Monitor 1 to the same setting.

See Also

See the [monitor1screensaveroutput](#) command.

Getting help

Poly is now a part of HP. The joining of Poly and HP paves the way for us to create the hybrid work experiences of the future. Information about Poly products has transitioned from the Poly Support site to the HP Support site.

The [Poly Documentation Library](#) is continuing to host the installation, configuration/administration, and user guides for Poly products in HTML and PDF format. In addition, the Poly Documentation Library provides Poly customers with information about the transition of Poly content from Poly Support to [HP Support](#).

The [HP Community](#) provides additional tips and solutions from other HP product users.

- [HP Inc. addresses](#)
- [Document information](#)

HP Inc. addresses

HP US

HP Inc.
1501 Page Mill Road
Palo Alto 94304, U.S.A.
650-857-1501

HP Germany

HP Deutschland GmbH
HP HQ-TRE
71025 Boeblingen, Germany

HP UK

HP Inc UK Ltd
Regulatory Enquiries, Earley West
300 Thames Valley Park Drive
Reading, RG6 1PT
United Kingdom

HP Spain

Cami de Can Graells 1-21
Bldg BCN01)
Sant Cugat del Valles
Spain, 08174
902 02 70 20

Document information

Model ID: Poly Studio G62 (PBJ-STG-62R - radio model / PBJ-STG-62N - non-radio model)

Document part number: P03707-001B

Last update: May 2024

Email us at documentation.feedback@hp.com with queries or suggestions related to this document.